

# IC693 PLC

## IC693ACC350, IC693ACC340/341

GFK-1920A  
June 2001

### Redundant Power Supply System

The IC693 Redundant Power Supply System consists of a **Baseplate** and an **Adapter**, described below.

#### Redundant Power Supply (RPS) Baseplate

The Redundant Power Supply Baseplate has slots for two standard IC693 power supplies, an attached adapter connection cable that connects to the Power Supply Adapter, status LED lights, a 24VDC user output, and status relay outputs. There are two models of RPS Baseplates, which are identical except for the length of the adapter connection cable. The IC693ACC340 has a 0.125-meter cable, and the IC693ACC341 has a 0.6-meter cable.

#### Redundant Power Supply Adapter

The Redundant Power Supply Adapter plugs into a standard IC693 PLC baseplate's power supply slot. It has a connector that mates to the RPS Baseplate's adapter connection cable. It also contains the backup battery and serial port connector for the PLC (backup battery and serial port connector are not functional on the individual power supplies).

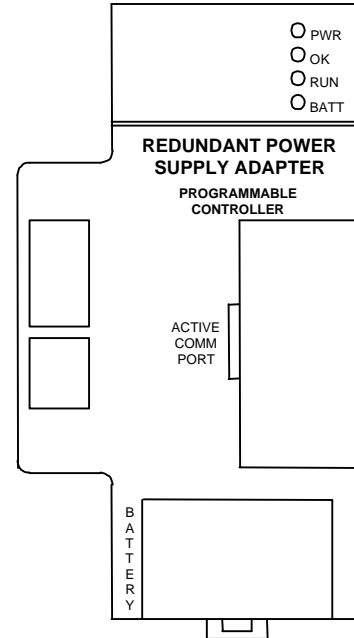

IC693ACC350 Redundant Power Supply Adapter

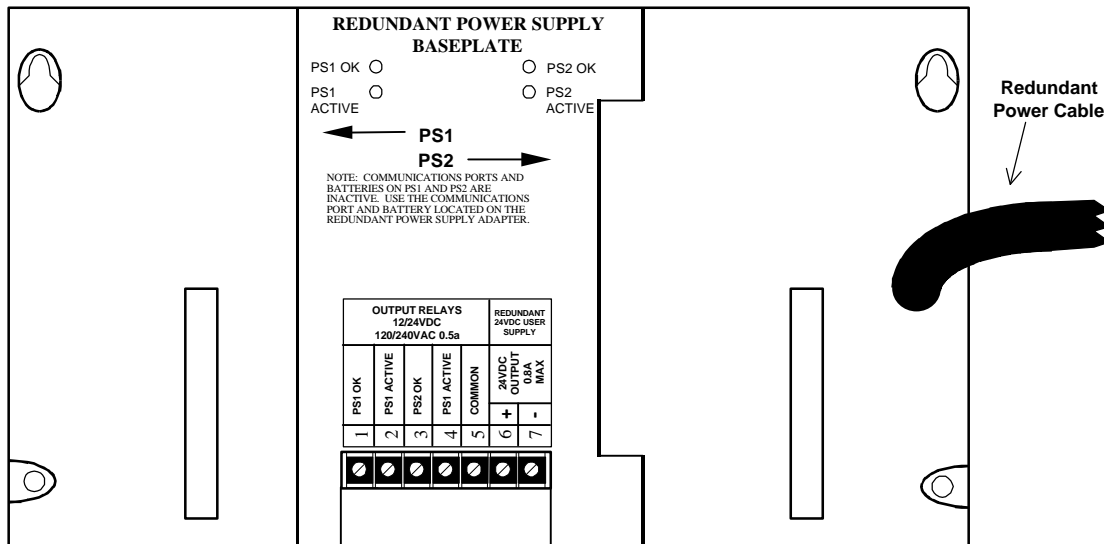

IC693ACC340/341 Redundant Power Supply Baseplate

## Redundant Power Supply Baseplate Mounting Positions

The RPS Baseplate can mount in one of three basic positions on an enclosure panel:

- Above the IC693 PLC baseplate. Use the IC693ACC341 Redundant Baseplate model (with 0.6-meter cable).
- To the left of the IC693 PLC baseplate. Use the IC693ACC340 Redundant Baseplate model (with 0.125-meter cable).
- Below the IC693 PLC baseplate. Use the IC693ACC341 Redundant Baseplate model (with 0.6-meter cable).

These three positions are illustrated below.

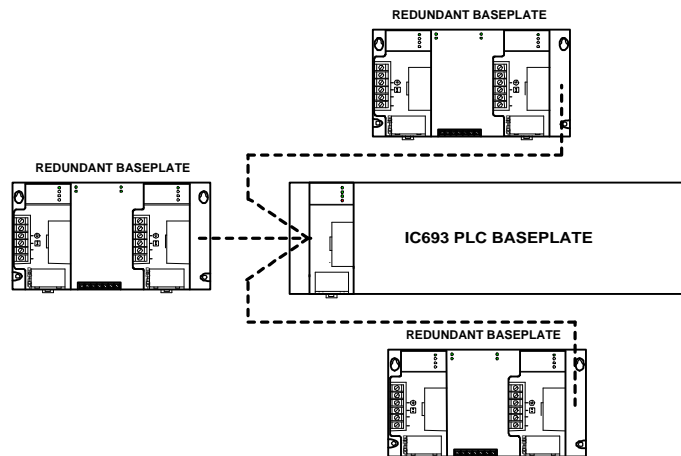

## RPS Baseplate Mounting Specifications

### Mounting Hardware

Tap four #8-32 (4mm) holes in the mounting panel using the hole spacing shown in the following figure. Use four #8-32 (4mm) machine screws with flat washers and lock washers in the baseplate mounting holes. Mounting hardware should be a high quality, corrosion-resistant type. As shown in the following figure, two baseplate holes are slotted in order to facilitate a ground wire connection (see “Grounding the RPS System” on the following page).

### Ventilation Clearance

As shown in the following figure, a minimum clearance allowance (open area) on all sides of the baseplate is required to provide adequate ventilation.

### Mounting Orientation

The baseplate is rated for full load output at 60°C (140°F) when mounted to a vertical surface and with its long dimension oriented horizontally. This orientation provides best ventilation for the power supplies. Mounting the baseplate in a different orientation results in the following load derating:

- For 25°C (77°F) temperature – full load
- For 60°C (140°F) temperature – 50% of full load

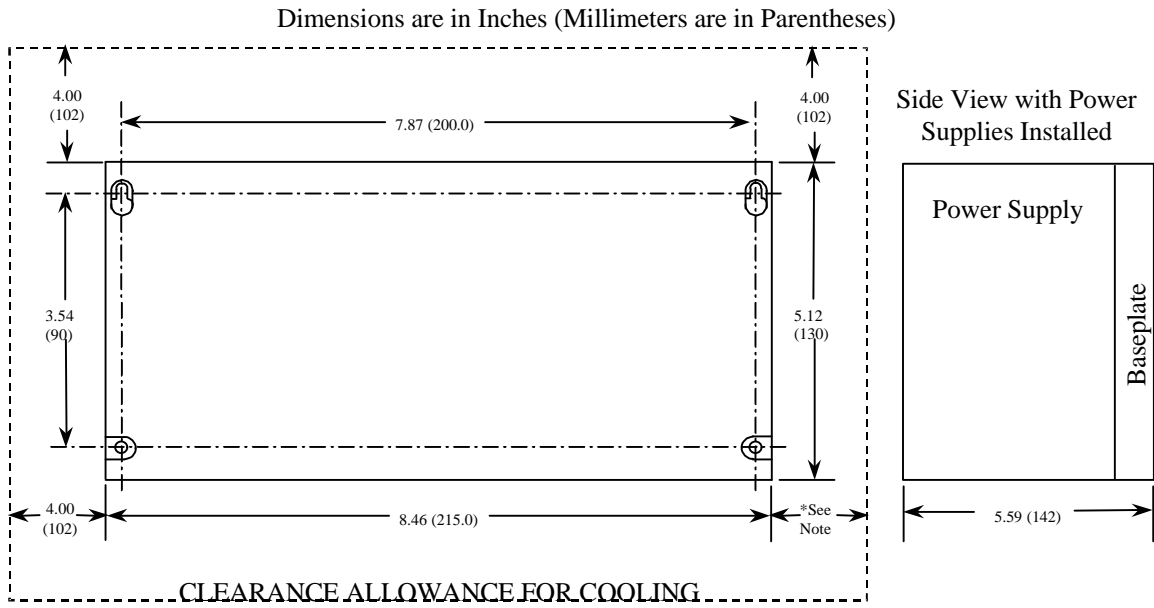

\*Note: Recommended Right Side Clearance Allowance for an IC693ACC340 is 2.5 (63) and for an IC693ACC341 is 4.00 (102)

### Grounding the RPS System

The RPS Baseplate should be grounded in the same manner as any IC693 PLC baseplate. Each ground wire should consist of a size 12 AWG or larger wire with a ring terminal crimped to each end. One end of each ground wire should be securely fastened to a conductive surface on the mounting panel (this often requires removing the paint from the panel at the spot where the ground wire is fastened). If all ground wires are connected to one point, ensure that the method (typically using a stud, nuts, and lock washers) is approved by applicable electrical codes. The next figure shows an example ground connection for each of the following components:

- RPS Baseplate and PLC Baseplate.** One end of the ground wire should be mounted under the head of the mounting bolt (with star lock washer and flat washer) in one of the baseplate’s slotted mounting holes; the other end should connect to the grounding point on the panel.
- RPS Adapter Module.** The RPS Adapter’s ground wire is supplied as part of the RPS cable. See the section “IC693ACC350 Redundant Power Supply Adapter” for details and a picture of this wire. Connect it to the grounding point on the panel.

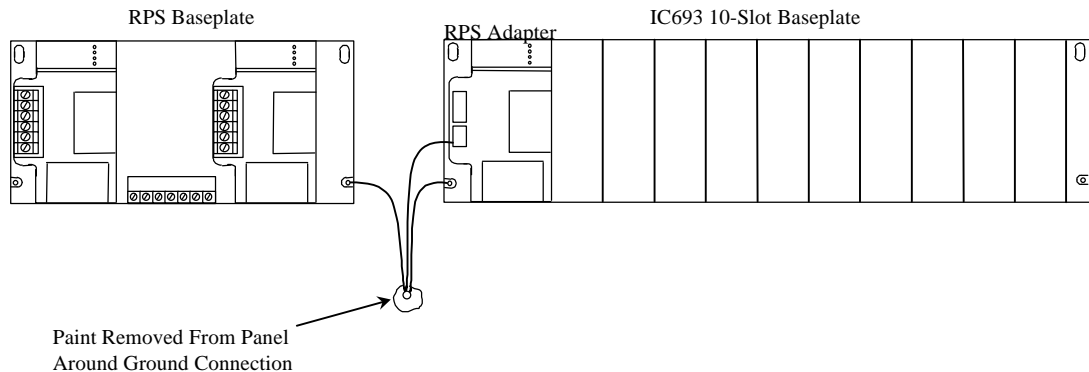

### Installing Power Supplies on the Redundant Power Supply (RPS) Baseplates

The two models of Redundant Power Supply Baseplate have mounting slots for two standard IC693 PLC power supplies. The two power supplies may be the same catalog number type or different types. They install on the RPS baseplates in the same manner as on a standard IC693 PLC baseplate. If you are not familiar with installing IC693 modules, please see the *IC693 Hardware and Installation Manual* for details. The following figure shows an RPS Baseplate with both power supplies installed.

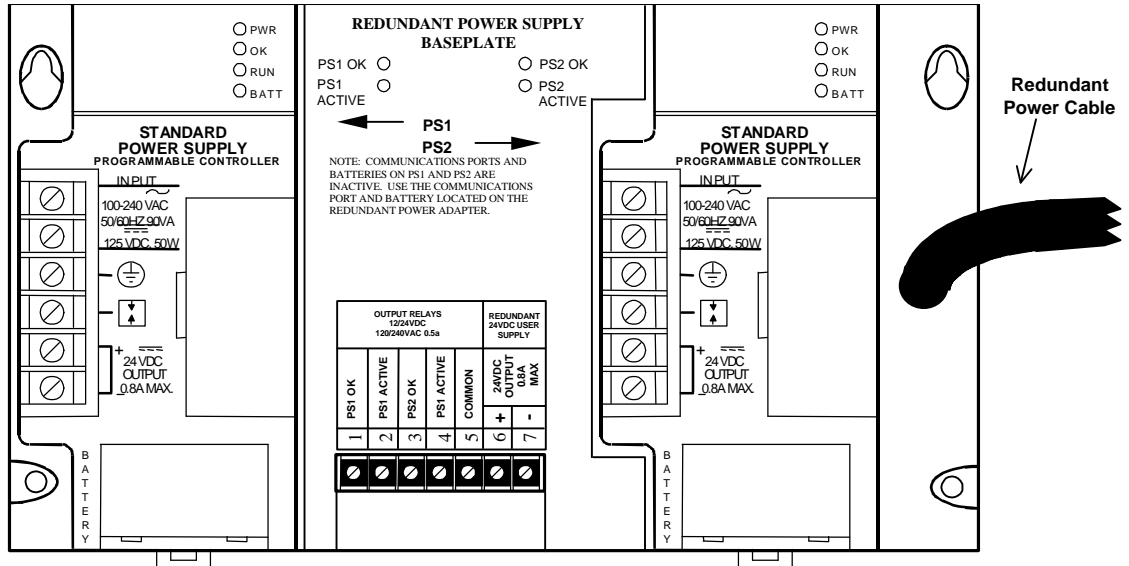

### IC693ACC350 Redundant Power Supply (RPS) Adapter

The IC693ACC350 RPS Adapter mounts in the same manner as a standard IC693 power supply in the left-most slot of an IC693 baseplate. The RPS Adapter’s physical features are shown below. The PLC LED status indicators, RAM memory backup battery, and serial port connector function in the same manner as those of a standard PLC power supply. The serial port connector and backup battery do not work on the power supplies mounted in the RPS Baseplate, and the only LED functional on those power supplies is the PWR LED. The RPS Adapter’s connectors mate to those on the RPS Baseplate’s power output cable, which splits out to two connectors at the RPS Adapter end. Also, a short ground wire is provided for grounding the RPS Adapter (see the section “Grounding the RPS System” for details).

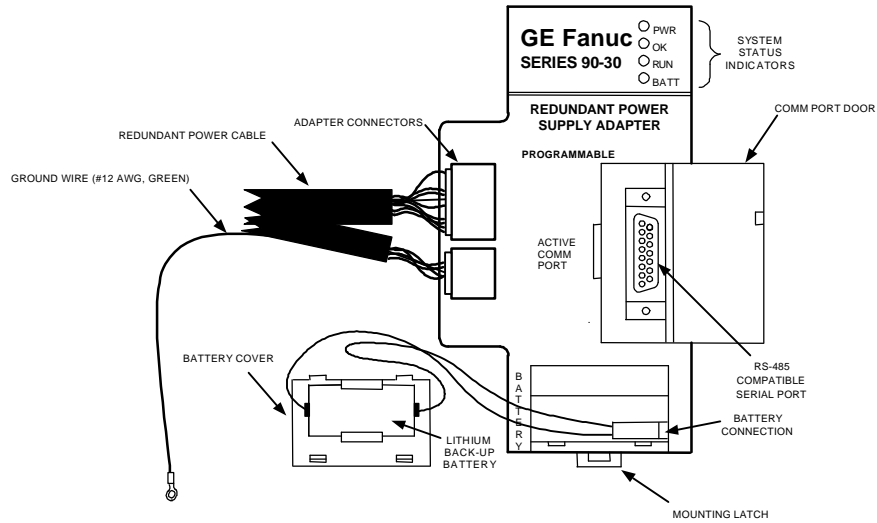

### Basic Operation

Circuitry in the RPS Baseplate arbitrates (decides which will be on-line) between the two power supplies. Power Supply 1 (PS1), on the left, is the Primary supply; Power Supply 2 (PS2), on the right, is the Secondary supply, operating in hot standby mode. Each power supply provides a discrete signal, PSOK (1 or 2), to the arbitration circuit that indicates whether the power supply is functioning correctly (logic 1 = OK, logic 0 = invalid). As long as the PSOK1 signal from PS1 stays at logic 1, it will continue to stay on-line, and PS2 will be on hot standby. However, if PS1 fails to maintain proper power output levels, its PSOK1 signal will go to logic 0 and PS2 will quickly be switched on-line. Note that the power supplies are able to hold their outputs for a short time after PSOK goes to logic zero. Later, if PS1 begins functioning correctly again, its PSOK1 signal will go to logic 1, and the arbitration circuit, after a five-second delay, will place PS1 on-line and return PS2 to a hot standby status. The five-second delay helps ensure the stability of PS1. The automatic switching by the arbitration circuit from one supply to the other is designed to be fast enough to provide uninterrupted output power to the PLC.

### Configuration

Configuration requires VersaPro 2.00 or later. Configuration consists of selecting the IC693ACC350 RPS Adapter module for the power supply slot and filling in the information on the IC693ACC350 configuration screen. See VersaPro's on-line help for details.

### Memory Backup Battery

The PLC's RAM memory backup battery must be mounted in the RPS Adapter. The standard IC693 memory backup battery, catalog number 44A724534-001 (this is not an orderable number), is used. A kit of two replacement batteries can be ordered by specifying catalog number IC693ACC301.

#### NOTE

A memory backup battery will **not be functional** if mounted in either of the RPS Baseplate's power supplies. To protect PLC memory, the backup battery **must** be mounted in the Redundant Power Supply Adapter.

## Serial Communications Port Connector

The 15-pin D-shell, serial communications port connector on the RPS Adapter provides standard PLC serial port functionality. The serial communications port connectors are **not functional** on the RPS Baseplate's power supplies.

## LED Indicator Lights

### Power Supply LED Indicator Lights

The only LED indicator light that functions on the RPS Baseplate power supplies is the PWR LED, which turns ON to indicate that its 5VDC output is valid.

### RPS Adapter LED Indicator Lights

All of the RPS Adapter's LED indicator lights function as in a normal PLC-mounted power supply. This normal operation is summarized in the following list:

- **PWR** – ON when its power supply has a correct source of power and is operating properly. This LED will be OFF if there is an input power or power supply fault.
- **OK** – ON if the PLC is operating correctly, and OFF if a problem is detected by the PLC.
- **RUN** – ON if the PLC is in the RUN mode, and OFF if the PLC is in the STOP mode.
- **BATT** – the ON state is a warning that the RAM memory backup battery is too low to maintain memory data upon loss of power. Otherwise, this LED remains OFF.

### RPS Baseplate LED Indicators

For normal operation, PS1 OK, PS1 ACTIVE, and PS2 OK should be ON, and PS2 ACTIVE should be OFF. Note that PS1 ACTIVE and PS2 ACTIVE should not be ON at the same time since only one power supply can be on-line at a time.

- **PS1 OK LED (Green)** – ON when PS1 has a correct source of power and is operating properly. This LED will be OFF if there is an input power fault or power supply fault.
- **PS1 ACTIVE LED (Green)** – ON when PS1 is on-line (supplying power to the PLC). OFF when PS1 is off-line (which means that its output is invalid).
- **PS2 OK LED (Green)** – ON when PS2 has a correct source of power and is operating properly. This LED will be OFF if there is an input power fault or power supply fault.
- **PS2 ACTIVE LED (Green)** – ON when PS2 is on-line (supplying power to the PLC). OFF when PS2 is off-line (in hot standby mode). This LED should only be ON if the PS1 output is invalid.

### RPS Relay/24VDC Output Terminal Strip

As shown in the following figures, this terminal strip provides connections for Output Relay contacts and Redundant 24VDC User Power Supply output. The picture on the left shows the terminal strip label on the RPS Baseplate. The picture on the right shows the internal connection diagram for the same terminal strip.

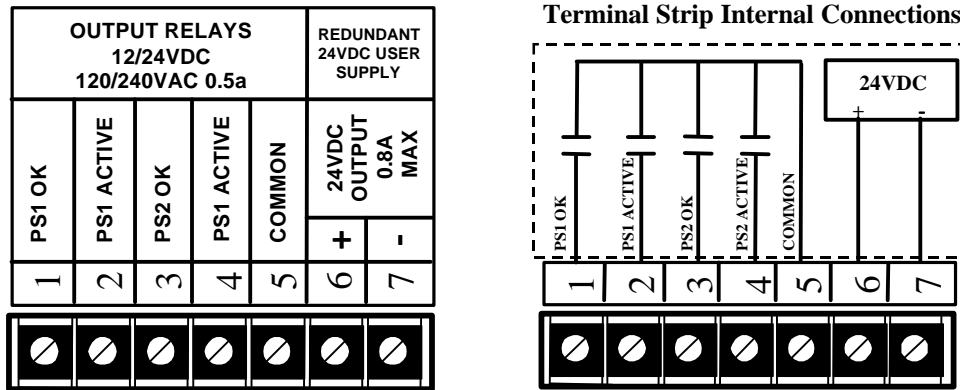

### Output Relay Terminal Connections

These four Normally Open output relay contacts reflect the conditions indicated by their corresponding LED indicator lights. If an LED, such as PS1 OK, is ON, its corresponding PS1 OK output contact will be Closed; if an LED is OFF, its corresponding output contact will be Open. These four output contacts are available on terminals 1 – 4 of the Output Relays terminal strip. All share a common terminal, labeled “COMMON,” which is terminal 5 on the Output Relays terminal strip. These contacts are rated for 12/24 VDC and 120/240 VAC at 0.5A. This terminal strip has box-style terminals that provide protection against accidental touching. Each terminal allows connection of a maximum of two stranded 14 AWG copper wires.

- **PS1 OK Contact (terminal 1)** – Closed when PS1 has a correct source of power and is operating properly. Open if there is a PS1 input power or power supply fault.
- **PS1 ACTIVE Contact (terminal 2)** – Closed when PS1 is on-line (supplying power to the PLC). Open when PS1 is off-line (which means that it is faulted).
- **PS2 OK Contact (terminal 3)** – Closed when PS2 has a correct source of power and is operating properly. Open if there is a PS2 input power or power supply fault.
- **PS2 ACTIVE Contact (terminal 4)** – Closed when PS2 is on-line (supplying power to the PLC). Open when PS2 is off-line (in hot standby mode).
- **COMMON (Terminal 5)** – One end of each of the above contacts is tied to this terminal.

### Redundant 24VDC User Supply Output

These terminals (terminals 6 and 7) provide an arbitrated, redundant, isolated 24VDC output for use by the user. Maximum output current available from this supply is 0.83 Amps. Like the other outputs from this system, this output is arbitrated from the redundant power supplies and is designed to maintain uninterrupted power even through the failure of one of the power supplies. This output voltage terminal strip has box-style terminals that provide protection against accidental touching. Each terminal allows connection of a maximum of two stranded 14 AWG copper wires.

## System Reliability and Testing

The following are some possible steps you can take to help ensure the reliability of your RPS System:

- **If applicable safety codes allow**, you might consider supplying the two power supply inputs from different power sources. For example, since you can mix power supply models in the RPS Baseplate, one could have a 120 VAC input and the other a 12 or 24 VDC input. Or, both might have 120 VAC inputs but be supplied from two different lines (read WARNING below). Note: Ensure that both power supplies can provide the necessary output current for your application; if a High Capacity power supply is required for your application, both must be High Capacity power supplies.

### WARNING

**Use of two different input power sources can create a potential hazard to personnel maintaining the system and may be subject to special electrical codes and regulations. Only qualified personnel who are trained in all applicable electrical safety standards and practices should work on this system. Failure to heed this warning could result in personal injury or death.**

- Use the RPS Baseplate's Output Contacts as inputs to a PLC or other device to monitor the condition of the RPS system. In normal operation, PS1 stays on-line, and PS2 stays in hot-standby mode. But, for example, if PS2 failed while serving in the hot standby mode, it might go unnoticed until a PS1 failure occurred, at which time the system would go down. However, by using the PS2 OK contact, the condition of PS2 can be continually monitored and problems can be reported and corrected to ensure PS2 will be ready if needed.
- If PS1 failed and PS2 came on-line automatically, the defective condition of PS1 might go unnoticed. Then, if PS2 failed, the system would go down. By using the PS1 OK contact, the condition of PS1 can be continually monitored and problems can be reported and corrected to ensure both power supplies will be ready if needed.
- If you cannot use the RPS Baseplate's Output Contacts to automatically monitor the system, make frequent visual inspections of the RPS Baseplate's LED status lights to ensure the system is functioning normally. These inspections should only be performed by trained, qualified personnel who know how to SAFELY perform this check with power applied (see previous WARNING note).
- Test the functionality of the RPS System during non-critical times (off-hours, plant shut downs, etc.) by turning off incoming power only to PS1 and observing whether PS2 comes on-line. Then, restore power to PS1 and observe whether it comes back on-line after the five-second delay. If the system fails to perform as expected, it should be repaired before the next period of critical operation begins.
- Keep spare RPS System parts on hand to help ensure that problems can be corrected promptly.
- Make a periodic visual inspection of the RPS System. During off-hours, **turn off all power** to the system and ensure that (1) baseplate ground connections are secure, (2) terminal strip connections are secure, (2) modules and connectors are seated securely, and (3) nothing is hindering the free flow of ventilation air through the power supplies.

## Environmental and Agency Requirements

Starting with catalog number suffix C, all three RPS products carry CE Marking, UL, and CUL listings/approvals (see the section "Product Release History" for details). Please see the *Product Agency Approvals, Standards, General Specifications* data sheet for environmental specifications.

Pin-Out for RPS Baseplate Cable Connectors

The following pin-out information is included for troubleshooting purposes. This information applies to the connectors on the end of the RPS Baseplate cable. **Do not unplug this connector when power is applied.** To test the voltages shown below, first **turn off power**, unplug the connector, then turn on power to the RPS baseplate power supplies.

**WARNING**

**Only qualified personnel who are trained in all applicable electrical safety standards and practices should work on this system. Failure to heed this warning could result in personal injury or death.**

- The 5V (+5 VDC) and P24V (+24 VDC Relay Power) voltages should be measured to the 0V terminals.
- The P24I Isolated +24 VDC terminal should measure +24 VDC with reference to the N24I (Isolated 24 VDC Common) terminal.
- The PSOK (Power Supply OK) signal should measure +5 VDC with reference to the 0V terminals.
- The Earth Ground terminal is capacitor-coupled to internal noise suppression components and should not be used as a reference for measuring DC voltages.

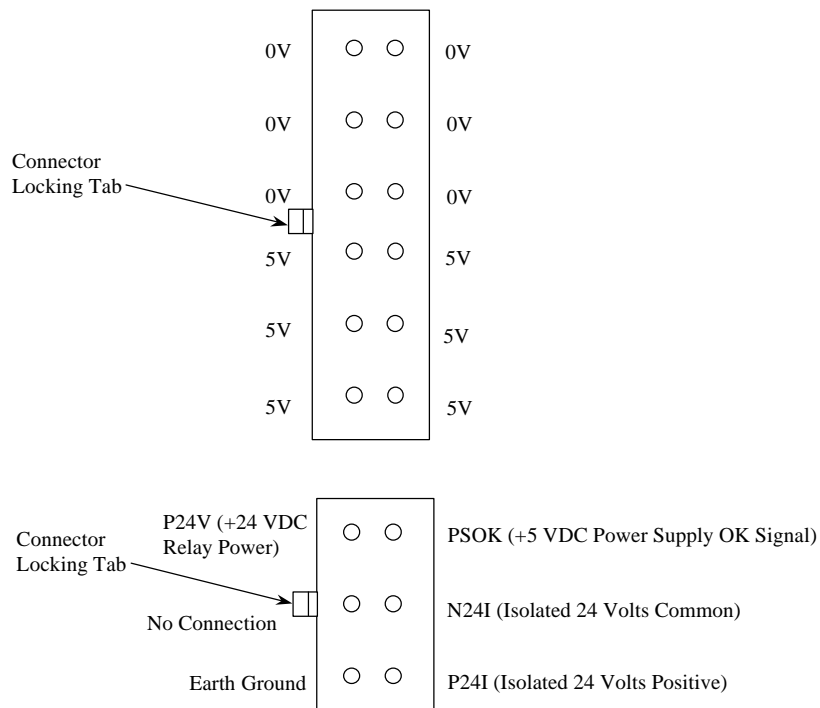

NOTE: These views are looking into the end of the cable connectors with the locking tabs on the left side as shown. Specified voltages are nominal values for a properly working system.

## Product Release History

The following table identifies the releases of this product. The letter suffix of the catalog number indicates the product release. Use the catalog numbers found on your products' labels to determine their release features.

Configuration requires VersaPro release 2.00 or later.

Catalog Number	Release Date	Data Sheet	Release Features
IC693ACC350-A IC693ACC340-A IC693ACC341-A	March 2001	GFK-1920	Initial release  UL, C-UL, and CE Marking listings or approvals were pending but not finalized
IC693ACC350-B IC693ACC340-B IC693ACC341-B	April 2001	GFK-1920	No feature changes  UL, C-UL, and CE Marking listings or approvals were pending but not finalized
IC693ACC350-C IC693ACC340-C IC693ACC341-C	June 2001	GFK-1920A	Products received UL, C-UL, and CE Marking listings or approvals