

IC660BBA026

New In Stock!

GE Fanuc

<http://www.pdfsupply.com/automation/ge-fanuc/genius-io/IC660BBA026>

Genius IO

1-919-535-3180

**In Stock! Block 24/48Vdc Analog Current Source 6 Inputs IC660B
IC660BB IC660BBA**

www.pdfsupply.com

Email: sales@pdfsupply.com

Chapter 13

Current-source Analog 6 Input Blocks

Current-source Analog Input Blocks are used to interface a controller to devices that provide 4mA to 20mA analog signal. Current-source Analog Input Blocks are available with two types of block power supply:

- 115VAC/125VDC Current-source Analog Input block (IC660BBA106)
- 24/48VDC Current-source Analog Input block (IC660BBA026).

The two blocks are the same in all other respects.

Features

A Current-source Analog Input block has six 4-to-20mA current inputs. Each input provides a 24 volt current loop power supply and is isolated from all other circuits within the block. The BSM circuitry is electrically common to Input 1, but isolated from the other inputs.

A dedicated digital output is provided to drive a Bus Switching Module when a Current-source Analog Input block is installed in a redundant bus cable system.

Additional configurable features include:

- Circuit scaling to engineering units values.
- CPU redundancy.
- Input conversion time.

Fault reporting can be enabled or disabled circuit by circuit. These blocks automatically perform the following diagnostic checks:

- Input low and high alarms
- Input overrange and underrange
- Input current below 2mA

Compatibility

Current-source Analog Input blocks require a phase B Hand-held Monitor (IC660HHM501H, version 4.5 or later) for configuration.

For a Series 90-70 PLC, the programming software must be version 3.0 or later. Genius bus controller IC697BEM731C or later is required.

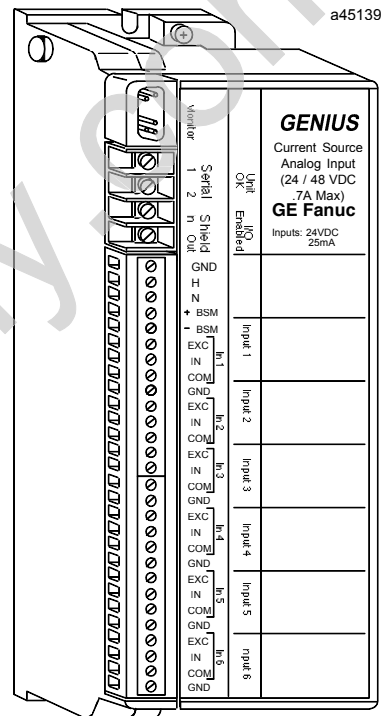

For a Series Six™ PLC, the CPU must be rev. 105 or later. For a Series Six Plus PLC, rev. 110 or later is required. The programming software must be LogiMaster™ 6 rel. 4.02 or later. These blocks are compatible with bus controllers identified by catalog numbers IC660CCBB902 and 903. They are not compatible with bus controllers IC660CBB900 and 901.

For a Series Five PLC, the CPU must be rev. 3.0 or later. The LogiMaster 5 programming software must be rel. 2.01 or later.

A Bus Switching Module must be the 24 / 48 VDC version (IC660BSM021) only.

Specifications

Block Type: Catalog Numbers: 115 VAC/125VDC Current Source Input block Terminal Assembly Only Electronics Assembly Only 24/48 VDC Current Source Input block Terminal Assembly Only Electronics Assembly Only	Six analog input circuits IC660BBA106 IC660TBA106 IC660EBA106 IC660BBA026 IC660TBA026 IC660EBA026														
Size (height x width x depth) Weight: LED's (I/O Block): BSM Control: Heat Dissipation:	.83" (22.44cm) x 3.50" (8.89cm) x 3.94" (10.00cm) 4 lbs. (1.8 kg) Unit OK, I/O Enabled 8 Switches one 24/48 VDC BSM (IC660BSM021) 12 Watts, maximum														
Block to Block Isolation: Group to Group Isolation:	1500 V for one minute 1500 V rms														
115VAC/125 VDC block power: Power supply voltage Maximum current Frequency / ripple Power supply dropout time 24/48 VDC block power: Power supply voltage Maximum current Ripple Power supply dropout time	<table> <tr> <td>115 VAC</td> <td>125 VDC</td> </tr> <tr> <td>93–132 VAC</td> <td>105–145 VDC</td> </tr> <tr> <td>250mA</td> <td>140mA</td> </tr> <tr> <td>47–63 Hz</td> <td>10% max. ripple</td> </tr> <tr> <td>1 cycle</td> <td>10 mS min.</td> </tr> </table> <table> <tr> <td>18–56 VDC</td> </tr> <tr> <td>700mA</td> </tr> <tr> <td>10% max.</td> </tr> <tr> <td>10 mS min.</td> </tr> </table>	115 VAC	125 VDC	93–132 VAC	105–145 VDC	250mA	140mA	47–63 Hz	10% max. ripple	1 cycle	10 mS min.	18–56 VDC	700mA	10% max.	10 mS min.
115 VAC	125 VDC														
93–132 VAC	105–145 VDC														
250mA	140mA														
47–63 Hz	10% max. ripple														
1 cycle	10 mS min.														
18–56 VDC															
700mA															
10% max.															
10 mS min.															
Input Signal Characteristics: Input accuracy (at 25° C) Input resolution Input conversion time Range Overrange capacity Input diagnostics Channel to channel isolation Thermal drift (from 25° C) Input Impedance: Normal Mode Rejection: Input Excitation Characteristics: Open circuit voltage Short circuit current Loop impedance	0.1% of full scale reading 1 μ A 16.6mS to 400mS (user selectable) 4mA to 20mA 0mA to 25mA Underrange, Overrange, High Alarm, Low Alarm, Open Wire 1500 volts RMS 70 PPM per ° C typical 100 ohms \pm 5% -45 dB at 50, 60 Hz 24 VDC <75mA 1000 Ω maximum (0mA to 20mA), 800 Ω maximum (20mA to 25mA)														
Environmental: Operating Temperature Storage Temperature Humidity Vibration	0°C to +60°C (+32°F to +140°F) -40 °C to +100°C (-40°F to +212°F) 5% to 95% (non-condensing) 5 – 10 Hz 0.2" (5.08mm) displacement, 10–200 Hz at 1G														

Block Operation

These blocks have six independent inputs.

Input Circuits

Input channels use voltage to frequency converters and counters to translate analog currents to a digital value. This value is converted by the block to engineering units before it is sent to the CPU. A diagram of an input circuit is shown below.

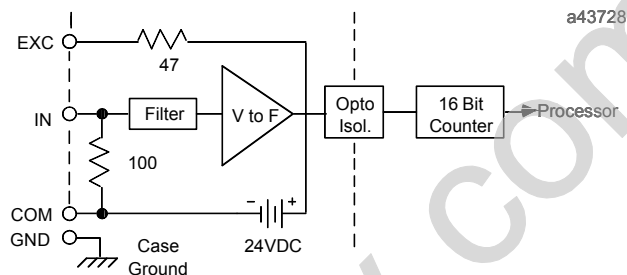

Each input circuit has a 24 volt current loop power supply, capable of providing 25mA of current. Each input is isolated from all other circuits on the block. Input accuracy is 0.1%. Input conversion time can be selected to provide the appropriate combination of noise rejection and input resolution. Conversion times are programmable from 16mS to 400mS. Resolution increases as the conversion time is lengthened. Input resolution is 1 μ A for 200mS conversion time.

Upper and lower alarm limits can be programmed for each input circuit. If either limit is exceeded, the block indicates a fault and sends a message to the Hand-held Monitor and CPU.

Input Excitation Current

The following illustration shows the input excitation current derating versus temperature. The maximum excitation current per channel is 25mA.

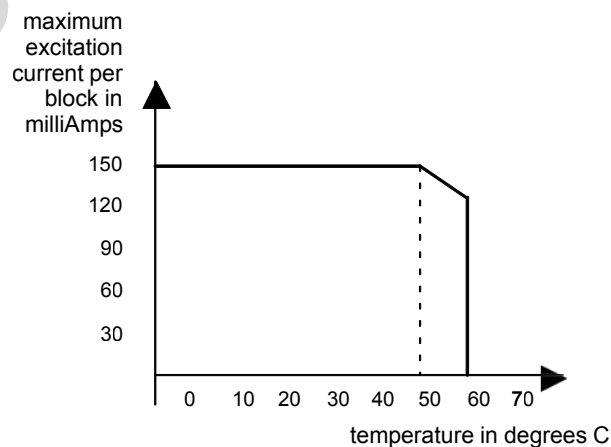

Input Data Format

Each bus scan, a Current-source Input block broadcasts 12 bytes of input data. Each input consists of 2 bytes of data in the configured units. Appendix B shows reference usage for a Series 90, Series Six, or Series Five PLC.

Byte #	Description
0	Input channel 1, bits 0 – 7
1	Input channel 1, bits 8 – 15
2	Input channel 2, bits 0 – 7
3	Input channel 2, bits 8 – 15
4	Input channel 3, bits 0 – 7
5	Input channel 3, bits 8 – 15
6	Input channel 4, bits 0 – 7
7	Input channel 4, bits 8 – 15
8	Input channel 5, bits 0 – 7
9	Input channel 5, bits 8 – 15
10	Input channel 6, bits 0 – 7
11	Input channel 6, bits 8 – 15

Hand-held Monitor Input Display

Inputs are reported as whole integers. For example, if the current value of an input was 25.36, it could be reported as:

REF	97– 120 I
I1:	253
I2:	186
>	

25	engineering units, or
253	tenths of units, or
2536	hundredths of units

Input values are displayed on the Monitor Block screen as shown at left. Individual inputs are also displayed in the Monitor/Control Reference screens.

Diagnostics

The block's advanced diagnostics provide the messages listed below. Fault messages can be cleared from the Hand-held Monitor or the CPU.

Input Open Wire: Input current is below 2mA.

Input High Alarm: Input above high alarm level.

Input Low Alarm: Input below low alarm level.

Input Overrange: Signal exceeds 25mA.

Input Underrange: Current is negative, or 0mA.

Field Wiring

Terminals 5 through 32 are used for input power, Bus Switching Module control, and field wiring devices. These terminals accept AWG #22 to AWG #14 wires. Do not overtorque the terminal screws.

The ground (GND) terminal (5) is for block safety. It is connected to the block chassis, and to terminals 13, 20, 24, 28, and 32. These terminals, which are marked GND, are for shield termination, if desired.

Power Source Wiring

For block power, connect an appropriate power source to terminals 6 and 7. For AC block power, connect the source to the H terminal and neutral to the N terminal. For DC block power, connect the source to the DC+ terminal and the return to the DC- terminal.

Self-powered or externally-powered transmitters are wired differently from those powered by the block.

Wiring for I/O Devices

Typical wiring for various configurations is shown at right. Connection of an optional Bus Switching Module is also shown.

Connecting a Bus Switching Module to a CSI Block

When a Bus Switching Module is installed, connect the BSM control wires to terminals 8 and 9. The polarity from the block is as marked; the BSM is insensitive to polarity.

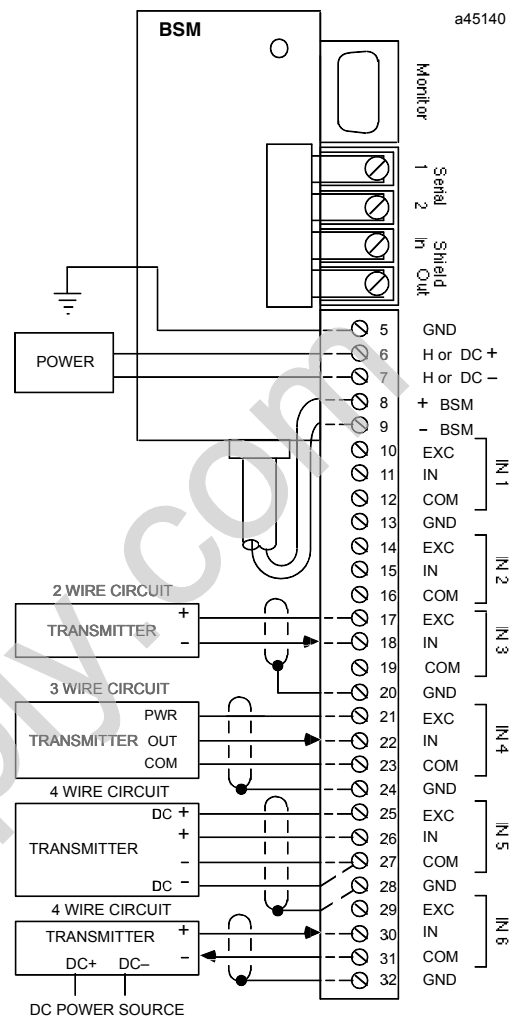

Block Configuration

The configurable features of a Current-source Analog Input Block are listed below. For many, the factory setting may not need to be changed.

Feature	Circuit or Block	Factory Setting	Selections
Device Number*	Block	null	0 to 31 (a number must be selected)
Reference Address*	Block	none	Depends on host CPU type
Baud Rate*	Block	153.6Kbstd	153.6 st, 153.6 ext, 76.8, 38.4 Kb
Configuration Protected	Block	disabled	enabled/disabled
Report Faults	Circuit	yes	yes, no
Channel active	Circuit	active	active, inactive
BSM Present	Block	no	yes, no
BSM Controller	Block	no	yes, no
Redundancy Mode	Block	none	none, standby
Input conversion time	Block	400mS	16mS to 400mS
Input Scaling	Circuit	1 μ A/eu	" 32767 eng units 0 to +25000 μ A
Low Alarm	Circuit	0	" 32767 eng. units
High Alarm	Circuit	+25000	" 32767 eng. units

Features marked with an asterisk in the table are configured from the Program Block ID screen of the Hand-held Monitor, as explained in chapter 3.

The rest of the features can be configured either using a Hand-held Monitor, or by sending a Write Configuration datagram to the block from the host.

Before configuration begins, the features of each Current-source Analog Input Block should be decided upon, then recorded on a copy of the Configuration Worksheet printed on the next page.

Current-source Analog Input Blocks Configuration Worksheet

Block _____ Location _____

Block Features:

Configuration Protected (Y/N) _____ Block Number (0-31) _____

Reference Address _____ through _____ Input Conversion Time _____ (mS)

Baud Rate (153.6 Kb Std/153.6 Kb Ext/76.8 Kb/38.4 Kb) _____

Redundancy Features:

BSM Present (Y/N) _____ BSM Controller (Y/N) _____

Redundancy Mode (none, standby) _____

Circuit Features:

	Inputs					
	1	2	3	4	5	6
References: From	_____	_____	_____	_____	_____	_____
To	_____	_____	_____	_____	_____	_____
Report Faults? (Y/N)	_____	_____	_____	_____	_____	_____
Channel Active? (Y/N)	_____	_____	_____	_____	_____	_____
Scaling Points:						
Low Pt (eng units)	_____	_____	_____	_____	_____	_____
Low Pt (μ A)	_____	_____	_____	_____	_____	_____
High Pt (eng units)	_____	_____	_____	_____	_____	_____
High Pt (μ A)	_____	_____	_____	_____	_____	_____
Low Alarm	_____	_____	_____	_____	_____	_____
High Alarm	_____	_____	_____	_____	_____	_____

Report Faults to CPU

Fault reports to the host can be disabled or enabled for any circuit.

If fault reporting is enabled, the block sends a message to the host if any fault occurs on that circuit.

If Fault reporting is disabled, the block does not send fault reports to the CPU.

Regardless of whether fault *reporting* is enabled, the block detects faults on the circuit, and takes appropriate action. If a fault occurs, the block's Unit OK LED blinks and a fault report is sent to a Hand-held Monitor. The fault condition must be corrected for proper operation of the block.

If the CPU requests diagnostic information from the block using Read Diagnostics datagrams, the block returns current diagnostics for all circuits, including those with CPU fault reporting disabled.

Hand-held Monitor Configuration Steps

```
REPORT FAULTS 97
I I I I I I
Y Y Y Y Y Y
> tgl entr nxt
```

1. Line 3 shows the current Report Faults configuration of each circuit (circuits are shown on line 2 for reference).
2. To move the cursor and select a circuit for configuration, press F1 (>).
3. To change a selection, press F2 (tgl). To save the new selection, press F3 (entr).
4. Press F4 (next) when you are ready to advance to the next configuration display.

Channel Active

If a channel is not wired, or if a channel is wired but should not report diagnostics, that channel should be configured as inactive.

The block processes input data from an inactive channel, but does not perform fault detection. The block's Unit OK LED does not indicate faults for inactive channels.

Hand-held Monitor Configuration Steps

Line 3 shows the current Channel Active configuration of each circuit (circuits are shown on line 2 for reference).

```
CHANNEL ACTIVE
I I I I I I
Y Y Y Y Y Y
> tgl entr nxt
```

1. To move the cursor and select a circuit for configuration, press F1 (>).
2. To change a selection, press F2 (tgl). To save the new selection, press F3 (entr).
3. Press F4 (next) to advance to the next configuration display.

Circuit Scaling

All circuits on the block can be scaled independently. To scale a circuit, two sets of values are entered: two engineering units values and their associated signal levels. Based on these two pairs of values, the block will be able to calculate engineering units for all other input or output levels.

The block will use the configured scaling values to convert the input signal levels (0 to " 24000 μ A) into engineering units values. Each engineering units value is an integer to " 32767. The converted number is still a numerical value, and will appear as such on the Hand-held Monitor or at the CPU with its programming device. The applicable units of measure should be recorded separately on a meter or display. Scaling can also be used to compensate for field device inaccuracies.

On a new block, the scaling is set to 1 μ A per engineering unit. If this is appropriate, it will not need to be changed.

The most accurate scaling comes from actual measurements. The process must be set to two distinctly different conditions, so two engineering units measurements can be taken. If the block is online to the process, it will automatically provide the signal level for each engineering units measurement. If the block is not online to the process, the signal level associated with each engineering units value must also be measured external to the block.

Entering Scaling Values

If you are NOT measuring the process while scaling the circuit, have the two pairs of scaling values ready. If you ARE measuring the process to scale the circuit, set the process to one of the two conditions being measured.

Hand-held Monitor Configuration Steps

```

IN 1  97- 120I
STS ENG  uA
 30636  3957
> scale  nxt

```

```

IN 1  ENG  uA
LOW 850  100
HI 30970 4000
> chng entr nxt

```

1. Line 1 shows which circuit is selected. If you want to scale another circuit, press F1 (>).
2. If you are NOT measuring the process with the block online, go to step 4. If you are measuring the process with the block online, continue at step 3.
3. Line 3 on the status screen shows an engineering units value and the equivalent μA signal level for the selected circuit. The engineering units value, on the left, is calculated from on the current scaling. If the scaling is wrong, the engineering units value is too. Make a note of the μA value shown on this screen; you will need this information to complete the next screen.
4. Press F2 (scale) to scale the circuit.
5. Line 2 shows the circuit's low pair of engineering units and μA values. All values on this screen are configured values, not measured values. Pressing F1 (>) moves the cursor between lines.
6. Enter the engineering units value(s). This must be an integer. For greater resolution, increase the configured values by a convenient multiple, such as 10 or 100. That is, to measure tenths of degrees, you would configure low and high engineering units values of 10x the actual measured temperature. Or to measure hundredths of feet per second, you would configure engineering units values of 100x the measured velocity.
7. After each entry, press F3 (entr).
8. Enter the associated μA value(s). If you are measuring the process online, enter the value read from the HHM's status screen. If you are measuring the process with the block offline, enter the signal level obtained with an external measuring device.
9. To save the new entries for a circuit, press F3 (entr) again.
10. Press F4 (next) to return to the status screen.
11. If you are using measured values, set the process to a different condition. Repeat the necessary steps above.
12. Press F4 (nxt) to return to the status screen. From the status screen, select F (>) to select another circuit for scaling.
13. When you are finished scaling circuits, press F4 (nxt) to configure additional block features.

Input Conversion Time

Input conversion time determines the length of time required to make one analog to digital conversion on each input channel. The table below shows the available conversion times and their associated resolution and line rejection capabilities. For a new block, 400mS is the default. This conversion time, which provides the maximum resolution and noise rejection, is suitable for most applications.

Change it only if faster update times are required. The following table shows the available conversion times, and the resolution and noise rejection for each.

Conversion Time (mS)	Resolution		Rejected Frequencies (Hertz)
	(μ A)	(bits)	
17	12	11+	60
20	10	11+	50, 400
33	6	12+	60
40	5	12+	50, 400
67	3	13+	60
80	2.5	13+	50, 400
100	2	14	50, 60, 400
200	1	15	50, 60, 400
400	0.5	16	50, 60, 400

Hand-held Monitor Configuration Steps

```

INPUT CONV.TIME
REF 97- 128 A
    400 mS
    tgl entr nxt
  
```

1. The screen displays the selected conversion time. If this is not appropriate, press F2 (tgl) to change it. To save the new selection, press F3 (entr).
2. Press F4 (next) to advance to the next configuration display.

Alarm Thresholds

Each input circuit can have two unique alarms, one for a low value and one for a high value. The high value should be greater than the low value. If an input reaches one of the limits, the block sends the actual value and a LOW ALARM or HIGH ALARM message. The message identifies the circuit in alarm. Only one message is sent upon reaching the threshold. Alarms do not stop the process or change the value of the input.

Alarm Thresholds are scaled values between +/-32,767 engineering units. For a new Current-source Analog Input block, the default Alarm Thresholds are 0 (low) and +25000 (high). Typically, Alarm Thresholds are set at levels beyond which the input should not operate or levels beyond which alternate processing is required.

Because Alarm Thresholds are engineering units values, if scaling is changed, Alarm Thresholds should be reviewed and adjusted if necessary. Alarm Thresholds can also be changed by the ladder logic program in the CPU. If an input reached its high alarm, a new limit could be set. This could generate a high-high alarm or an alarm-cleared threshold. Two examples are described on page 10-18.

Hand-held Monitor Configuration Steps

ALARM	97
I1 LOW I1 HI	
-32767 32767	
> chng	next

1. The screen displays the low and high Alarm Thresholds for the block's first input.
2. To select the next circuit, press F1 (>) to move the cursor from LOW to HI, then press F1 (>) again.
3. To change the threshold shown at the cursor location, press F2 (chng).
4. To save the new selection, press F3 (entr).
5. Press F4 (next) when you are ready to advance to the next configuration display.

BSM Present

If the block is connected to a single bus or to just one trunk of a dual bus, BSM Present should be set to NO. Select YES if the block is located in a cluster connected to dual busses via a Bus Switching Module.

Hand-held Monitor Configuration Steps

```
BSM PRESENT ?
REF 97- 128A
STATUS = YES
    tgl entr nxt
```

1. To change the configuration, press F2 (tgl).
2. To save the new selection, press F3 (entr).
3. Press F4 (next) to advance to the next configuration display.

BSM Controller

A BSM Controller is a block to which a Bus Switching Module is directly attached, which controls the BSM's switching action. For a new block, the default is NO. Change it only if the block will be used as a BSM Controller.

To change this configuration with a Hand-held Monitor, the block must first be configured for BSM PRESENT. The BSM CONTROLLER menu will not appear if BSM PRESENT is set to NO.

Hand-held Monitor Configuration Steps

```
BSM CONTROLLER?
REF 97- 128A
STATUS = NO
    tgl entr nxt
```

1. To change the configuration, press F2 (tgl).
2. To save the new selection, press F3 (entr).
3. Press F4 (next) to advance to the next configuration display.

CPU Redundancy

The block can be configured for No Controller redundancy or Hot Standby redundancy. For new blocks, it is set for No Controller Redundancy. It must be changed only if the block should be able to receive output data from two CPUs.

In Hot Standby mode, a block receives communications from both CPUs. The block prefers communications sent by the bus interface module (Bus Controller or PCIM) with Device Number 31. If communications from that controller are not available, the block will accept communications from Device Number 30.

Hand-held Monitor Configuration Steps

CPU REDUNDANCY
REF 97- 128A
HOT STBY MODE
tgl entr nxt

1. To change the current selection, press F2 (tgl).
2. Press F3 (entr) to save the new selection.
3. Press F4 (nxt) to advance to the next configuration display.

Configuration Protection

After the block is configured, its Configuration Protection should be enabled to prevent unwanted changes (from a Hand-held Monitor and from the CPU). Configuration Protection can only be set and removed by a Hand-held Monitor. For a new block, Configuration Protection is disabled.

Hand-held Monitor Configuration Steps

CONFIG PROTECT
REF 97- 128A
DISABLED
tgl entr nxt

1. To change the current selection, press F2 (tgl).
2. Press F3 (entr) to save the new selection.
3. Press F4 (nxt) to return to the first configuration display.