

IC660EBA101
New In Stock!
GE Fanuc

<http://www.pdfsupply.com/automation/ge-fanuc/genius-io/IC660EBA101>

Genius IO
1-919-535-3180

In Stock! Electronic Assembly for IC660E IC660EB IC660EBA

www.pdfsupply.com

Email: sales@pdfsupply.com

Specifications

Block Type: Catalog Numbers: 115 VAC/125 VDC RTD Block Terminal Assembly Only Electronics Assembly Only 24/48 VDC RTD Block Terminal Assembly Only Electronics Assembly Only	6 RTD-compatible inputs, 3 isolated groups of 2 IC660BBA101 IC660TBA101 IC660EBA101 IC660BBA021 IC660TBA021 IC660EBA021						
LEDs (I/O Block): Size (height x width x depth): Weight: Heat Dissipation:	Unit OK, I/O Enabled 8.83" (22.44cm) x 3.50" (8.89cm) x 3.94" (10.00cm) 4 lbs. (1.8 kg) 7W maximum						
Block to Block Isolation: Group to Group Isolation:	1500 V 300 V						
115 VAC/125 VDC block power: Power supply voltage: Power supply dropout time: 24/48 VDC block power: Power supply voltage: Power supply dropout time:	<table> <tr> <td>115 VAC</td> <td>125 VDC</td> </tr> <tr> <td>93–132 VAC @ 7W 47–63 Hz</td> <td>105–145 VDC @ 7W 10% max. ripple</td> </tr> <tr> <td>1 cycle</td> <td>10mS</td> </tr> </table> 18–56 VDC @ 7W, 10% max. ripple 10mS	115 VAC	125 VDC	93–132 VAC @ 7W 47–63 Hz	105–145 VDC @ 7W 10% max. ripple	1 cycle	10mS
115 VAC	125 VDC						
93–132 VAC @ 7W 47–63 Hz	105–145 VDC @ 7W 10% max. ripple						
1 cycle	10mS						
Input Characteristics: Input resolution Absolute accuracy (at 25C) Platinum or Nickel: 10Ω Copper: Input update frequency Input filter ranges (per block) RTD linearization Resistance measurement range Diagnostics	0.1 C " 0.5 C typical, " 1.0C maximum " 5C typical, " 10C maximum Once every 400 ms, 800 ms, or 1600 ms 400 ms, 800 ms, 1600 ms Platinum (DIN 43760), Nickel (DIN 43760), Copper, Linear 0 to 5000Ω Input shorted, Internal fault, Wiring error, Open wire, Overrange, Underrange, High Alarm, Low Alarm						
Environmental: Operating temperature Storage temperature Humidity Vibration	0C to +60C (32F to +140F) –40C to +100C (–40F to 212F) 5% to 95% (non-condensing) 5 – 10 Hz 0.2" (5.08mm) displacement, 10–200 Hz at 1G						

Block Operation

For each pair of inputs, a multiplexer switches the A/D converter between the RTD inputs and internal reference resistors that are used for self-calibration. The following diagram shows one pair of inputs.

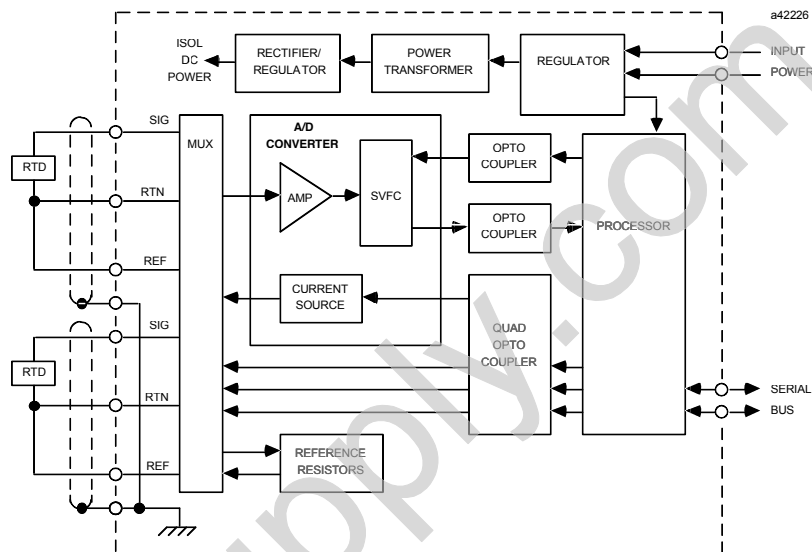

Opto-couplers isolate the control and clock signals; a small transformer isolates the circuit power. A synchronous voltage-to-frequency converter changes the measured signals to the proportional frequency sent via an opto-coupler to the processor. The processor's frequency counter converts this synchronous frequency to a 16-bit binary number.

The processor corrects each input measurement for lead resistance and for internal offset and gain drifts as it converts the input to an ohmic value. This value is either reported as is, or linearized according to the RTD type selected and converted to a value in degrees. The per channel update rate (input filter time) is preset. It may be 400, 800, or 1600 milliseconds. These selections provide 14, 15, or 16 bit resolution of the measurement.

Input Data Format

Each bus scan, an RTD block broadcasts 12 bytes of input data. Each input consists of 2 bytes of data in the configured units (C, F, ohms, or counts). Appendix B shows reference usage for a Series 90, Series Six, or Series Five PLC.

Byte #	Description
0	Input channel 1, bits 0 – 7
1	Input channel 1, bits 8 – 15
2	Input channel 2, bits 0 – 7
3	Input channel 2, bits 8 – 15
4	Input channel 3, bits 0 – 7
5	Input channel 3, bits 8 – 15
6	Input channel 4, bits 0 – 7
7	Input channel 4, bits 8 – 15
8	Input channel 5, bits 0 – 7
9	Input channel 5, bits 8 – 15
10	Input channel 6, bits 0 – 7
11	Input channel 6, bits 8 – 15

Except as noted on the next page, temperature data from an RTD block is never overwritten due to the presence of a fault condition. The data continues to change after a fault condition has been detected.

Hand-held Monitor Input Display

The Hand-held Monitor displays the configured unit values. The following example shows the Monitor Block screen with configured units of tenths of degrees C.

```

REF  97– 120 I
I1:  150.0 C
I2:  25.5 C
>

```

Diagnostics

Circuit diagnostics for RTD Input blocks are listed below. Active circuits can be configured not to send diagnostic messages to the CPU if a fault occurs. However, such circuits still respond to faults and report them to the Hand-held Monitor.

If the CPU requests diagnostic information from the block using a Read Diagnostic datagram, the block returns current diagnostics for all active circuits, including any with CPU fault reporting disabled. It will not return diagnostics from inactive circuits.

It is necessary to clear any fault that occurs to re-enable detection of that particular fault. For example, after a high alarm is reported the temperature may drop back to an acceptable level. The block continues to supply the actual temperature data. However, to re-enable high alarm detection, it is necessary to clear the existing High Alarm fault report.

Input Shorted	This diagnostic indicates an input circuit measurement below the minimum expected for RTD type. It may indicate a fault in the wiring or in the RTD. Instead of reporting the actual input value, the block uses the appropriate Underrange value (see below).
Internal Fault	An internal fault occurs if one or more of the internal auto-calibration readings for a pair of channels is out of tolerance. When this fault occurs, the block reports a value of zero for each channel of the faulty pair. The block's Electronics Assembly should be replaced.
Wiring Error	A wiring error fault occurs if connections between the RTD and the block's Terminal Assembly are incorrect. The incorrect connections may cause faulty input data to be reported. Field wiring should be changed to match the wiring diagram indicated on the block's faceplate.
Open Wire	The block reports an Open Wire diagnostic if there is less current than expected for the input type on that circuit. An Open Wire diagnostic may also mean that the input circuit excitation current is not present. The RTD may be missing or faulty, or the RTD is not connected to the block.
Overrange	The block sends an Overrange message if the Celsius or Fahrenheit input value exceeds expected maximum positive value (limits are 850C or 1562F for platinum, 250C or 482F for nickel, +3276.7C or +3276.7F otherwise). This only occurs when converting to units of temperature.
Underrange	The block sends an Underrange message if the Celsius or Fahrenheit value exceeds expected maximum negative value (limits are -200C or -328F for platinum, -60C or -76F for nickel, -3276.7C or -3276.7F otherwise).
Low Alarm/ High Alarm	Individual low and high alarm thresholds can be configured for each input. If an input reaches one of its alarm thresholds, the block reports a Low Alarm or High Alarm diagnostic. The diagnostic is triggered upon reaching the limit and will not be repeated until circuit faults are cleared.

Field Wiring

Terminals 5 through 32 are for wiring field devices. They accept AWG #22 to AWG #14 wires.

Power Source Wiring

For block power, connect an appropriate power source to terminals 6 and 7. For an AC block, connect the AC source to the HOT terminal and neutral to the NEUT terminal. For a DC block, connect the DC source to the DC+ terminal and the return to the DC- terminal.

The ground (GND) terminal (5) is for block safety. It is connected to the block chassis.

Noise Suppression

If noise spikes exceeding 4000 volts will be present in the system, additional noise suppression is needed to protect the block. This can be provided by physically separating and shielding the RTD input leads from any noise source.

Each circuit also has a SHLD terminal for shield termination, if desired. This terminal is internally connected to the block chassis and to the input power safety ground terminal.

Additional suppression can be provided by connecting three MOVs to the block; one for each pair of input points (inputs 1&2, 3&4, and 5&6 are pairs). For one point of each input pair, connect the MOV between the RTN and SHLD terminals. For example, connect:

- terminals 10 and 12 for input 1
- terminals 18 and 20 for input 3
- terminals 26 and 28 for input 5, shown below.

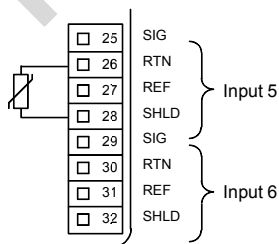

Be sure the MOV leads do not cause shorts between any other wires.

Wiring for Input Devices

There are 4 terminals available for each input device: a SIG, RTN, REF, and SHLD input. Connect RTDs between the SIG and RTN terminals.

The REF input is used for lead wire compensation of a 3-wire RTD. For a 3-wire RTD, connect the third wire to the REF terminal. For 2-wire RTDs, short the REF terminal to the RTN terminal.

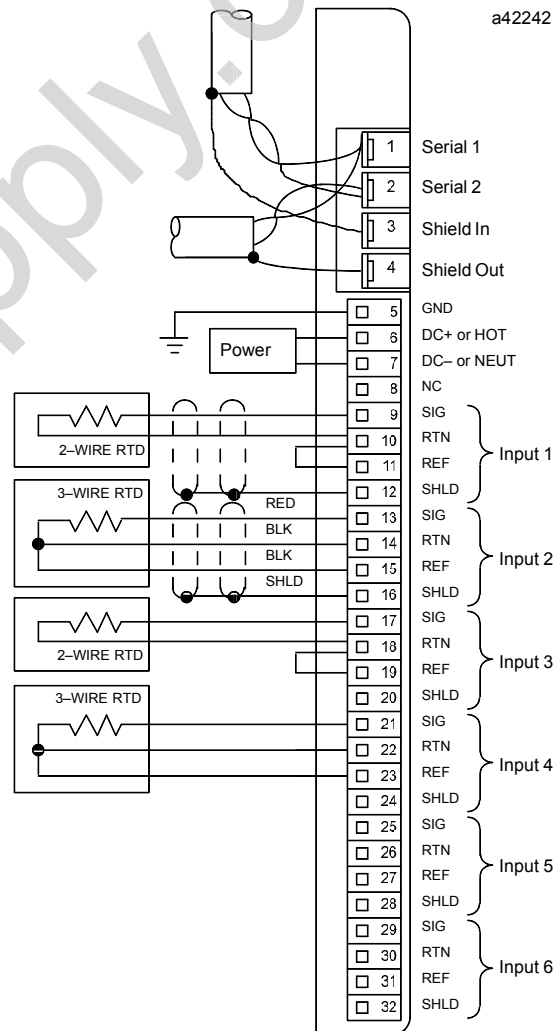

Block Configuration

The configurable features of an RTD Block are listed below. For many, the factory setting will not need to be changed.

Feature	Circuit or Block	Factory Setting	Selections
Device Number*	Block	null	0 to 31 (a number must be selected)
Reference Address*	Block	none	Depends on host CPU type
Baud Rate*	Block	153.6std	153.6 std, 153.6 ext, 76.8, 38.4 Kbd
Channel Active	Circuit	yes	yes, no
Report Faults	Circuit	yes	yes, no
Linearization	Circuit	Platinum	Platinum, Nickel, Copper, Linear
RTD Resistance	Circuit	100.0 ohms	5.0–2000.0 ohms
Alpha Type	Circuit	0.003850	0.001000–0.007000
Low Alarm	Circuit	–200C	–32,767 to +32,767 or 0 to +65,535
High Alarm	Circuit	+800C	–32,767 to +32,767 or 0 to +65,535
Input Filter Time	Block	1600mS	400, 800, 1600mS
Units	Block	Celsius	Celsius, Fahrenheit, ohms, counts

Features marked with an asterisk in the table are configured from the Program Block ID screen of the Hand-held Monitor, as explained in chapter 3.

The rest of the features can be configured either using a Hand-held Monitor, or by sending a Write Configuration datagram to the block from the host.

Before configuration begins, the block's features should be decided on and recorded on a copy of the Configuration Worksheet printed on the next page.

RTD Input Blocks Configuration Worksheet

Block _____ Location _____

Block Features:

Configuration Protected (Y/N) _____ Block Number (0-31) _____

Reference Address _____ through _____

Baud Rate (153.6 Kb Std/153.6 Kb Ext/76.8 Kb/38.4 Kb) _____

Input Filter Time (1600/800/400mS) _____

Units (tenths of degrees Celsius/tenths of degrees Fahrenheit/tenths of Ohms/counts) _____

Circuit Features:

	1	2	3	4	5	6
References: From	_____	_____	_____	_____	_____	_____
To	_____	_____	_____	_____	_____	_____
Report Faults? (Y/N)	_____	_____	_____	_____	_____	_____
Channel Active? (Y/N)	_____	_____	_____	_____	_____	_____
Linearization (PT/NI/CU/Linear)	_____	_____	_____	_____	_____	_____
RTD Resistance (5.0 –2000.0Ω)	_____	_____	_____	_____	_____	_____
Alpha (0.001000–0.07000)	_____	_____	_____	_____	_____	_____
Alarm Thresholds:						
Low (eng units)	_____	_____	_____	_____	_____	_____
High (eng units)	_____	_____	_____	_____	_____	_____

Report Faults to CPU

Fault reports to the host can be disabled or enabled for any circuit.

If fault reporting is enabled, the block sends a message to the host if any fault occurs on that circuit.

Regardless of whether fault *reporting* is enabled, the block will detect faults on the circuit, and take appropriate actions. The block's Unit OK LED will blink when a fault occurs, and a fault report will be sent to a Hand-held Monitor. The fault condition must be corrected for proper operation of the block.

If the CPU requests diagnostic information from the block using Read Diagnostics datagrams, the block returns current diagnostics for all circuits, including any with CPU fault reporting disabled.

Hand-held Monitor Configuration Steps

```
REPORT FAULT 97
I I I I I I
Y Y Y Y Y Y
> tgl entr nxt
```

1. Line 3 shows the current Report Faults configuration of each circuit (circuits are shown on line 2 for reference).
2. To move the cursor and select a circuit for configuration, press F1 (>).
3. To change a selection, press F2 (tgl). To save the new selection, press F3 (entr).
4. Press F4 (next) when you are ready to advance to the next configuration display.

Channel Active

If a channel is not wired, or if a channel is wired but should not report diagnostics, that channel should be configured as inactive.

The block processes input data from the channel, but does not perform fault detection on it. The block's Unit OK LED does not indicate faults for inactive channels.

Hand-held Monitor Configuration Steps

```
CH ACTIVE 97
I I I I I I
Y Y Y Y Y Y
> tgl entr nxt
```

1. Line 3 shows the current Channel Active configuration of each circuit (circuits are shown on line 2 for reference).
2. To move the cursor and select a circuit for configuration, press F1 (>).
3. To change a selection, press F2 (tgl). To save the new selection, press F3 (entr).
4. Press F4 (next) when you are ready to advance to the next configuration display.

Units

The block can be configured to report data as engineering units or as unconverted counts.

If units of Celsius, Fahrenheit, or ohms are selected, the block will automatically calibrate and convert input data into engineering units of:

- tenths of a degree Celsius
- tenths of a degree Fahrenheit
- tenths of ohms

Values are reported to the CPU as tenths of units. For example, 300.2 ohms is reported to the CPU as 3002. This provides greater resolution than simply reporting integer values.

The Hand-held Monitor accurately displays the engineering units value to one decimal place. The same 300.2 ohms appears on the HHM as:

300.2 Ω

If counts are selected, values are reported as they are received from the hardware, with no auto calibration performed.

Hand-held Monitor Configuration Steps

```

UNITS
REFS 97- 120A
CELSIUS
  tgl entr nxt
  
```

1. Line 3 shows the currently-selected units.
2. To change the units, press F2 (tgl). To save the new selection, press F3 (entr).
3. Press F4 (next) to advance to the next configuration display.

Linearization

The block converts the resistance from an RTD into degrees according to the type of Linearization selected for the circuit. The default Linearization type is platinum. Copper, nickel, or linear (configured for RTDs that do not conform to the DIN 43760 standard) may also be selected.

If platinum or nickel is configured, the block linearizes the input according to the DIN 43760 standard. If copper or linear is configured, the block linearizes the input using a straight line approximation based on the RTD resistance and Alpha type. If copper or linear is selected, the block converts resistance to temperature based on the entries made for RTD Resistance and Alpha, using this equation:

$$\text{Measured Temp (TC)} = \frac{(\text{RTD Resistance at TC}) - (\text{RTD Resistance at 0C})}{(\text{RTD Resistance at 0C} \times \text{Alpha})}$$

Hand-held Monitor Configuration Steps

```

LINEARIZATION
IN1 97 - 120I
PLATINUM
> tgl entr nxt

```

1. Line 3 shows the current selection for the first RTD. To change the Linearization type for the RTD currently displayed, press F2 (tgl).
2. To save the new selection, press F3 (entr).
3. To select another circuit, press F1 (>).
4. Press F4 (next) to advance to the next configuration display.

RTD Resistance

This entry specifies the nominal resistance (at 0C) in tenths of ohms of the RTD connected to each input. The default RTD Resistance depends on which type of Linearization is configured for that circuit.

Linearization Selection	Default RTD Resistance
Platinum	100.0 Ω
Nickel	100.0 Ω
Copper	10.0 Ω

RTD Resistance can be reconfigured to a value between 5.0 Ω and 2000.0 Ω . RTD Resistance specifications are available from the RTD manufacturer, or may be determined by actual measurement. RTD Resistance can also be calculated as explained on the next page. RTD Resistance must be calculated if the selection for Linearization is Linear.

Hand-held Monitor Configuration Steps

Line 3 shows the RTD Resistance for the first RTD.

```

RTD RESISTANCE
IN1 97 - 120A
OHMS= 100.0
> chng  nxt

```

1. To change the RTD Resistance type for the RTD currently displayed, press F2 (chng). From the Hand-held Monitor, RTD Resistance is entered as ohms and tenths of ohms:
92.0 Ω

When configuring the block from the CPU, RTD Resistance is entered in tenths of ohms (for this example, 920).

2. To save the new selection, press F3 (entr).
3. To select another RTD, press F1 (>).
4. Press F4 (next) when you are ready to advance to the next configuration display.

Adjusting RTD Resistance

For greater measurement accuracy, you can adjust the RTD Resistance value to produce a temperature reading that matches a known measurement point. At 100C, changing the RTD Resistance value by 0.1 ohm changes the temperature measurement by 0.37C. At 850C, changing the RTD Resistance value by 0.1 ohm changes the temperature measurement by 1.34C.

Calculating RTD Resistance

If it is necessary to calculate RTD Resistance, follow these steps.

1. Select high and low resistance values for the RTD. They should represent the span over which the RTD is expected to operate. Appropriate values should be provided in the manufacturer's documentation. If not, measure two resistance values:

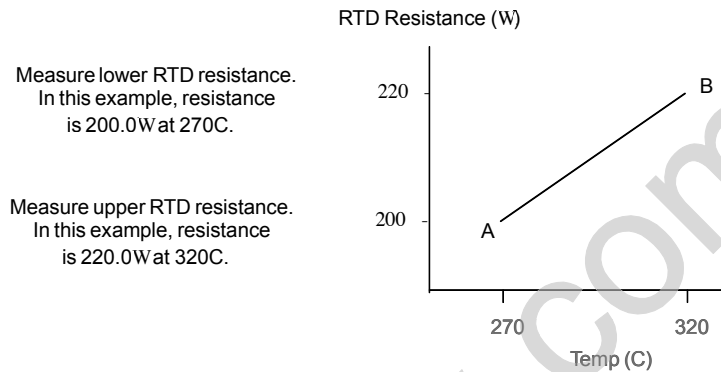

2. Calculate the slope of a straight line between the two chosen points:

$$\text{Slope} = \frac{\text{Change in Resistance}}{\text{Change in Temperature}} = \frac{220\Omega - 200\Omega}{320\text{C} - 270\text{C}} = 0.4\Omega/\text{C}$$

3. Calculate the RTD Resistance at 0C:

$$\begin{aligned} \text{RTD Resistance @ } 0^\circ &= \text{Lower Resistance} - (\text{Slope} \times \text{Lower Temperature}) \\ &= 200.0\Omega - (0.4 \Omega / ^\circ\text{C} \times 270^\circ\text{C}) = 92.0\Omega \end{aligned}$$

Alpha

This entry specifies the Alpha value of an RTD in micro-ohms/ohm-degree C. The default Alpha value depends on which type of Linearization is configured for that circuit.

Linearization Selection	Alpha Default $\Omega/\Omega C$
Platinum	0.003850
Nickel	0.006180
Copper	0.004200

The Alpha value can be reconfigured within the range of 0.0010000 to 0.007000. Alpha information is available from the RTD manufacturer. If the Alpha value is not available or if Linear was selected for Linearization, calculate Alpha as shown below.

Hand-held Monitor Configuration Steps

```

ALPHA
IN1 97— 120I
ALPHA = 0.003850
> chng      nxt

```

- Line 3 shows the Alpha value for the first RTD. The value illustrated above would be equal to $3850\mu\Omega/\Omega C$ from CPU
- To change the value currently displayed, press F2 (chng). From the Hand-held Monitor, Alpha is entered as $\Omega/\Omega C$:

0.004348

(When configuring the block from the CPU, Alpha entered in $\mu\Omega/\Omega C$ (for this example, $4348\mu\Omega/\Omega C$

- To save the new selection, press F3 (entr). To select another RTD, press F1 (>).
- Press F4 (next) when you are ready to advance to the next configuration display.

Calculating Alpha

Use this equation to calculate Alpha. If necessary, turn back to "RTD Resistance" to calculate slope.

$$\text{Alpha} = \frac{\text{Slope}}{\text{RTD Resistance at } 0C} = \frac{0.4\Omega / C}{92.0\Omega} = 0.004348\Omega/\Omega C = 4348\mu\Omega/\Omega C$$

Alarm Thresholds

Each RTD input is associated with a low alarm threshold and a high alarm threshold. If an input reaches one of its thresholds, the block sends the actual value and a LOW ALARM or HIGH ALARM message. The message identifies the circuit in alarm. Only one message is sent upon reaching the limit. Alarms do not stop the process or change the value of the input.

The default Alarm Thresholds depend on the type of Units selected:

UNITS	LOW Alarm Threshold	HIGH Alarm Threshold
Counts	0	+65,535
Ohms	0	+65,535
Celsius	-32,767	+32,767
Fahrenheit	-32,767	+32,767

Alarm thresholds can be set anywhere over the dynamic range of the signal. If alarm reporting is not wanted, the circuit's alarm thresholds can be set beyond the dynamic range of the signal so they will never be activated.

Because alarm thresholds are engineering units values, if units are changed, alarm thresholds should be reviewed and adjusted if necessary. The block will automatically switch to the default alarm thresholds when the engineering units are changed. The previous alarm limits will be saved and restored if the units selection is changed back to its previous value. If power is removed from the block, the thresholds for the currently-selected engineering units will be saved and restored when power is restored to the block.

Alarm thresholds can also be changed by the application program in the CPU. If an input reached its high alarm, a new limit could be set. This could generate a high alarm, or an alarm-cleared threshold. Two examples are described on page 10-18.

Hand-held Monitor Configuration Steps

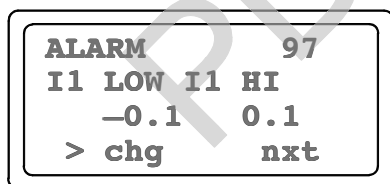

1. The screen displays the low and high alarm thresholds for the first RTD input. To select the next circuit, press F1 (>) to move the cursor from LOW to HI, then press F1 (>) again.
2. To change the threshold shown at the cursor location, press F2 (tgl).
3. To save the new selection, press F3 (entr). Press F4 (next) to advance to the next configuration display.

Input Filter Time

The Filter Time determines how frequently the block will sample new values for each input.

Filter time may be: 400mS (14-bit resolution), 800mS (15-bit resolution), or 1600mS (16-bit resolution). Longer filter times integrate input values over time to reject noise and improve resolution. The default filter time is 1600mS, which is suitable for most applications. Change it only if faster sampling is needed.

Hand-held Monitor Configuration Steps

The screen displays the selected filter time.

```

INPUT FILTR TIME
REF  97- 120A
FILTER= 400mS
      tgl entr nxt
  
```

1. If this is not appropriate, press F2 (tgl) to change it. To save the new selection, press F3 (entr).
2. Press F4 (next) to advance to the next configuration display.

Configuration Protection

After the block is configured, its Configuration Protection should be enabled to prevent unwanted changes (from a Hand-held Monitor and from the CPU). Configuration Protection can only be set and removed by a Hand-held Monitor. For a new block, Configuration Protection is disabled.

Hand-held Monitor Configuration Steps

```

CONFIG PROTECT
REF  97- 120A
DISABLED
      tgl entr nxt
  
```

1. To change the current selection, press F2 (tgl).
2. Press F3 (entr) to save the new selection.
Press F4 (next) to return to the first configuration display.