

IC660TBA105
New In Stock!
GE Fanuc

<http://www.pdfsupply.com/automation/ge-fanuc/genius-io/IC660TBA105>

Genius IO
1-919-535-3180

In Stock! Terminal Assembly for IC660BBA105 IC660T IC660TB
IC660TBA

www.pdfsupply.com

Email: sales@pdfsupply.com

Specifications

Block Type: Catalog Numbers: 115 VAC/125 VDC Current-source Analog Output block Terminal Assembly Only Electronics Assembly Only 24/48 VDC Current-source Analog Output block Terminal Assembly Only Electronics Assembly Only	6 Current-source Outputs IC660BBA105 IC660TBA105 IC660EBA105 IC660BBA025 IC666TBA025 IC666EBA025
Size, Height x Width x Depth: Weight: LED's (I/O Block): BSM Control:	8.83" (22.44cm) x 3.50" (8.89cm) x 3.94" (10.00cm) 4 lbs. (1.8 kg) Unit OK, I/O Enabled Switches one 24/48 VDC BSM (IC660BSM021)
Block to Block Isolation:	1500 V for one minute
Heat Dissipation:	12 Watts maximum
115 VAC block power: Power supply voltage Maximum current Frequency/ripple Power supply dropout time	93–132 VAC 250mA 47–63 Hz 1 cycle
125 VDC block power: Power supply voltage Maximum current Frequency/ripple Power supply dropout time	105–145 VDC 140mA 10% max. ripple 10mS min.
24/48 VDC block power: Power supply voltage Maximum current Ripple Power supply dropout time	18–56 VDC 600mA 10% max. 10mS min.
Output Signal Characteristics: Accuracy at 25 C Resolution Update frequency Range Overrange capacity Diagnostics Load Thermal drift (from 25 C)	0.15% of full-scale reading 6 μ A 25mS < 4mA to 20mA 0mA to 24mA Underrange, Overage, Feedback error 0 ohms to 850 ohms (current application) 0 to 10mA: 0 to 5-volt application 0 to 10mA: 0 to 20-volt (maximum) voltage application 35 PPM per C typical
Environmental: Operating Temperature Storage Temperature Humidity Vibration	0C to +60C (+32F to +140F) -40C to +100C (-40F to +212F) 5% to 95% (non-condensing) 5 – 10 Hz 0.2" (5.08mm) displacement, 10–200 Hz at 1G

Block Operation

The block has six independent output circuits which are electrically common to each other and the Bus Switching Module outputs, but isolated from all other circuits on the block. Power for the outputs' current loops is provided by the block.

Output Circuits

Output channels use a dual 12-bit digital to analog converter, and can independently control currents from 0mA to 24mA. A diagram of the output circuits is shown below.

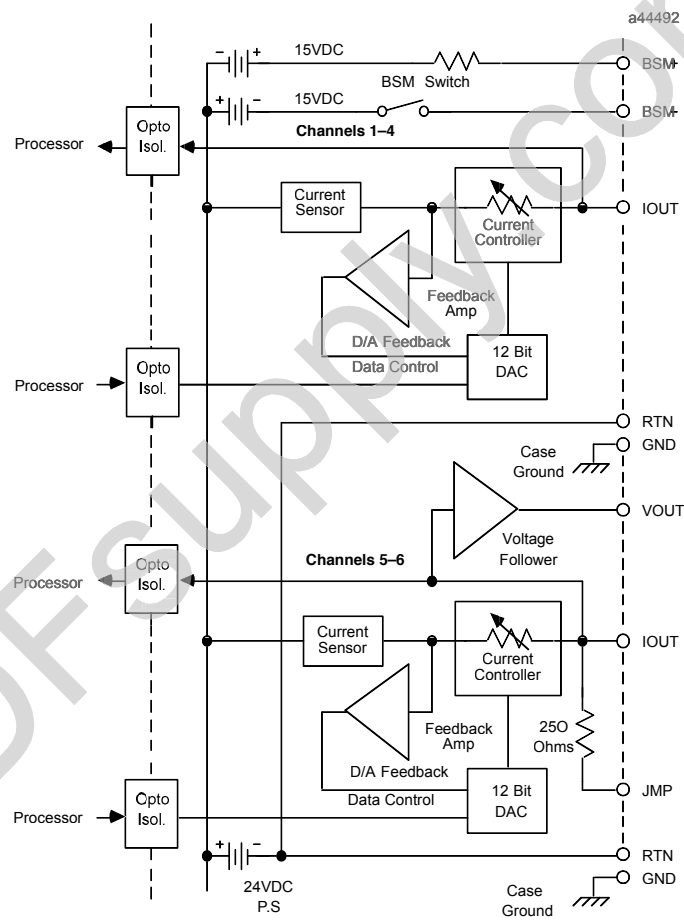

Output Data Format

A Current-source Output Block receives 12 bytes of output data each bus scan. Each analog output consists of 2 bytes of engineering units data. Appendix B shows reference usage for a Series 90, Series Six, or Series Five PLC.

Byte #	Description
0	Output channel 1, bits 0 – 7
1	Output channel 1, bits 8 – 15
2	Output channel 2, bits 0 – 7
3	Output channel 2, bits 8 – 15
4	Output channel 3, bits 0 – 7
5	Output channel 3, bits 8 – 15
6	Output channel 4, bits 0 – 7
7	Output channel 4, bits 8 – 15
8	Output channel 5, bits 0 – 7
9	Output channel 5, bits 8 – 15
10	Output channel 6, bits 0 – 7
11	Output channel 6, bits 8 – 15

The block automatically translates this engineering units value into the analog output signal used by the output device.

Hand-held Monitor Output Display

Outputs are whole integers. For example, if the current value of an output was 35.81, it could be reported as:

35	engineering units, or
358	tenths of units, or
3581	hundredths of units

Output values are displayed on the Monitor Block screen.

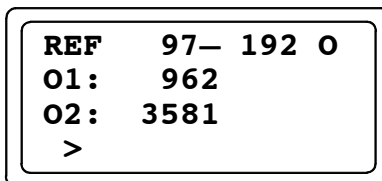

Individual outputs are also displayed in the Monitor/Control Reference screens.

Diagnostics

Current-source Analog Output Blocks perform the diagnostics described below. If a fault occurs, the block will report it to the Hand-held Monitor, and take appropriate corrective action.

Individual circuits can be configured not to send a diagnostic message to the CPU if a fault occurs. If the CPU requests diagnostic information from the block using a Read Diagnostic datagram, the block returns current diagnostics for all circuits, including any with CPU fault reporting disabled.

Output Underrange and Overrange Diagnostics

The block sends an UNDERRANGE message if conversion of the engineering units output it receives from the CPU results in a commanded output less than 0mA.

It sends an OVERRANGE message if conversion of the engineering units output it receives from the CPU results in an output signal level that exceeds 24mA. The block clamps the output to the selected range limit to protect external hardware.

Output Feedback Error

This diagnostic is used to detect wiring errors or other hardware faults on output circuits. After waiting for a configurable period of time, the block checks the current level of the output. If it is less than approximately 1.5mA, the block reports a Feedback Error. The block continues sending new values from the CPU to the output.

Feedback fault reporting should be disabled if a channel is configured for a voltage application.

Nuisance diagnostics may be reported if the Output Feedback Time selected for the circuit is too brief. If this happens, increase the feedback time or disable output feedback testing.

Field Wiring

Terminals 5 through 32 are used for input power, Bus Switching Module control, and field wiring devices. These terminals accept AWG #22 to AWG #14 wires. Do not overtorque the terminal screws.

The ground (GND) terminal (5) is for block safety. It is connected to the block chassis, and to terminals 13, 16, 19, 22, 27, and 32 which are marked GND. Each channel has one ground terminal for shield termination, if desired.

Power Source Wiring

Connect an appropriate power source to terminals 6 and 7. For AC block power, connect the source to the H terminal and neutral to the N terminal. For DC block power, connect the source to the DC+ terminal and the return to the DC- terminal.

Wiring for I/O Devices

Typical wiring for various configurations is shown.

Wiring for Voltage Outputs: If the load requires 0 to 5 volts power, connect the load across the VOUT and RTN terminals (circuits 5 and 6 only). Attach a jumper across the RTN and JMP terminals.

If the load requires a different voltage range, connect it across the VOUT and RTN terminals. Do not jumper the RTN and JMP terminals. Install an appropriate resistor across the OUT and JMP terminals. For example, the maximum voltage obtainable if a 500 ohm resistor is used is:

$$V_{MAX} = 20\text{mA} / 500\Omega = 10\text{V}$$

Wiring for Current Outputs: If the load requires current in the 4 to 20mA range, connect it between the OUT and RTN terminals (for circuits 1 through 6).

Connecting a Bus Switching Module to a CSO Block

If an optional Bus Switching Module is installed, connect the BSM control wires to terminals 9 and 10. The polarity from the block is as marked; the BSM is insensitive to polarity.

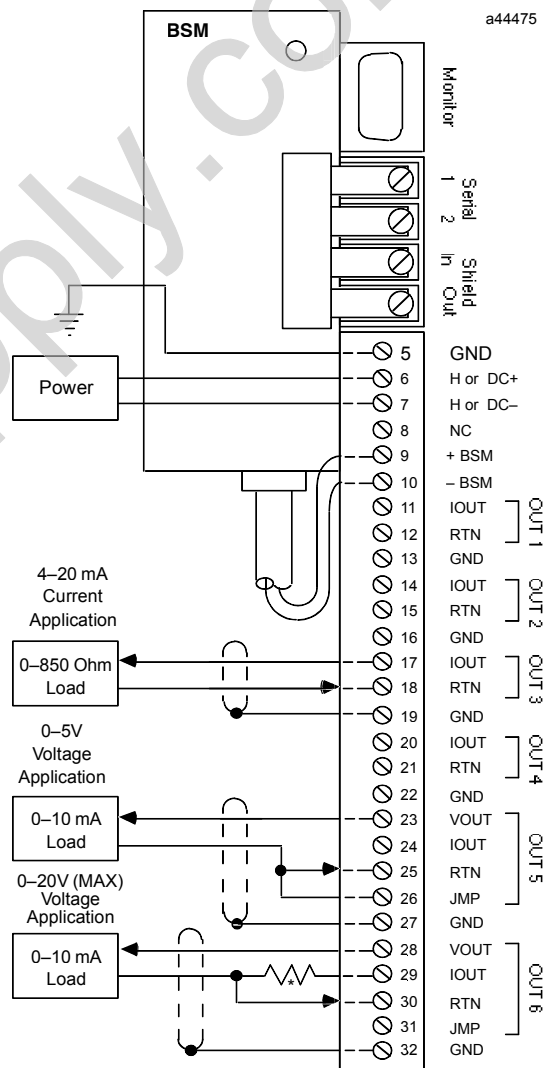

* User-Specified Resistor: 1K Ω Maximum

Block Configuration

The configurable features of a Current-source Analog Output Block are listed below. For many, the factory setting may not need to be changed.

Feature	Circuit or Block	Factory Setting	Selections
Device Number*	Block	null	0 to 31 (a number must be selected)
Reference Address*	Block	none	Depends on host CPU type
Baud Rate*	Block	153.6Kbstd	153.6 st, 153.6 ext, 76.8, 38.4 Kb
Configuration Protected	Block	disabled	enabled/disabled
Report Faults	Circuit	yes	yes, no
Channel active	Circuit	active	active, inactive
BSM Present	Block	no	yes, no
BSM Controller	Block	no	yes, no
Redundancy Mode	Block	none	none, standby
Outputs timeout	Block	3 bus scans	(for bus redundancy) 2.5 seconds or 10 seconds
Output Scaling	Circuit	1 μ A/eu	" 32767 eng units 0 to +24000 μ A
Hold Last State	Circuit	no	yes, no
Output Default	Circuit	4000	" 32767 eng. units
Output Feedback Enabled	Circuit	yes	yes, no
Output Feedback time	Circuit	0mS	0mS to 255ms

Features marked with an asterisk in the table are configured from the Program Block ID screen of the Hand-held Monitor, as explained in chapter 3.

The rest of the features can be configured either using a Hand-held Monitor, or by sending a Write Configuration datagram to the block from the host.

Before configuration begins, the features of each Current-source Analog Output Block should be decided upon, then recorded on a copy of the Configuration Worksheet printed on the next page.

Current-source Analog Output Blocks Configuration Worksheet

Block _____ Location _____

Block Features:

Configuration Protected (Y/N) _____ Block Number (0-31) _____

Reference Address _____ through _____

Baud Rate (153.6 Kb Std/153.6 Kb Ext/76.8 Kb/38.4 Kb) _____

Redundancy Features:

Redundancy Mode (None/Standby) _____ Outputs Default (2.5/10 sec) _____

BSM Present (Y/N) _____ BSM Controller (Y/N) _____

Circuit Features:

	Outputs					
	1	2	3	4	5	6
References: From	_____	_____	_____	_____	_____	_____
To	_____	_____	_____	_____	_____	_____
Report Faults? (Y/N)	_____	_____	_____	_____	_____	_____
Channel Active? (Y/N)	_____	_____	_____	_____	_____	_____
Scaling Points:						
Low Pt (eng units)	_____	_____	_____	_____	_____	_____
Low Pt (μ A)	_____	_____	_____	_____	_____	_____
High Pt (eng units)	_____	_____	_____	_____	_____	_____
High Pt (μ A)	_____	_____	_____	_____	_____	_____
Hold Last State (Y/N)	_____	_____	_____	_____	_____	_____
Default Values (eng units)	_____	_____	_____	_____	_____	_____
Output Feedback Enabled? (Y/N)	_____	_____	_____	_____	_____	_____
Output Feedback Time (0 to 255mS)	_____	_____	_____	_____	_____	_____

Report Faults to CPU

Fault reports to the host can be disabled or enabled for any circuit.

If fault reporting is enabled, the block sends a message to the host if any fault occurs on that circuit.

If Fault reporting is disabled, the block does not send fault reports to the CPU.

Regardless of whether fault *reporting* is enabled, the block detects faults on the circuit, and takes appropriate action. If a fault occurs, the block's Unit OK LED blinks and a fault report is sent to a Hand-held Monitor. The fault condition must be corrected for proper operation of the block.

If the CPU requests diagnostic information from the block using Read Diagnostics datagrams, the block returns current diagnostics for all circuits, including those with CPU fault reporting disabled.

Hand-held Monitor Configuration Steps

```
REPORT FAULTS 97
O O O O O O
Y Y Y Y Y Y
> tgl entr nxt
```

1. Line 3 shows the current Report Faults configuration of each circuit (circuits are shown on line 2 for reference).
2. To move the cursor and select a circuit for configuration, press F1 (>).
3. To change a selection, press F2 (tgl). To save the new selection, press F3 (entr).
4. Press F4 (next) when you are ready to advance to the next configuration display.

Channel Active

If a channel is not wired, or if a channel is wired but should not report diagnostics, that channel should be configured as inactive.

The block processes input data from an inactive channel, but does not perform fault detection. The block's Unit OK LED does not indicate faults for inactive channels.

Hand-held Monitor Configuration Steps

Line 3 shows the current Channel Active configuration of each circuit (circuits are shown on line 2 for reference).

```
CHANNEL ACTIVE
O O O O O O
Y Y Y Y Y Y
> tgl entr nxt
```

1. To move the cursor and select a circuit for configuration, press F1 (>).
2. To change a selection, press F2 (tgl). To save the new selection, press F3 (entr).
3. Press F4 (next) to advance to the next configuration display.

Circuit Scaling

All circuits on the block can be scaled independently. To scale a circuit, two sets of values are entered: two engineering units values and their associated signal levels. Based on these two pairs of values, the block will be able to calculate engineering units for all other input or output levels.

The block will use the configured scaling values to convert the output signal levels (0 to " 24000 μ A) into engineering units values. Each engineering units value is an integer to " 32767. The converted number is still a numerical value, and will appear as such on the Hand-held Monitor or at the CPU with its programming device. The applicable units of measure should be recorded separately on a meter or display. Scaling can also be used to compensate for field device inaccuracies.

On a new block, the scaling is set to 1 μ A per engineering unit. If this is appropriate, it will not need to be changed.

The most accurate scaling comes from actual measurements. The process must be set to two distinctly different conditions, so two engineering units measurements can be taken. If the block is online to the process, it will automatically provide the signal level for each engineering units measurement. If the block is not online to the process, the signal level associated with each engineering units value must also be measured external to the block.

Entering Scaling Values

If you are NOT measuring the process while scaling the circuit, have the two pairs of scaling values ready. If you ARE measuring the process to scale the circuit, set the process to one of the two conditions being measured.

The next configuration screen after the Channel Active screen is this status screen.

Hand-held Monitor Configuration Steps

Line 1 shows which circuit is selected.

```

OUT 1 97- 120I
STS ENG  uA
 30636 3957
> scale  nxt

```

```

OUT1 ENG  uA
LOW  850  100
HI 30970 4000
> chng entr nxt

```

1. If you want to scale another circuit, press F1 (>).
2. continue at step 3.
3. Line 3 on the status screen shows an engineering units value and the equivalent μ A signal level for the selected circuit. The engineering units value, on the left, is calculated from on the current scaling. If the scaling is wrong, the engineering units value is too. Make a note of the μ A value shown on this screen; you will need this information to complete the next screen.
4. Press F2 (scale) to scale the circuit.
5. Line 2 shows the circuit's low pair of engineering units and μ A values. All values on this screen are configured values, not measured values. Pressing F1 (>) moves the cursor between lines.
6. Enter the engineering units value(s). This must be an integer. For greater resolution, increase the configured values by a

convenient multiple, such as 10 or 100. That is, to measure tenths of degrees, you would configure low and high engineering units values of 10x the actual measured temperature. Or to measure hundredths of feet per second, you would configure engineering units values of 100x the measured velocity.

7. After each entry, press F3 (entr).
8. Enter the associated μA value(s). If you are measuring the process online, enter the value read from the HHM's status screen. If you are measuring the process with the block offline, enter the signal level obtained with an external measuring device.
9. To save the new entries for a circuit, press F3 (entr) again.
10. Press F4 (next) to return to the status screen.
11. If you are using measured values, set the process to a different condition. Repeat the necessary steps above.
12. Press F4 (nxt) to return to the status screen. From the status screen, select F2 (scale) to select another circuit for scaling.
13. When you are finished scaling circuits, press F4 (nxt) to configure additional block features.

Output Feedback Testing

After the Feedback Time (see below) period has elapsed, the block compares feedback from each output to its output value received from the CPU. If the feedback is less than 1.5mA, the block reports a Feedback Error for the circuit. For a new block, feedback testing is enabled for all outputs. It can be disabled for any or all.

Hand-held Monitor Configuration Steps

Line 3 shows the current Output Feedback configuration of the outputs (circuit types are shown on line 2 for reference).

```

FEEDBACK
O O O O O O
Y Y Y Y Y Y
> tgl entr nxt

```

1. To move the cursor and select a circuit for configuration, press F1 (>).
2. To change a selection, press F2 (tgl).
3. To save the new selection, press F3 (entr).
4. Press F4 (next) when you are ready to advance to the next configuration display.

Feedback Time

Feedback Time is the interval between the time the block receives an output value from the CPU, and the time the output channel is expected to attain the commanded value. This interval is used in conjunction with Feedback Testing, enabled or disabled above. A suitable interval should be selected so that the output current will reach its commanded value before the comparison is made. This prevents false Feedback Error diagnostics for the output. A longer feedback interval should be specified for outputs that respond slowly to changes in output signal levels.

Hand-held Monitor Configuration Steps

Line 3 shows the Feedback Time configured for the output circuit indicated on line 2.

```

FEEDBACK TIME 97
OUT1 97- 112 A
xxx mS
> chng nxt

```

1. To select the other output, press F1 (>).
2. To change the Feedback Time for the output, press F2 (chng), then enter a new time.
3. To save the new time, press F3 (entr).
4. Press F4 (next) when you are ready to advance to the next configuration display.

Hold Last State

Each output can be independently configured to either hold its last value or go to its powerup default value if the block loses CPU communications for at least 3 bus scans.

For a new block, Hold Last State is disabled for all outputs. With Hold Last State disabled, the block sets an the output to its powerup default if CPU communications are lost.

If Hold Last State is enabled, the block continues to hold the output at its current value instead of setting it to the powerup default.

Outputs remain in their last value or default indefinitely or until one of the following occurs:

- Communications with the CPU are restored.
- The Hand-held Monitor changes the output by forcing it.
- Power is removed from the block.

Hand-held Monitor Configuration Steps

```

HOLD LAST ST 97
O O O O O O
N N N N N N
> tgl entr nxt

```

1. The screen displays the current Hold Last State configuration of all outputs. On this screen,
 - Y = hold last state.
 - N = go to default state (configured on the next HHM screen)
2. To select a circuit, press F1 (>).
3. To change the selection for a circuit, press F2 (tgl). To save the new selection, press F3 (entr). Press F4 (next) to advance to the next configuration display.

Output Default Value

Outputs always go to their default values when the block is first powered up. For a new block, the output default value is 4000.

If Hold Last State was NOT enabled, the block will also default the output if CPU communications are lost. On a non-redundant system, this occurs approximately 250mS after the third bus scan passes with no CPU communications. If the block is on a redundant bus downstream of a Bus Switching Module, additional time is needed to accommodate switching of the BSM (see "Output Default Time" on page 12-15).

Hand-held Monitor Configuration Steps

```

OUTPUT DEFAULT
OUT1 97- 1200
DEFAULT:    0
> chng     nxt

```

1. The screen first displays the default value of the block's first output. To select an output, press F1 (>).
2. To change a default value, press F2 (chng), then enter the new value.
3. To save the new default, press F3 (entr). Press F4 (next) when you are ready to advance to the next configuration display.

BSM Present

If the block is connected to a single bus or to just one trunk of a dual bus, BSM Present should be set to NO.

Select YES if the block is located in a cluster connected to dual busses via a Bus Switching Module.

Hand-held Monitor Configuration Steps

```
BSM PRESENT ?  
REF 97- 128A  
STATUS = YES  
  tgl entr nxt
```

1. To change the configuration, press F2 (tgl).
2. To save the new selection, press F3 (entr).
3. Press F4 (next) to advance to the next configuration display.

BSM Controller

A BSM Controller is a block to which a Bus Switching Module is directly attached, which controls the BSM's switching action. For a new block, the default is NO. Change it only if the block will be used as a BSM Controller.

To change this configuration with a Hand-held Monitor, the block must first be configured for BSM PRESENT. The BSM CONTROLLER menu will not appear if BSM PRESENT is set to NO.

Hand-held Monitor Configuration Steps

```
BSM CONTROLLER?  
REF 97- 128A  
STATUS = NO  
  tgl entr nxt
```

1. To change the configuration, press F2 (tgl).
2. To save the new selection, press F3 (entr).
3. Press F4 (next) to advance to the next configuration display.

Output Default Time

When a Bus Switching Module is used, the Output Default Time must be long enough to allow the BSM to switch without causing outputs to default. Therefore, when BSM Present is selected (above), the block automatically changes its Output Default Time from 3 bus scans to 2.5 seconds.

If Hold Last State was selected, the block will hold outputs at their last value while the BSM switches, instead of defaulting, so there is no need to change this selection.

If Hold Last State was set to NO for any of the outputs and total bus scan time will exceed 100mS, change this selection to 10 seconds.

Hand-held Monitor Configuration Steps

```

OUTPUT DEF.TIME
REF 97- 128A
TIME = 2.5 SECS
tgl entr nxt

```

1. To change the configuration, press F2 (tgl).
2. To save the new selection, press F3 (entr).
3. Press F4 (next) to advance to the next configuration display.

CPU Redundancy

The block can be configured for No Controller redundancy or Hot Standby redundancy. For new blocks, it is set for No Controller Redundancy. It must be changed only if the block should be able to receive output data from two CPUs.

In Hot Standby mode, a block receives output data from both CPUs but uses the data from only one of them to drive its outputs. The block prefers outputs sent by the bus controller with Device Number 31. If those outputs are not available, the block will use outputs from the bus controller with Device Number 30. If no outputs from a CPU are available, the outputs either Hold Last State or go to their predefined Output Default state.

Hand-held Monitor Configuration Steps

```

CPU REDUNDANCY
REF 97- 128A
HOT STBY MODE
tgl entr nxt

```

1. To change the current selection, press F2 (tgl).
2. F3 (entr) to save the new selection.
3. Press F4 (next) to advance to the next configuration display.

Configuration Protection

After the block is configured, its Configuration Protection should be enabled to prevent unwanted changes (from a Hand-held Monitor and from the CPU). Configuration Protection can only be set and removed by a Hand-held Monitor. For a new block, Configuration Protection is disabled.

Hand-held Monitor Configuration Steps

```
CONFIG PROTECT
REF 97- 128A
DISABLED
  tgl entr nxt
```

1. To change the current selection, press F2 (tgl).
2. Press F3 (entr) to save the new selection.
3. Press F4 (next) to return to the first configuration display.