

IC660TBD120
New In Stock!
GE Fanuc

<http://www.pdfsupply.com/automation/ge-fanuc/genius-io/IC660TBD120>

Genius IO
1-919-535-3180

In Stock! Terminal Assembly for IC660T IC660TB IC660TBR

www.pdfsupply.com

Email: sales@pdfsupply.com

Warnings, Cautions, and Notes as Used in this Publication

Warning

Warning notices are used in this publication to emphasize that hazardous voltages, currents, temperatures, or other conditions that could cause personal injury exist in this equipment or may be associated with its use.

In situations where inattention could cause either personal injury or damage to equipment, a Warning notice is used.

Caution

Caution notices are used where equipment might be damaged if care is not taken.

Note

Notes merely call attention to information that is especially significant to understanding and operating the equipment.

This document is based on information available at the time of its publication. While efforts have been made to be accurate, the information contained herein does not purport to cover all details or variations in hardware or software, nor to provide for every possible contingency in connection with installation, operation, or maintenance. Features may be described herein which are not present in all hardware and software systems. GE Fanuc Automation assumes no obligation of notice to holders of this document with respect to changes subsequently made.

GE Fanuc Automation makes no representation or warranty, expressed, implied, or statutory with respect to, and assumes no responsibility for the accuracy, completeness, sufficiency, or usefulness of the information contained herein. No warranties of merchantability or fitness for purpose shall apply.

The following are trademarks of GE Fanuc Automation North America, Inc.

Alam Master	CIMSTAR	Helpmate	PROMACRO	Series Six
CIMPLICITY	Genet	Logicmaster	Series One	Series 90
CIMPLICITY 90-ADS	Genius	Modelmaster	Series Three	VuMaster
CIMPLICITYPowerTRAC	Genius PowerTRAC	ProLoop	Series Five	Workmaster

This book provides information needed to install and use a Genius I/O High Speed Counter block.

Content of this Manual

This book contains the following 6 chapters and 2 appendixes.

Chapter 1. Introduction: provides an overview of High-speed Counter block features. Chapter 1 also explains how to locate information in the rest of the book.

Chapter 2. Installation: explains installation and field wiring for the block.

Chapter 3. Configuration: describes the configurable features of the High-speed Counter, and explains configuration steps.

Chapter 4. Monitoring Operation of the High-speed Counter: shows how to use a Hand-held Monitor to display information about the block, and force or unforce its outputs.

Chapter 5. CPU Interface: provides descriptions of data that is routinely transferred between a High-speed Counter and a CPU. Chapter 5 also summarizes programming information.

Chapter 6. Programmed Communications: contains Datagram information for programmed messages between the CPU and a High-speed Counter.

Appendix A. Typical Applications: describes many application uses for a High-speed Counter block.

Appendix B. Oscillator Frequencies: lists all frequencies that can be configured for the block's oscillator output.

Changes in this Manual Revision

This version of the Genius I/O High Speed Counter User's Manual has been converted to a new Technical Publications system. There have been no changes in the technical information included in this manual, however, the format has been updated to improve readability.

Related Publications

Series 90-70 Bus Controller User's Manual (GFK-0398). Reference manual for the bus controller, which interfaces a Genius bus to a Series 90-70 PLC. This book describes the installation and operation of the bus controller. It also contains the programming information needed to interface Genius I/O devices to a Series 90-70 PLC.

Logicmaster 90-70 User's Manual (GFK-0263). Reference manual for system operators and others using the Logicmaster 90-70 software to program, configure, monitor, or control a Series 90-70 PLC and/or a remote drop.

Preface

Genius I/O System User's Manual (GEK-90486). Two-volume reference manual for system designers, programmers, and others involved in integrating Genius I/O products in a PLC or host computer environment. Volume 1 provides a system overview, and describes the types of systems that can be created using Genius products. Datagrams, Global Data, and data formats are defined in Volume 1. Volume 2 contains detailed descriptions, specifications, installation instructions, and configuration instructions for all currently-available discrete and analog blocks.

PCIM User's Manual (GFK-0074). Reference manual for the Personal Computer Interface Module, which interfaces a Genius bus to a suitable host computer. This book describes the installation and operation of the PCIM. It also contains the programming information needed to interface Genius I/O devices to a host computer.

Series Six Bus Controller User's Manual (GFK-0171). Reference manual for the bus controller, which interfaces a Genius bus to a Series Six PLC. This book describes the installation and operation of the bus controller. It also contains the programming information needed to interface Genius I/O devices to a Series Six PLC.

Series Five Bus Controller User's Manual (GFK-0248). Reference manual for the bus controller, which interfaces a Genius bus to a Series Five PLC. This book describes the installation and operation of the bus controller. It also contains the programming information needed to interface Genius I/O devices to a Series Five PLC.

At GE Fanuc Automation, we strive to produce quality technical documentation. After you have used this manual, please take a few moments to complete and return the Reader's Comment Card located on the next page.

Libby Allen
Technical Writer

Chapter 1	Introduction	1-1
	The High-Speed Counter Block	1-1
	High-Speed Counter Block Specifications	1-2
	Compatibility	1-3
	Block Operation	1-3
	Block Inputs	1-4
	Block Outputs	1-5
	High-speed Counter Block I/O Data	1-7
	Basic Counter Operation	1-8
	Type A Counter Operation	1-9
	Type B Counter Operation	1-12
	Type C Counter Operation	1-17
	Configuration	1-24
	Temporary Configuration Changes	1-25
	Monitoring/Controlling Operation of the Block	1-26
 Chapter 2	 Installation	 2-1
	Mounting the Block	2-1
	Block Wiring	2-3
	Output Power Connections	2-7
	Field Wiring Connections	2-8
	Terminal Assignments: Type A	2-9
	Terminal Assignments: Type B	2-11
	Terminal Assignments: Type C	2-13

Chapter 3	Configuration	3-1
	Required Features	3-1
	Other Configurable Features	3-2
	Configuration Steps	3-3
	Baud Rate	3-7
	Pulse Test	3-8
	Enable Outputs at Powerup	3-8
	Oscillator Frequency	3-9
	Control Inputs Threshold	3-10
	Counter Inputs Threshold	3-10
	Strobe Linkage (Counter Type B Only)	3-11
	Select Counter	3-12
	Report Faults	3-12
	Strobe Edge	3-13
	Strobe Mode (Latched Strobes)	3-13
	Strobe Effect (Counter Type A Only)	3-14
	Input Filters	3-15
	Counter Direction	3-16
	Counter Signal Mode	3-17
	Continuous or Single-Shot Counting	3-18
	Counter Timebase	3-19
	Count Limits	3-20
	Output Presets	3-21
	Home Position	3-23
	Preload Accumulator Value	3-24
	CPU Redundancy	3-25
	Configuration Protection	3-25
Chapter 4	Monitoring Operation of the High-Speed Counter	4-1
	Using the Hand-Held Monitor	4-1
	Select the High-Speed Counter	4-2
	Display Preset Output States	4-3
	Display Control Input States	4-4
	Display Current Values	4-6
	Display/Clear Output Faults	4-8
	Display/Force Output States	4-9
	Force or Unforce Outputs	4-10

Chapter 5	Input and Output Data	5-1
	Overview	5-1
	How the Host Handles High-speed Counter Inputs and Outputs	5-3
	Series 90-70 PLC	5-3
	Series Six PLC	5-4
	Series Five PLC	5-6
	Host Computer	5-6
	I/O Data: Block Configured as Type A	5-7
	I/O Data: Block Configured as Type B	5-11
	I/O Data: Block Configured as Type C	5-14
 Chapter 6	 Programmed Communications	 6-1
	Datagrams Supported by the High-Speed Counter	6-1
	Configuration Data Formats for the High-speed Counter	6-2
	Diagnostics Data Formats for the High-speed Counter	6-7
	Write Data/Read Data/Read Data Reply Datagrams	6-8
	Write Data	6-10
 Appendix A	 Typical Applications	 A-1
	Monitoring and Controlling Differential Speeds	A-2
	Direction-Dependent Positioning	A-3
	Count Doubling	A-5
	Count Doubling for a Single Pulse Stream	A-5
	Count Doubling for Quadrature-type Inputs	A-6
	Counter Cascading	A-7
	Measuring or Comparing Pulse Rates	A-8
	Measuring Pulse Time	A-10
	RPM Indicator	A-13
	Tolerance Checking	A-14
	Measuring Total Material Length	A-15
	Material-handling Conveyor Control	A-16
	Timing Pulse Generation	A-17
	Digital Velocity Control	A-19
	Dynamic Counter Preloading	A-20
	Carousel Tracking	A-21
 Appendix B	 Oscillator Frequencies	 B-1

Chapter 1

Introduction

The High-Speed Counter Block

The Genius I/O High-speed Counter block is a self-contained, configurable I/O module which provides direct processing of rapid pulse signals up to 200kHz.

Typical applications include:

- Turbine flowmeter
- Meter proving
- Velocity measurement
- Material handling
- Motion control
- Process control

The block may be powered by 115VAC and/or 10 to 30VDC. If the main power supply to the block is 115 VAC, a 10 VDC-30 VDC power source can be used as a backup. Both 115 VAC and DC power may be supplied simultaneously; if the 115 VAC source fails, the block will continue to operate on the DC backup power. Any DC source that can provide an output in the range of 10 VDC to 30 VDC can be used. The source must meet the specifications listed in this chapter. With both AC and DC power applied, block power will be taken from the AC input as long as the DC voltage is less than 20 volts.

The block provides 1, 2, or 4 counters of various complexity. If block has its own communications capability and microprocessor. It can count and provide outputs without the need to communicate with a CPU.

The block has four control outputs. It also provides a +5 volt DC output, and a square wave oscillator output that can be used as a timing reference.

The block's two topmost LEDs indicate the status of the block and the status of communications with the CPU. Four smaller LEDs indicate the on/off status of each output.

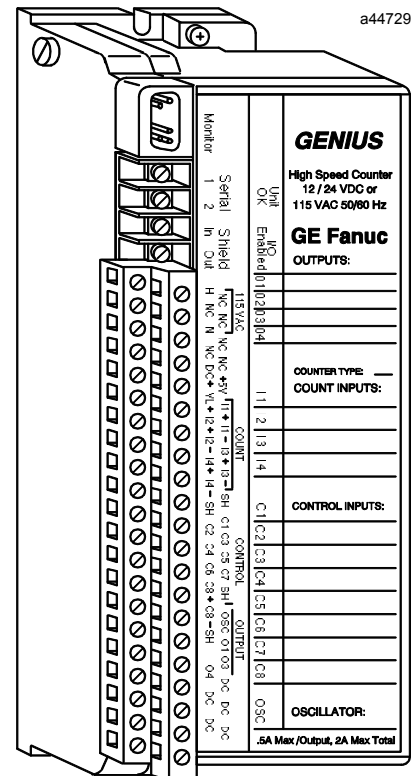

a44729

High-Speed Counter Block Specifications

GENERAL	
Dimensions	8.83" h. X 3.56" w. X 4.42" d. 22.44cm h. X 9.05cm w. X 11.22cm d.
Operating temperature	0° C to 60° C (32° F to 140° F)
Storage temperature	-40 ° C to 100° C (-40° F to 212° F)
Humidity	5% to 95% (non-condensing)
Operating voltage (one of two sources)	<u>93V to 132V AC</u> [or] <u>10V to 30V DC</u>
Frequency/ripple	47 Hz to 63 Hz 10% maximum
Required AC power	60 mA typical 250 mA typical
Required DC power	200mA typical/300mA max. @12 volts
DC power supply dropout time	10mS at 12 volts/75mS at 24 volts
AC power supply dropout time	1 cycle
LEDs (block)	Unit OK, I/O Enabled
LEDs (circuit)	Output status: logic side (four)
INPUTS	
Input voltage relative to DC- terminals	
VL+ (load voltage)	5V DC to 30V DC
Input ON:	
TTL single-ended	Vin ≥ 2.0V (sourcing 1mA min)
non-TTL single-ended	Vin ≥ 7.2V (sourcing 1.75mA min)
TTL-differential	Vin+ ≥ 0.85V (sourcing 1mA min)
non-TTL-differential	Vin+ ≥ 4.1V (sourcing 1mA min)
Input OFF:	
TTL single-ended	Vin < 0.8V
non-TTL single-ended	Vin < 6.0V
TTL-differential	Vin+ < 0.50V
non-TTL-differential	Vin+ < 4.1V
Input impedance (typical)	4.0Kohms
Selectable input filter times	High (2.5µS) or low (12.5mS) frequency
Input pulse width	
high-frequency filter selected	2.5µS minimum
low-frequency filter selected	12.5mS minimum
Count rate:	
high-frequency filter selected	200 kHz maximum
low-frequency filter selected	40 Hz maximum
OUTPUTS	
+5V	4.75V DC to 5.25V DC at 200mA
Steady state output (01 - 04) current	0.5 amps maximum per output
OSC (oscillator output)	3.8V at 4.0mA
Maximum inrush current	3 Amps per output for up to 10mS
Maximum circuit overcurrent threshold	4 amps
Block steady state output current	2 amps maximum
Output OFF leakage current	10µA (max)
Maximum switching frequency	once/second (high inrush current)
Count Input to Output delay (max)	1mS plus input filter time
Output voltage drop	2.0 volts maximum at 4 amps inrush 0.25 volt maximum at 0.5 Amp

Ordering Information

High-speed Counter block	IC660BBD120
Terminal Assembly only	IC660TBD120
Electronics Assembly only	IC660EBD120
High-speed Counter datasheet	GFK-0367

Compatibility

This block can be used with any version Series Five PLC Bus Controller (IC655BEM510), or PCIM (IC660ELB906). For the Series Six PLC, Bus Controller version IC660CBB902G or IC660CBB903G or later is required for blocks assigned to I/O references, to assure data coherence. For blocks assigned to register memory, earlier versions of IC660CBB902 and 903 can be used. Bus Controllers CBB900 and 901 cannot be used with a High-speed Counter.

A Hand-held Monitor version 3.5 (IC660HHM501D) or later is required to perform configuration and block monitoring functions. To use all features of High-speed Counter block version 120D or later, HHM version 4.0 (HHM501G) or later is required. For earlier HHM versions, an upgrade kit (44A286347-G05) can be ordered.

Block Operation

The High-speed Counter accepts twelve input signals, and can provide four output signals, plus an oscillator output and a +5 volt DC output.

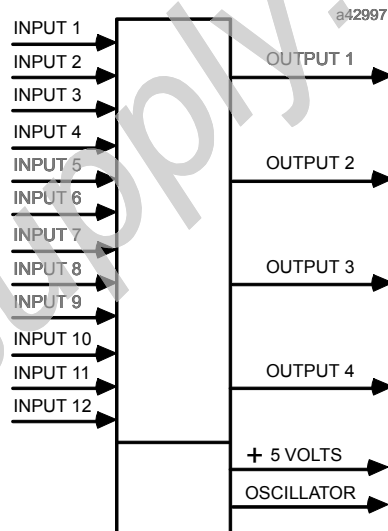

The block can have 4 counters, 2 counters, or 1 counter. Selection is made when the block is configured.

- Type A configuration –has 4 identical, independent counters
- Type B configuration –has 2 identical, independent more complex counters
- Type C configuration –has 1 complex counter.

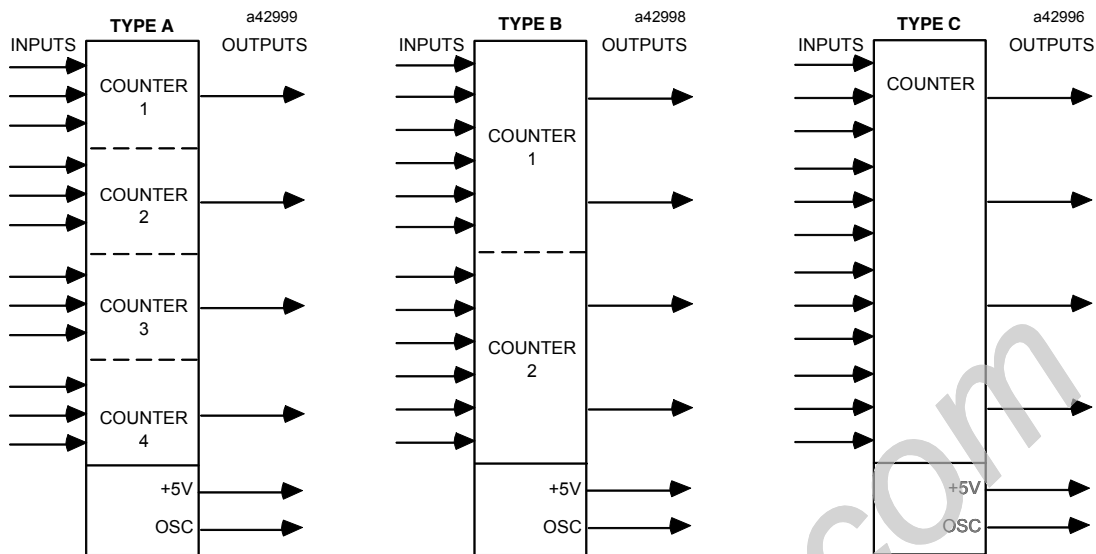

Block Inputs

The block accepts up to four differential counter inputs, and up to eight control inputs.

Counter Inputs

The four differential counter inputs (I1+ through I4-) correspond to terminals 16 through 23 on the block. Depending on the block's configured type, these inputs may be used for:

- Pulse signals
- Direction signals
- A quad B signals

The counter inputs can be assigned to either TTL or non-TTL voltage levels independently of the control inputs.

Control Inputs

The eight control inputs, designated C1 through C8-, correspond to block terminals 26 through 33 and terminal 35. Only C8 is differential; C1-C7 are single-ended. Depending on the block's configured type, these inputs can be used for:

- Preload Inputs
- Strobe Inputs
- Disable Input
- Home input
- Marker input

Control inputs can also be assigned to use either TTL or non-TTL level signals.

BlockOutputs

The block provides four counter outputs, plus an oscillator output, and a +5 volt output.

CounterOutputs

The block's four counter outputs can be used to drive indicating lights, solenoids, relays, and other devices. Short circuits and surges of short duration are tolerated. Each output circuit provides built-in protection against power surges caused by wiring errors.

The commanded state of each output is shown by an individual LED on the block.

Output Presets

The block's outputs can be programmed to turn on or off when the accumulated count reaches appropriate values. Each counter output has two Preset points, ON and OFF. The output state indicates when the counter Accumulator value lies between the defined points. For example:

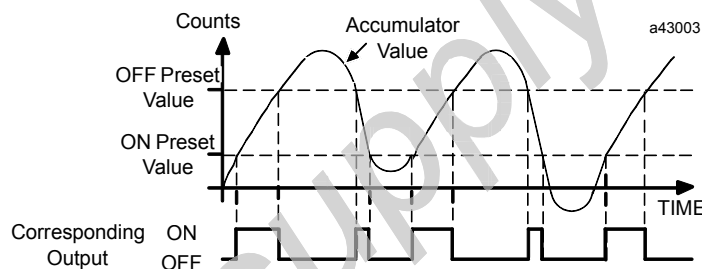

The output polarity may be configured to be either on or off between points by the relative location of the ON/OFF Presets as shown below.

Preset closest to low limit

ON
OFF

Output ON

$> =$ ON Preset
 $< =$ OFF Preset
 $<$ OFF Preset
 $>$ ON Preset

Output OFF

$>$ OFF Preset
 $<$ ON Preset
 $< =$ ON Preset
 $> =$ OFF Preset

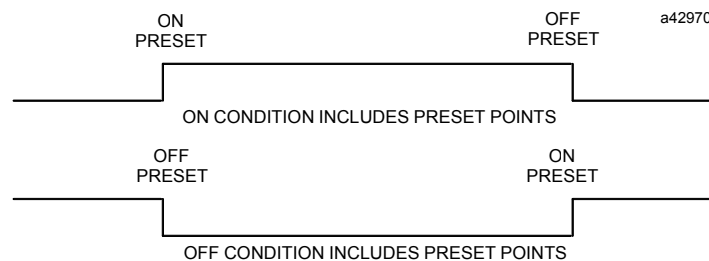

Input/Output Cycle Time

The count input-to-output delay is 1mS maximum (200µS minimum) plus the configured Input Filter Time.

Forcing Outputs

Outputs may be forced on or off, and forces may be removed, using the Hand-held Monitor. Outputs can also be forced and unforced from the CPU application program (using Force I/O and Unforce I/O datagrams). This is useful during installation and checkout.

Short Circuit Protection for Outputs

Each output circuit contains built-in protection that allows short-time surges but protects the output driver during short-circuit conditions. If an output is commanded to turn on and the current through the switch exceeds 4 amps for a period of 1 millisecond, the block automatically shuts off the switch and generates a FAILED SWITCH diagnostic.

The switch cannot be turned on again unless the fault is cleared. An output can be reset by cycling power to the block, or by sending a clear fault command to the output.

Caution

Short circuit protection protects the block if loads are 4 amps or more. Each output on the block can source a maximum of 0.5 amps. Safe operating for switching of loads between 0.5 amps and 3 amps is shown below.

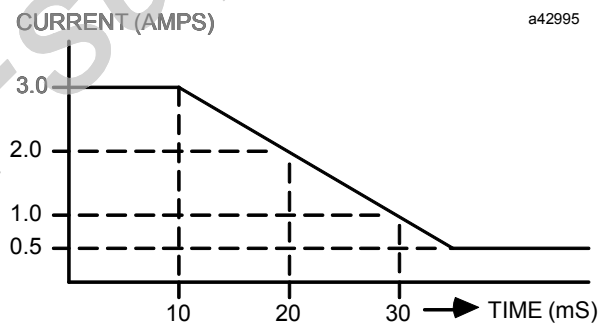

+5 Volt DC Output

The block's +5 volt output delivers 4.75 to 5.25 volts at 200mA. This source can be used to power the output loads and/or any other load that does not exceed 200mA.

Oscillator Output

The block's square wave oscillator output can be used as a timing reference for measurement. The output oscillates at a selectable frequency up to 200kHz. Appendix A shows applications for this output.

High-speed Counter Block I/O Data

The previous pages described hardware inputs to the block (such as pulse signals, direction signals, and strobe inputs), and hardware outputs from the block that can be used to drive devices such as indicating lights and relays.

For most Genius I/O blocks, such hardware inputs and outputs would correspond to the input and output data exchanged by the block and its host PLC or computer. However, for a High-speed Counter block, that is not the case.

For a High-speed Counter, input data consists of 16 words that inform the host about the operation of the block:

- Status bits:
 - Strobe status
 - Preload status
 - Output status
 - Module Ready status
 - Error status
- Accumulator values
- Strobe register values
- Counts per Timebase values

Chapter 5 shows the format of this data.

In return, during each bus scan, the host's bus controller sends the High-speed Counter block 1 word of output data. This data consists of command bits that can be used to control block operations:

- Strobe reset bits
- Preload reset bits
- Outputs enable/disable bits
- Home command (for Type C counter)
- Clear error command (for Type C counter)

Basic Counter Operation

As already noted, a block can be configured for three different types of operation. Type A, Type B, and Type C block operation are described on the following pages.

While the Type B and Type C configurations are more complex, the basic operation of all three types is similar. This illustration shows a Type A counter, the simplest type.

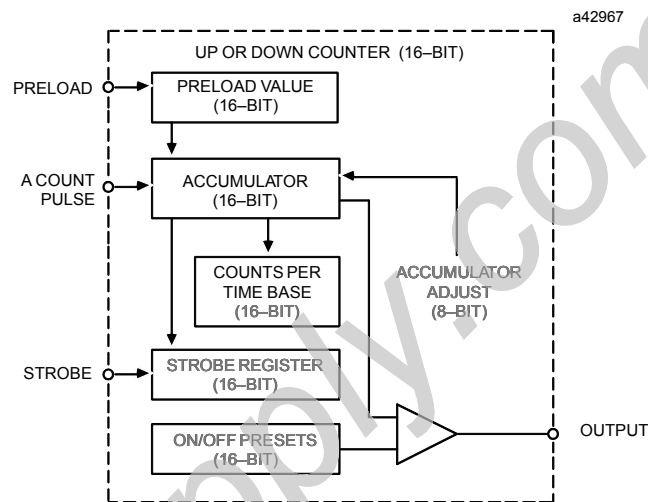

Inputs to the Block

The block stores the count total in a memory area within the block called the **Accumulator**. During operation, the block increments or decrements the total count value in the Accumulator each time it receives a count input pulse.

Counting starts (or restarts) at whatever value is appropriate for the application. This value **Preload Value** is assigned to the counter during its configuration. The block loads the Preload Value into the Accumulator in response to the corresponding **Preload Input**. It then sets the corresponding **Preload status bit** (not shown in this diagram).

If the block receives a **Strobe input** for the counter, it copies the current total count value from the Accumulator into the corresponding **Strobe register**. It then sets the corresponding **Strobe status bit**, also not shown in the diagram.

The block also stores the count rate in its **Counts per Timebase** register. The timebase for the counter is selected when the counter is configured.

Input Data the Block Sends to the Host

Like other Genius devices, the High-speed Counter block maintains regular communications with its host over the Genius bus. Once each bus scan, the block transmits the current values from its **Accumulator** and **Strobe registers**, as well as the current count rate from its **Counts per Timebase** register. Altogether, the block sends a total of 16 words (256 bits) of input data each bus scan. The

last (16th) word consists of **Status bits**. These include the **Strobe status bit** and **Preload status bit** mentioned above, plus other status bits that inform the host about the current operations of the block.

Output Data the Host Sends to the Block

The host should monitor the status bits. It can reset status bits by setting corresponding output bits that are included in the 1-word (16-bit) message it sends back to the block each bus scan. As part of this message, it can also enable or disable any or all of the block's outputs.

The host can also communicate with the block using datagram messages. Among their other uses, datagrams can read diagnostics information, read or change the block's configured parameters, and adjust the count value in the Accumulator by sending an adjustment value to the Accumulator Adjust register.

Outputs from the Block

The counter's output (or multiple outputs, for Type B or C) are set up (again, by configuration), to go either on or off when the Accumulator count value reaches a selected level.

The block's configuration can be used to either enable or disable outputs when the block is started up. If outputs are disabled at startup, then can then be enabled by the host using its regular output data message to the block.

Type A Counter Operation

If "Type A" is selected during block configuration, the block has four 16-bit counters.

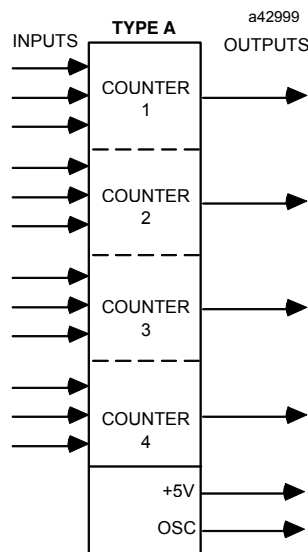

Each counter can be configured to count either up or down.

Elements of a Type A Counter (4 per block)

Each counter has a Preload Input, a Count Pulse input, and a Strobe Input. For counters 1 through 3 on the block, the Preload and Strobe Inputs are single-ended. For counter 4, the Strobe input may be differential. All inputs may be configured to accept either TTL-level or non-TTL-level signals.

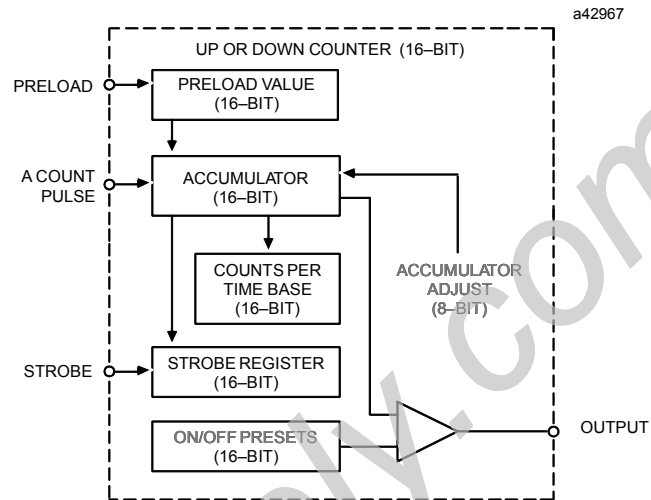

There are a Preload register, an Accumulator register, an Accumulator Adjustment register, a Counts per Timebase register, one Strobe Register, and one set of on/off Output Preset values. These are described on the following pages.

Preload Inputs

A Preload Input is used to set the Accumulator to the value in the Preload Register. If the Preload Input occurs during counting, the resulting Accumulator value will be within one count of the value in the Preload Register.

The Preload Register can be configured to contain any value within the counter's selected range, including 0.

The Preload Input is positive-edge sensitive. It can be configured to use the 2.5nS high-frequency filter, or the 12.5mS low-frequency filter, which will reduce the effect of signal noise.

If the Preload Input occurs, the block automatically notifies the host by setting the corresponding Preload Status bit. The host should monitor this bit, and if necessary, reset it using the Reset Preload output bit.

Count Pulse.

The count pulse increments the value in the Accumulator. It can be configured to use the 2.5 μ S high-frequency filter, or the 12.5mS low-frequency filter. Maximum count rates are 200kHz with the high-frequency filter or 40Hz with the low-frequency filter.

Counting occurs on the low-to-high transition of the Pulse input.

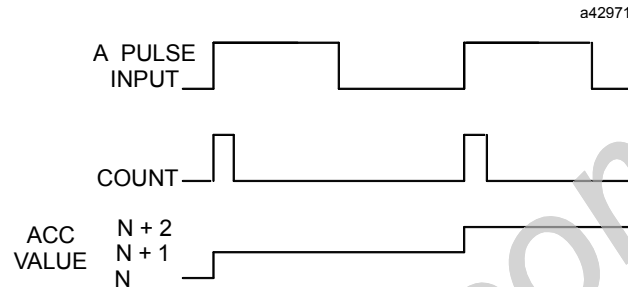

Accumulator

The Accumulator contains the current count value. Count limits for the Type A configuration are $-32,768$ to $+32,767$. Within this range, different limits can be selected by configuration.

If the counter is configured for *continuous counting mode*, the counter will wrap around if either limit is reached.

If the counter is configured for *single-shot counting mode*, it will count to either limit then stop. When a Preload Input is applied or the Accumulator is loaded from the CPU, the counter repeats the cycle. When the counter is at the limit, counts in the opposite direction will back it off the limit.

Accumulator Adjustment

The value in the Accumulator may be adjusted by sending the block a Write Data datagram from the CPU (see chapter 6). This adjustment may be any value between -128 and $+127$. The adjustment value is summed with the contents of the Accumulator.

Counts per Timebase Register

Each counter stores the number of counts that have occurred in a specified period of time. A timebase value from 1mS to 65535mS can be configured.

Strobe Input

The Strobe Input is edge-sensitive; it can be configured to respond to either the positive or negative edge. The Strobe Input always uses the 2.5nS high-frequency filter.

When the **Strobe Input** goes active, the block copies the current count value in the Accumulator to the corresponding **Strobe Register**. It automatically notifies the host by setting the appropriate **Strobe status bit**. The application program should monitor the status bits, and if a Strobe status bit is set, the application program should reset it using the corresponding **Reset Strobe output bit**.

The captured value remains in the Strobe Register until the Strobe Input goes active again, at which time it is overwritten. If the Latched Strobe mode is configured, subsequent strobe inputs will not overwrite the first strobe data until the Strobe status bit is cleared by the CPU. Each time the CPU acknowledges receipt of the Strobe status bit, the application program should clear it.

If the Strobe Input and the Preload Input go active in the same 0.5mS interval, the block sets both the Accumulator and the Strobe Register to the value in the Preload Register.

The Strobe Input can be configured to produce both the Strobe function and the Preload function on the same signal edge. In this case, the Strobe Register is set to the Accumulator value before the Accumulator is set to the Preload value.

Output Presets

The counter's output signal can be configured to go on and off when the Accumulator reaches configured on and off Preset values.

Type B Counter Operation

If "Type B" is selected during block configuration, the block has two 24-bit counters.

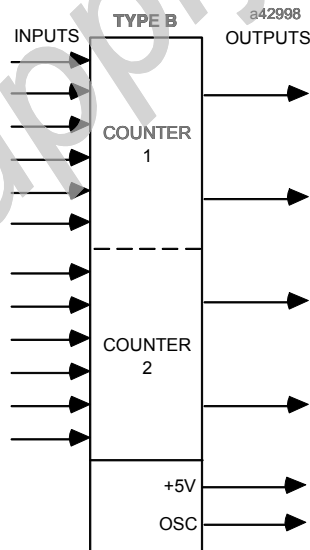

Each Type B counter can be configured for Up/Down, Pulse/Direction, or A-Quad-B operation.

Elements of a Type B Counter (2 per block)

Each counter has a Preload Input, two Count Pulse inputs, a Disable Input and two independent Strobe Inputs. There are two Strobe Registers, a 24-bit accumulator, an Accumulator Adjustment Register, and a Counts-per-Timebase Register. A Type B counter has two outputs with separate on/off Presets.

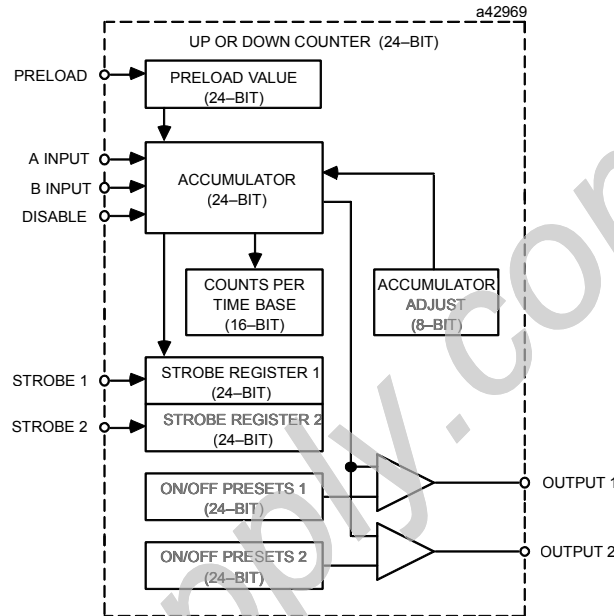

Preload

The Preload Input is used to set the Accumulator to the value in the Preload Register. If the Preload Input occurs during counting, the resulting Accumulator value will be within one count of the value in the Preload Register.

The Preload Register can be configured to any value within the counter's selected range.

The Preload Input is positive-edge sensitive. It can be configured to use the 2.5 μ S high-frequency filter, or the 12.5mS low-frequency filter, which will reduce the effect of signal noise.

If the Preload Input occurs, the block automatically notifies the host by setting the corresponding Preload Status bit. The host should monitor this bit, and if necessary, reset it using the Reset Preload output bit.

A and B Input

The A Input and B Input are count pulse inputs. They can be used for up/down, pulse/direction, or A-Quad-B counting. The count inputs can be independently configured to use the 2.5nS high-frequency filter, or the 12.5mS low-frequency filter.

Maximum count rates are 200kHz with the high-frequency filter, or 40Hz with the low-frequency filter.

Disable Input

The Disable Input, which is not available in the Type A configuration, can be used to inhibit counting. It is level sensitive, and active high. The Disable Input can use the high-frequency or low-frequency filter.

When active, all counts to the Accumulator and the Counts per Timebase register are inhibited. All other counter functions are unaffected.

Accumulator

The Accumulator contains the current count value. Count limits for the Type B configuration are $-8,388,608$ to $+8,388,607$. Within this range, other limits can be selected by configuration.

If the counter is configured for *continuous counting mode*, the counter will wrap around if either limit is reached.

If the counter is configured for *single-shot counting mode*, it will count to either limit then stop. When a Preload Input is applied or the Accumulator is loaded from the CPU, the counter repeats the cycle. When the counter is at the limit, counts in the opposite direction will back it off the limit.

Accumulator Adjustment

The value in the Accumulator may be adjusted by sending the block a Write Data datagram from the CPU (see chapter 6). This adjustment may be any value between -128 and $+127$. The adjustment value is summed with the contents of the Accumulator.

Counts per Timebase Register

Each counter stores the number of counts that have occurred in a specified period of time. A timebase value from 1mS to 65535mS can be configured.

Strobe Inputs

The Strobe Inputs are edge-sensitive; they can be configured to respond to either the positive or negative edge. Strobe Inputs always use the $2.5\mu\text{S}$ high-frequency filter.

When the Strobe Input goes active, the block copies the current count value in the Accumulator to the corresponding Strobe Register. It automatically notifies the host by setting the appropriate Strobe status bit. The application program should monitor the status bits, and if a Strobe status bit is set, the application program should reset it using the corresponding Reset Strobe output bit.

The captured value remains in the Strobe Register until the Strobe Input goes active again, at which time it is overwritten. If the Latched Strobe mode is configured, subsequent strobe inputs will not overwrite the first strobe data until the Strobe status bit is cleared by the CPU. Each time the CPU acknowledges receipt of the Strobe status bit, the application program should clear it.

If a Strobe Input and the Preload Input go active in the same 0.5mS interval, the block sets both the Accumulator and the Strobe Register to the value in the Preload Register.

Output Presets

Each of the counter's two output signals can be configured to go on and off when the Accumulator reaches configured on and off Preset values.

Counter Operation

The A Input and B Input of each Type B counter can be configured for Up/Down, Pulse/Direction, or A-Quad-B operation.

Operating in UP/DOWN Mode

If a counter is configured for Up/Down counting, up-counting occurs on the low-to-high transition of the Up input. Down counting occurs on the low-to-high transition of the Down input. The accumulator automatically tracks the difference between the number of counts received by the Up channel and the Down channel.

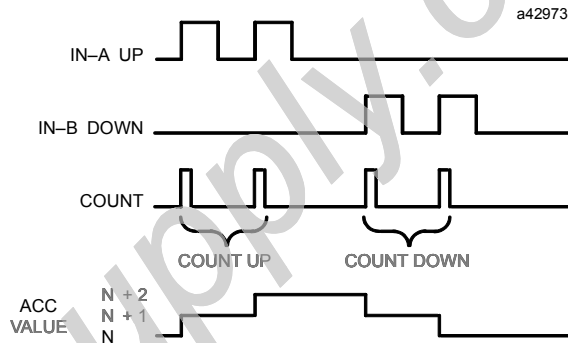

Operating in PUL/DIR Mode

If a counter is configured for Pulse/Direction counting, counting always occurs on the low-to-high transition of the Pulse input. Count direction is up for a low level on the Direction input and down for a high level on the Direction input. The polarity of the direction input may be changed at any time. It is advisable to change the DIR signal on the falling edge of the Pulse input. Avoid changing it co-incidentally with the rising edge. The Accumulator register will be automatically adjusted accordingly.

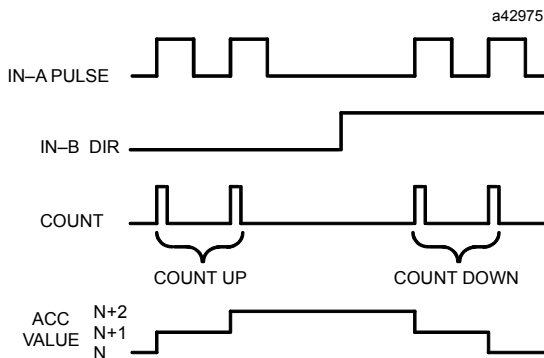

Operating in A-Quad-B Mode

If a counter is configured for A-Quad-B counting, a count occurs for each transition of *either A or B*. There are four counts for each A-Quad-B cycle. Counts are evenly spaced with respect to the input waveforms when the phase relationship between A and B is shifted by 1/4 cycle.

The phase relationship between A and B determines count direction, as shown below.

The count direction is up if A leads B.

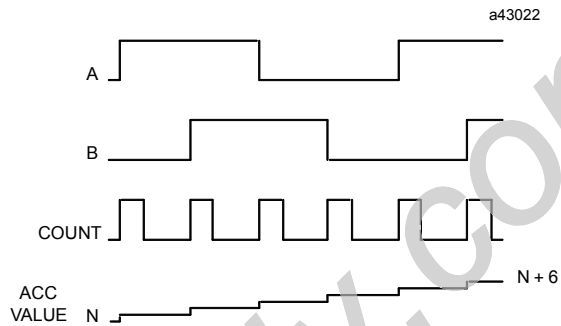

The count direction is down if A lags B.

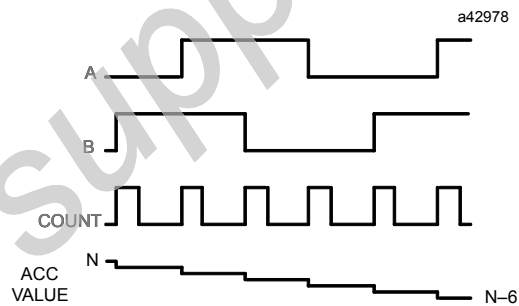

Type C Counter Operation

If the block should operate as one 24-bit differential counter, "Type C" is selected during block configuration. This configuration is suitable for applications requiring motion control, differential counting, or homing capability.

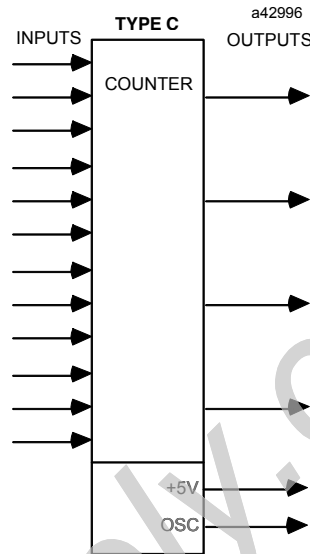

There are two sets of bi-directional counter inputs (+ and - loop).

The Plus and Minus Loop of a Type C Counter

In the Type C counter configuration, the plus (+) and minus (-) loops may be set up to operate independently in any mode (Up/Down, Pulse Direction, A-Quad-B).

Count Direction		Accumulator Function x = counts on (+) loop y = counts on (-) loop
(+) Loop	(-) Loop	
Up	Up	Differential (x-y)
Up	Down	Additive (x+y)
Down	Up	Additive (x+y)
Down	Down	Differential (y-x)
Up	no connection	Counts Up (x)
Down	no connection	Counts Down (-x)
no connection	Up	Counts Down (-y)
no connection	Down	Counts Up (y)

Changing the Count Direction

The integrity of the Accumulator is not affected by changing the count direction for either Pulse/Direction mode or A-Quad-B mode. Count direction may be changed at any time.

Elements of a Type C Counter (1 per block)

This counter uses all twelve of the block's inputs and all four outputs.

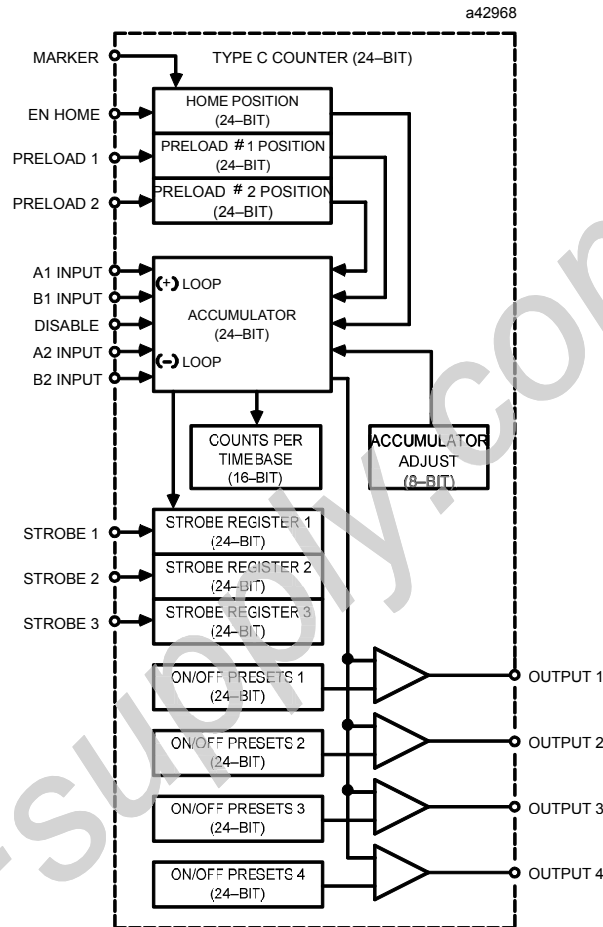

There are:

- Two sets of bi-directional Count inputs that can be connected to operate in a differential fashion. Each set can be configured for A-Quad-B, Up/Down, or Pulse/Direction mode.
- Three Strobe Registers with corresponding Strobe Inputs.
- Two Preload values with Preload Inputs.
- A Disable Input.
- A 24-bit Accumulator and an Accumulator Adjustment Register.
- A Home Position register for preloading the Accumulator to the Home Position value within one count period when the Enable Home input is active and the Marker pulse occurs.
- Four on/off Presets with outputs.

Home Found Marker

This input is used in homing applications to indicate that a Home position has been reached. It always uses the 2.5 μ S high-frequency filter. When this input occurs, the block preloads the Accumulator to the Home position value within one count period when the Enable Home input is active. An example application is shown in Appendix A.

Enable Home

This input indicates the present status of a home limit switch. The Enable Home input always uses the 12.5mS low-frequency filter.

Preload

The Preload Inputs are used to set the Accumulator to the value in one of the two Preload Registers.

The Preload Registers can be configured to contain any value within the counter's selected range.

Preload Inputs are edge-sensitive. They can be configured to use the 2.5 μ S high-frequency filter, or the 12.5mS low-frequency filter, which will reduce the effect of signal noise.

If a Preload Input occurs, the block automatically notifies the host by setting the corresponding Preload Status bit. The host should monitor this bit, and if necessary, reset it using the Reset Preload output bit.

A and B Inputs

The A and B Inputs are count pulse inputs. Each pair can be used for up/down, pulse/direction, or A-Quad-B counting. In addition, each pair can be independently configured to use the 2.5 μ S high-frequency filter, or the 12.5mS low-frequency filter. Maximum count rates are 200kHz with the high-frequency filter, or 40kHz with the low-frequency filter.

Disable Input

The Disable Input can be used to inhibit counting. It can also use the high-frequency or low-frequency filter. The Disable Input is level-sensitive, and active high.

When active, all counts to the Accumulator and the Counts per Timebase register are inhibited. All other counter functions are unaffected.

Accumulator

The Accumulator is the "Summing Function" of the '+' loop and the '-' loop. The '+' loop is made up of inputs A1 and B1, the '-' loop is made of inputs A2 and B2.

Count limits for the Type C configuration are -8,388,608 to +8,388,607. Within this range, other limits can be selected by configuration.

If the counter is configured for *continuous counting mode*, the counter will wrap around if either limit is reached.

If the counter is configured for *single-shot counting mode*, it will count to either limit then stop. When a Preload Input is applied or the Accumulator is loaded from the CPU, the

counter repeats the cycle. When the counter is at the limit, counts in the opposite direction will back it off the limit.

If any combination of Preload #1, Preload #2, or Home Found Marker inputs go active in the same 0.5mS interval, the Accumulator will be set to the value according to the following priority:

1. Home Found
2. Preload #1
3. Preload #2

Accumulator Adjustment.

The value in the Accumulator may be adjusted by sending the block a Write Data datagram from the CPU (see chapter 6). This adjustment may be any value between -128 and +127. The adjustment value is summed with the contents of the Accumulator.

Counts per Timebase Register

Each counter stores the number of counts that have occurred in a specified period of time. A timebase value from 1mS to 65535mS can be configured.

Strobe Inputs

The Strobe Inputs are edge-sensitive; they can be configured to respond to either the positive or negative edge. Strobe Inputs always use the 2.5 μ S high-frequency filter.

When a Strobe Input goes active, the block copies the current count value in the Accumulator to the corresponding Strobe Register. It automatically notifies the host by setting the appropriate Strobe status bit. The application program should monitor the status bits, and if a Strobe status bit is set, the application program should reset it using the corresponding Reset Strobe output bit.

The captured value remains in the Strobe Register until the Strobe Input goes active again, at which time it is overwritten. If the Latched Strobe mode is configured, subsequent strobe inputs will not overwrite the first strobe data until the Strobe status bit is cleared by the CPU. Each time the CPU acknowledges receipt of the Strobe status bit, the application program should clear it.

Output Presets

Each of the counter's two output signals can be configured to go on and off when the Accumulator reaches configured on and off Preset values.

Timing for Type C Counter

The following information applies to the positive (+) loop of a type C counter. The relationship between the input signals and the internal count pulse remains the same in the negative (-) loop, but the effect of the pulse is negated. Count pulses that would result in an increment to the Accumulator value on the (+) loop will result in a decrement on the (-) loop, and vice-versa.

Operating in UP/DOWN Mode

If the counter is configured for Up/Down counting, up-counting occurs on the low-to-high transition of the Up input. Down counting occurs on the low-to-high transition of the Down input.

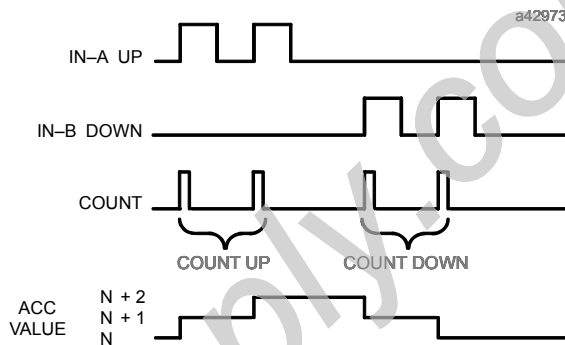

Operating in PUL/DIR Mode

If the counter is configured for Pulse/Direction counting, counting always occurs on the low-to-high transition of the Pulse input. Count direction is up for a low level on the Direction input and down for a high level on the Direction input. The polarity of the direction input may be changed at any time. It is advisable to change the DIR signal on the falling edge of the Pulse input. Avoid changing it co-incidentally with the rising edge. The Accumulator register will be automatically adjusted accordingly.

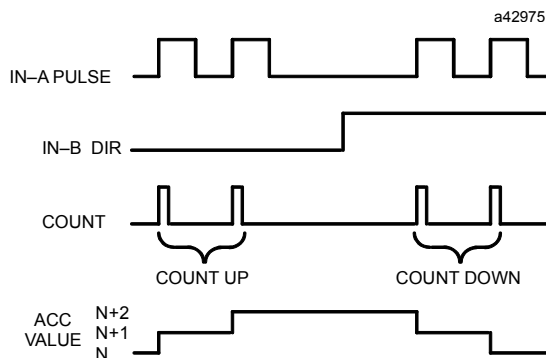

Operating in A-QUAD-B Mode

If the counter is configured for A-Quad-B counting, a count occurs for each transition of either A or B. There are four counts for each A-Quad-B cycle. The counts are evenly spaced with respect to the input waveforms when the phase relationship between A and B is shifted by 1/4 cycle.

The phase relationship between A and B determines count direction, as shown below.

The count direction is up if A leads B.

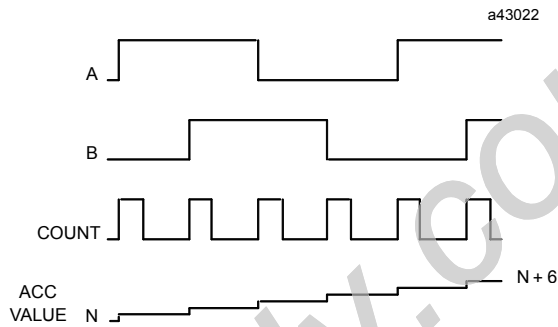

The count direction is down if A lags B.

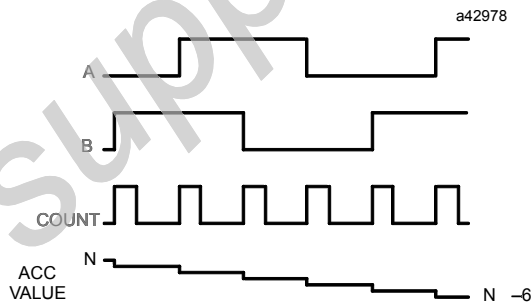

Differential Counting

Operation of the Accumulator in a typical differential application is illustrated below.

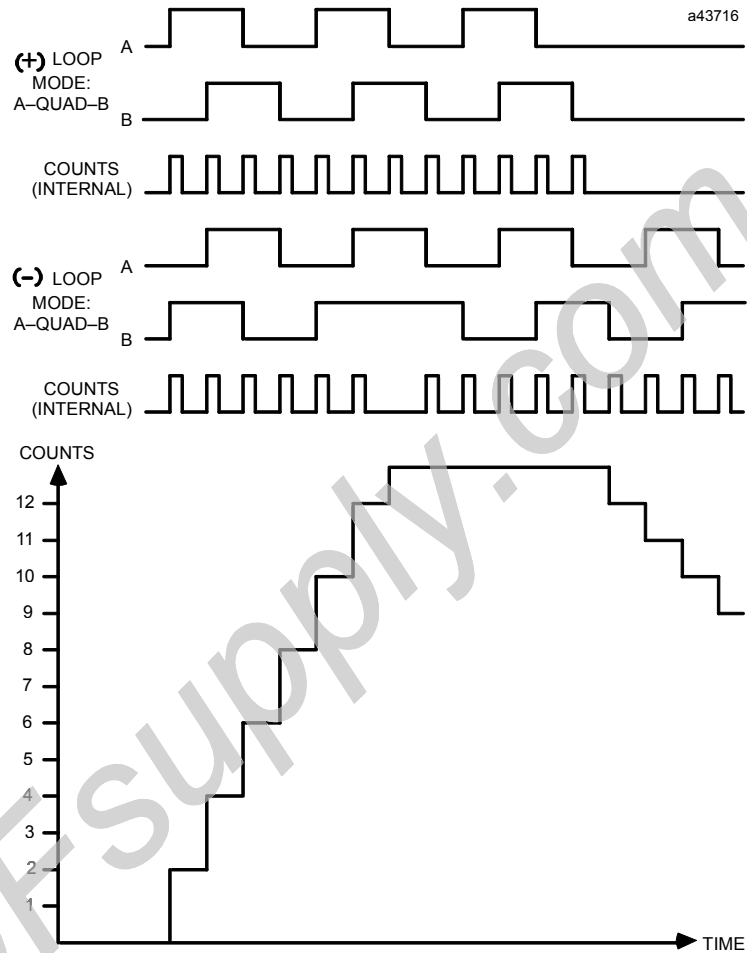

Configuration

A High-speed Counter block has many characteristics that can be configured from a Hand-held Monitor or from the application program.

Use a Hand-held Monitor, as instructed in chapter 3, to configure the block's:

- Baud rate.
- Reference Number.
- Device Number (Block ID).
- Counter type: Type A (4 counters) Type B (2 counters) Type C (1 counter)

Use an HHM (see chapter 3) or an application program command (see chapter 6) to configure:

- Pulse-testing of outputs at powerup.
- Automatic operation of outputs following powerup.
- Oscillator frequency for the block's OSC output signal.
- Control inputs for TTL or non-TTL signals.
- Counter inputs for TTL or non-TTL signals.
- Strobe linkage for Type B counter.
- CPU fault reports.
- Strobe Input(s) active edge (positive or negative).
- Strobe Input(s) latched to Strobe status bit.
- Input Filter for Preload, Count, and Disable Inputs.
- Count direction (Up/Down) or counter operation (Up/Down, Pulse/Direction, A-Quad-B).
- Continuous counting or single-shot counting.
- Counter timebase from 1mS to 65535mS.
- Upper and lower count limits.
- Output Preset on and off values.
- Home position for Type C counter.
- Preload value for Accumulator.
- CPU Redundancy.
- Configuration Protection.

Temporary Configuration Changes

Make these temporary changes to the block's configuration by sending the block a datagram from the application program (see chapter 6):

- Current Accumulator value.
- Count limits.
- Counter direction (Type A counter only).
- Counter Timebase.
- Home position (Type C counter only).
- Output On/Off Presets.
- Preload Register value(s).
- Oscillator frequency for OSC output.

PDFSupply.com

Monitoring/Controlling Operation of the Block

Operation of the block can be monitored and controlled from a Hand-held Monitor or from the application program.

Use a Hand-held Monitor (see chapter 4) to:

- Locate/clear output faults.
- Identify forced outputs.
- Force outputs.
- Remove output forces.

Use the HHM (see chapter 4) or an Application Program Command (see chapter 5) to:

- Read the actual states of control inputs (Disable, Home, Preload, Strobe).
- Read the current Accumulator value.
- Read latest Counts-per-Timebase value.
- Read Strobe Register(s).
- Read current output states.

Perform these Actions from the Application Program (see chapter 5):

- Read the current module status to determine successful powerup.
- Reset a Strobe Input bit after a Strobe Input occurs.
- Reset a Preload Input after a Preset input changes.
- Set/clear a bit in the block's output references.
- Enable or disable Preset Outputs.
- Read Output Presets (may also be read from HHM configuration screen).

Chapter 2

Installation

This chapter describes installation and field wiring for the High-speed Counter block.

- Mounting the block
- Grounding
- Serial bus wiring
- Block power wiring
- Block terminal assignments
- Typical field wiring connections for Type A, Type B, and Type C block configurations.

Mounting the Block

The block can be mounted either right-side up or upside-down. Drill two screw or bolt holes for 8-32 hardware. Notice that the holes are not centered on the block. Position the block so that the notches in the upper and lower flanges line up with the mounting holes. Attach the block using 8-32 screws with star washers.

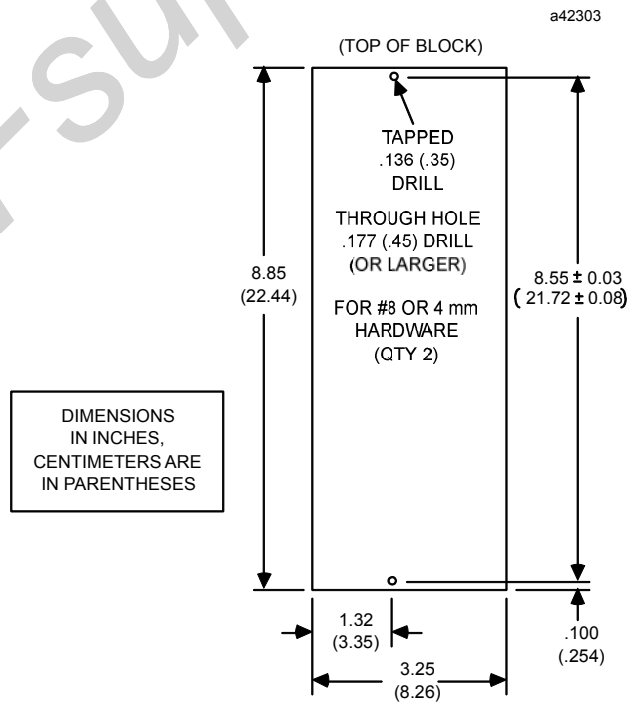

Grounding

Connect the grounding screw on the block to a reliable ground system, using a short ground strap. Otherwise, the casing of the block's Electronics Assembly will be floating with respect to ground.

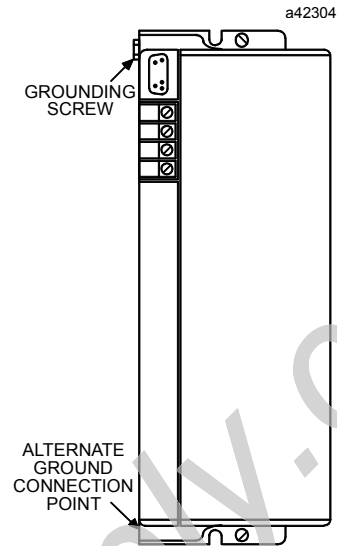

Warning

**If the block is not properly grounded, electrical shock hazard exists.
Death or personal injury may result.**

Block Wiring

The High-speed Counter block has 46 wiring terminals. Terminals 1 - 4 are for connection of the serial bus. Terminals 5 through 46 are for block power, and field devices.

Field wiring for each block configuration (Type A, Type B, or Type C) is shown in this chapter.

Equipment Required

Terminals 1 - 4 are standard screw, clamp-type terminals that can be operated with either a flat or Phillips-head screwdriver. Terminals 1 - 4 can each accept one AWG #12 or AWG #14 wire. The minimum recommended wire size is AWG #22. Terminals 1 - 4 can accommodate spade or ring terminals up to 0.27 inch (6.85 mm) in width with a minimum opening for a #6 screw, and up to 0.20 inch (5.1mm) depth from the screw center to the back barrier.

Terminals 5 - 46 are for field wiring. These terminals require a 1/8 inch flat screwdriver. Each terminal accepts one AWG #14 wire. Minimum recommended wire size is AWG #22.

Wiring the Serial Bus (terminals 1-4)

Terminals 1 - 4 are used for the serial bus connections. Selection of the correct type of cable for the application is explained in detail in the *Genius I/O System User's Manual*. Proper cable selection is essential to successful operation of the bus.

Basic Bus Wiring

To complete the bus wiring, connect the Serial 1 terminal (terminal 1) to the Serial 1 terminals of the previous and following devices. Similarly, connect the Serial 2 terminal (terminal 2) to the Serial 2 terminals of the adjacent devices. Connect Shield In (terminal 3) to the Shield Out terminal of the previous device. Connect Shield Out (terminal 4) to the Shield In terminal of the next device. Terminate the Serial 1 and Serial 2 lines at either end with a resistor which matches the impedance of the cable used.

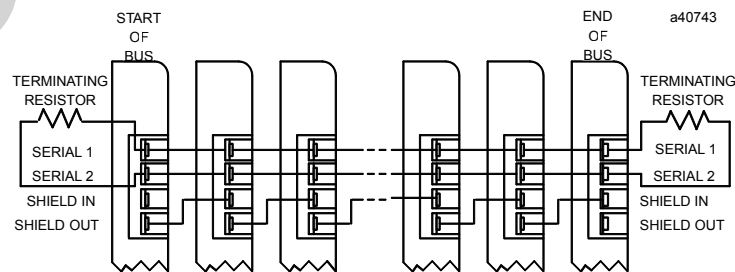

Installing the Block at the End of the Bus

If the block is at the beginning of the bus, its Shield In terminal is not connected. If the block is at the end of the bus, its Shield Out terminal is not connected.

If the block is at either end of the bus, terminate the bus by installing an appropriate terminating resistor across the Serial 1 and Serial 2 terminals. Impedance will be 75, 100, 120, or 150 ohms. The impedance selected must be correct for the cable type used for the bus. 150 ohm (IC660BLM506) and 75 ohm (IC660BLM508) resistor plugs are provided with each Series Six Bus Controller, and can also be ordered separately.

Bus Connection for Critical Processes

The recommended method of connecting the block to the bus is to wire it directly to the block's Terminal Assembly as described above. These bus connections are normally considered permanent. They should never be removed while the completed system is in operation; the resulting unreliable data on the bus could cause hazardous control conditions. If the possible removal or replacement of a block's Terminal Assembly would result in breaking the continuity of the bus, the bus should be turned off first.

If the bus controls critical processes that cannot be shut down, blocks can be wired to the bus via an intermediate connector, as shown below.

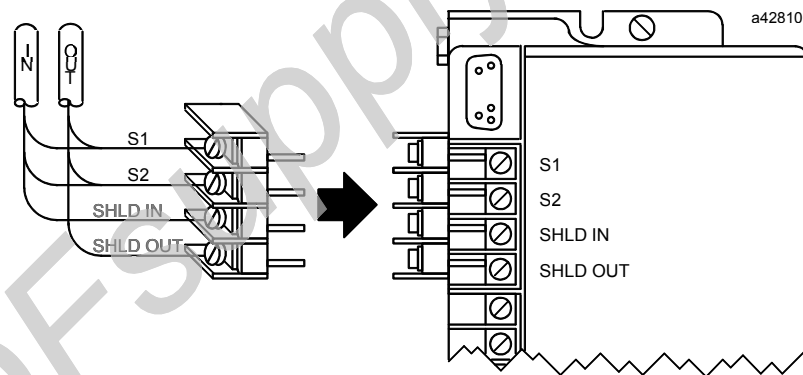

This will allow the block's Terminal Assembly to be removed while maintaining data integrity on the bus. The connector shown is #A107204KNELL from Control Design, 11124 Downs Rd, Pineville, NC, 28134. If blocks are connected to the bus in this way, field wiring to the blocks should also provide a means of disconnecting power to individual blocks.

Alternatively, the wire ends can be soldered together before inserting them into the block terminals. When removing the Terminal Assembly, cover the ends of the wires with tape to prevent shorting the signal wires to one another or to ground.

Block Power Connections

The block may be powered by 115VAC (at 60mA, typical) or 10VDC to 30VDC (at 250mA typical). If the block is powered by an AC source, DC power can also be applied as a backup.

AC Block Power

For an AC block power source, connect the HOT lead to the H terminal. Connect neutral to the N terminal.

NOTE

If Class 1 Division 2 conditions must be met for Factory Mutual, install an external 250-volt 1/8 amp slow-blow fuse in series with the H terminal.

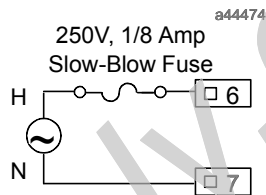

This illustration shows connections for AC block power with an external DC source for the outputs (see “Output Power Connections”, below).

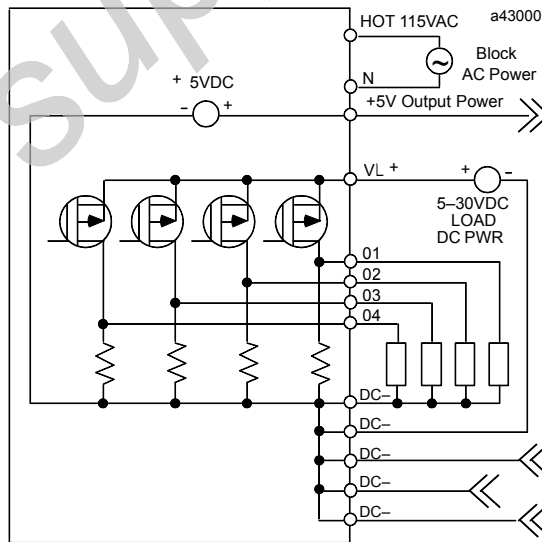

AC Block Power with DC Backup

When using AC block power, DC power may also be connected as a backup. Any 10 to 30 VDC source can be used. With both AC and DC power applied, block power is taken from the AC input if the DC voltage is less than 20 volts. Above 20 volts, block power is drawn from the DC input, even if AC power is still applied. Connect the AC source to the Hot and Neutral terminals. Connect the DC backup to DC+ and DC-. The following illustration shows connections for AC block power with DC backup, and output power from the block's 5-volt output. (See "Output Power Connections").

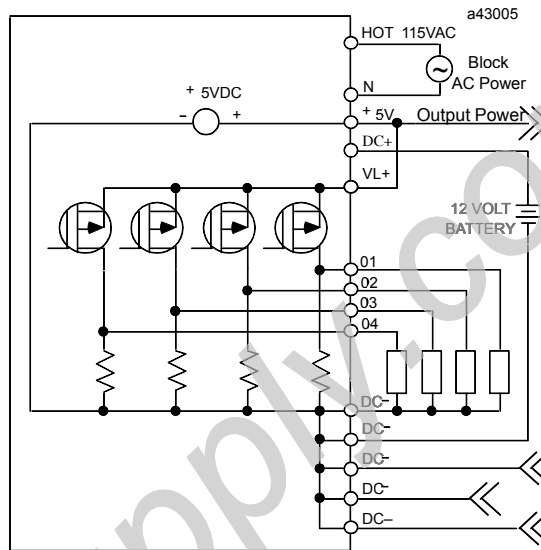

DC Block Power

If the block will be powered by a 10VDC to 30VDC source, connect the + side of the source to DC+ (terminal 13). Connect the - side to any DC- terminal (terminals 42 through 46). The following illustration shows connections for DC block power with a separate external DC source for the outputs (see "Output Power Connections").

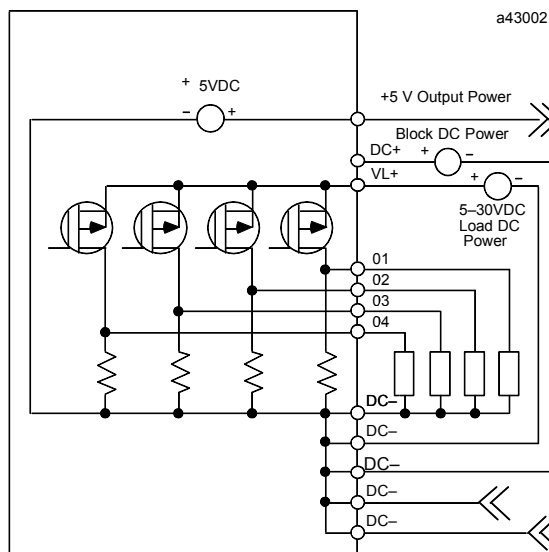

Output Power Connections

The block's four outputs (O1 through O4) require a 5VDC to 30VDC source. If logic-level signals are needed for the outputs and their total load will not be more than 200mA, the block's +5V output can be used as the power source. Output power can also come from the same DC source used for block power, or a separate DC power source.

Connecting VL+

If no block outputs (O1 through O4) will be used, jumper the block's +5V output to VL+. If VL+ is not connected, the block will generate false Failed Switch messages.

Output Power from the +5V Terminal

To use the block's +5VDC output as the output power source, jumper the +5 volt output terminal to VL+. See the illustration for "AC Block Power with DC Backup".

Output Power from the DC Block Power Source

If outputs will be powered by the same DC source used for block power, jumper VL+ to DC+.

Output Power from a Separate DC Source

If output power will come from a separate external DC source (not the same power supply used for block power), install the external source across the VL+ and DC- terminals.

Field Wiring Connections

Terminal assignments for the block are shown on the following pages. Refer to the section that corresponds to the configuration of the block (Type A, B, or C). For all configurations, follow the general instructions below.

Connecting Signals to Differential Terminals

Connect differential inputs to the terminals as indicated in the diagram. Connect the + input to the + terminal, and the - input to the - terminal. For single-ended signals (abbreviated "se" in each diagram), make a connection to the + differential terminal only. Leave the - terminal unconnected.

+5 Volt Output

For both AC and DC block power, the +5V terminal (terminal 14) can be used to drive any load, including output loads, that falls within its capacity of 4.75 to 5.25 volts at 200 mA. The return or (-) of all external sources used with the block should be connected to the DC- terminal of the block.

Caution

Do not apply loads greater than 200mA to the +5V output (terminal 14). Doing so may damage the block.

NOTE

If the block is powered up with the Powerup Pulse Test feature enabled, but no DC load voltage is connected to the VL+ terminals, Failed Switch diagnostics will be reported (see page 6-7).

OSC

Terminal 36, labelled OSC, is a CMOS/TTL compatible totempole output that will source 3.8V at 4mA. Do not use an external pullup resistor for this terminal.

O1 - O4

The terminals labelled O1 through O4 are for outputs that will be driven by a DC power supply wired to VL+ (terminal 15). This voltage may vary from 5 volts to 30 volts DC, depending on the output level needed. The maximum steady-state current supplied by any output is 0.5 Amp.

Terminal Assignments: Type A

Refer to the following terminal assignments for a block configured as Type A.

TERMINAL CONTACT	SIGNAL NAME	DESCRIPTION	a42979
1	SERIAL 1	serial communications bus	
2	SERIAL 2	serial communications bus	
3	SH IN	shield for serial bus	
4	SH OUT	shield for serial bus	
5	HOT	for hot side of AC line	
6	NC	no connection	
7	NC	no connection	
8	NC	no connection	
9	N	for neutral side of AC line	
10	NC	no connection	
11	NC	no connection	
12	NC	no connection	
13	DC +	block power (+ side 10–30V source)	
14	+ 5V	+5V output at 200mA	
15	VL+	load power (+ side 5–30V source)	
16	I1 +	pulse input for ctr 1 (se/diff)	
17	I2 +	pulse input for ctr 2 (se/diff)	
18	I1 -	pulse input for ctr 1 (diff only)	
19	I2 -	pulse input for ctr 2 (diff only)	
20	I3 +	pulse input for ctr 3 (se/diff)	
21	I4 +	pulse input for ctr 4 (se/diff)	
22	I3 -	pulse input for ctr 3 (diff only)	
23	I4 -	pulse input for ctr 4 (diff only)	
24	SHD	shield	
25	SHD	shield	
26	C1	preload 1	
27	C2	preload 2	
28	C3	preload 3	
29	C4	preload 4	
30	C5	strobe 1	
31	C6	strobe 2	
32	C7	strobe 3	
33	C8 +	strobe 4 (se/diff)	
34	SHD	shield	
35	C8 -	strobe 4 (diff only)	
36	OSC	oscillator output	
37	SHD	shield	
38	O1	output 1	
39	O2	output 2	
40	O3	output 3	
41	O4	output 4	
42	DC -	return for all DC sources	
43	DC -	return for all DC sources	
44	DC -	return for all DC sources	
45	DC -	return for all DC sources	
46	DC -	return for all DC sources	

Typical Input Circuit and Count Input Connections for a Block Configured as Type A

Counter 1

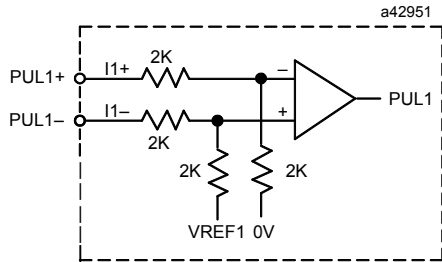

Counter 2

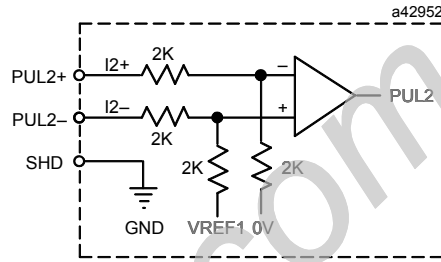

Counter 2

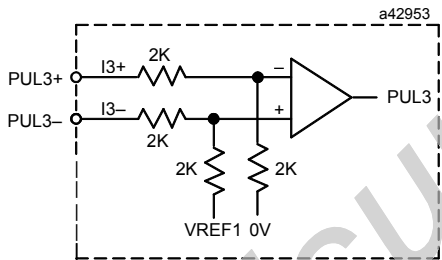

Counter 4

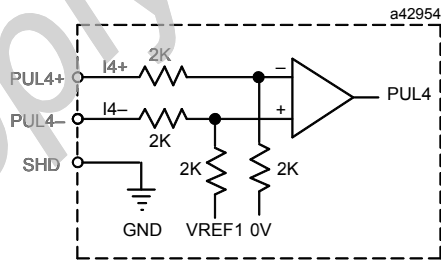

Leave the '-' input unconnected for differential inputs used single-endedly.

Terminal Assignments: Type B

Refer to the following terminal assignments for a block configured as Type B.

TERMINAL CONTACT	SIGNAL NAME	DESCRIPTION	a42980
1	SERIAL 1	serial communications bus	
2	SERIAL 2	serial communications bus	
3	SH IN	shield for serial bus	
4	SH OUT	shield for serial bus	
5	HOT	for hot side of AC line	
6	NC	no connection	
7	NC	no connection	
8	NC	no connection	
9	N	for neutral side of AC line	
10	NC	no connection	
11	NC	no connection	
12	NC	no connection	
13	DC +	block power (+ side 10–30V source)	
14	+5V	+5V output at 200mA	
15	VL +	load power (+ side 5–30V source)	
16	I1 +	pul1 / up1 / A1 + for ctr 1 (se/diff)	
17	I2 +	dir 1 / dn1 / B1 + for ctr 1 (se/diff)	
18	I1 -	pul1 / up1 / A1 - for ctr 1 (diff only)	
19	I2 -	dir1 / dn1 / B1 - for ctr 1 (diff only)	
20	I3 +	pul 2 / up2 / A2 + for ctr 2 (se/diff)	
21	I4 +	dir 2 / dn2 / B2 + for ctr 2 (se/diff)	
22	I3 -	pul2 / up2 / A2 - for ctr 2 (diff only)	
23	I4 -	dir2 / dn2 / B2 - for ctr 2 (diff only)	
24	SHD	shield	
25	SHD	shield	
26	C1	preload 1	
27	C2	preload 2	
28	C3	disable 1	
29	C4	disable 2	
30	C5	strobe 1 for counter 1	
31	C6	strobe 2 for counter 1	
32	C7	strobe 1 for counter 2	
33	C8 +	strobe 2 for counter 2 (se/diff)	
34	SHD	shield	
35	C8 -	strobe 2 for counter 2 (diff only)	
36	OSC	oscillator output	
37	SHD	shield	
38	O1	output 1 for counter 1	
39	O2	output 2 for counter 1	
40	O3	output 1 for counter 2	
41	O4	output 2 for counter 2	
42	DC -	return for all DC sources	
43	DC -	return for all DC sources	
44	DC -	return for all DC sources	
45	DC -	return for all DC sources	
46	DC -	return for all DC sources	

Typical Input Circuit and Count Input Connections for a Block Configured as Type B

(Counter 1 shown, for Counter 2 substitute PUL2 for PUL1, etc.)

Counter 1 (PUL/DIR Mode)

Counter 1 (UP/DN Mode)

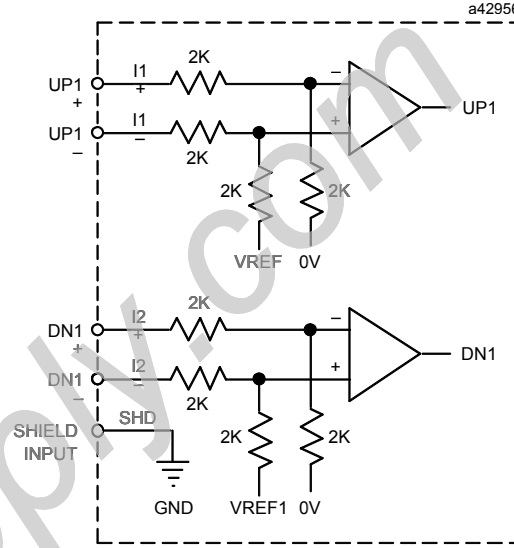
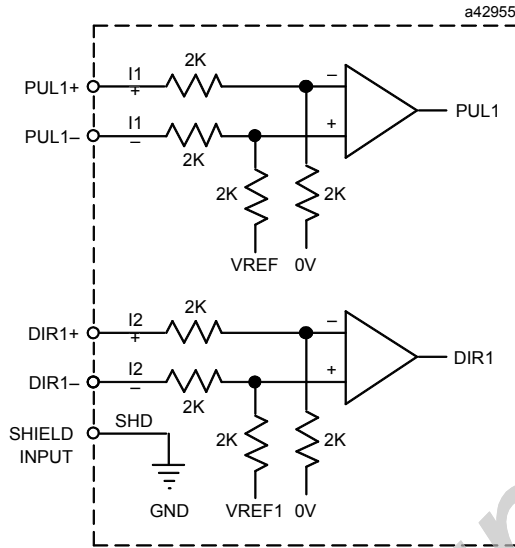

Leave the '-' input unconnected for differential inputs used single-endedly.

Counter 1 (A-Quad-B Mode)

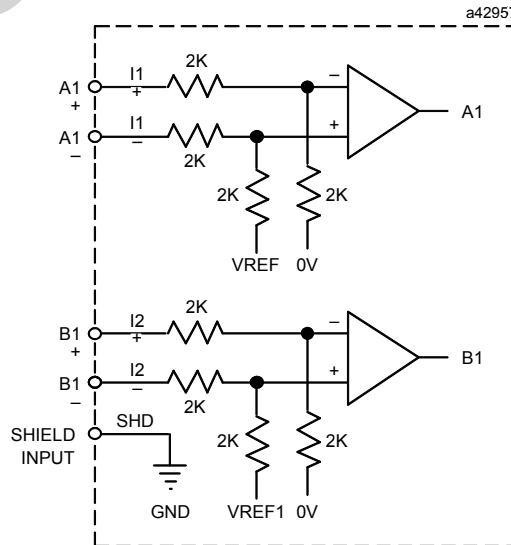

Leave the '-' input unconnected for differential inputs used single-endedly.

Terminal Assignments: Type C

Refer to the following terminal assignments for a block configured as Type C.

TERMINAL CONTACT	SIGNAL NAME	DESCRIPTION	a42981
1	SERIAL 1	serial communications bus	
2	SERIAL 2	serial communications bus	
3	SH IN	shield for serial bus	
4	SH OUT	shield for serial bus	
5	HOT	for hot side of AC line	
6	NC	no connection	
7	NC	no connection	
8	NC	no connection	
9	N	for neutral side of AC line	
10	NC	no connection	
11	NC	no connection	
12	NC	no connection	
13	DC +	block power (+ side 10–30V source)	
14	+ 5V	+ 5V output at 200mA	
15	VL +	load power (+ side 5–30V source)	
16	I1 +	pul1 / up1 / A1 + for ctr 1 (se/diff)	
17	I2 +	dir1 / dn1 / B1 + for ctr 1 (se/diff)	
18	I1 -	pul1 / up1 / A1 - for ctr 1 (diff only)	
19	I2 -	dir1 / dn1 / B1 - for ctr 1 (diff only)	
20	I3 +	pul1 / up1 / A1 + for ctr 2 (se/diff)	
21	I4 +	dir1 / dn1 / B1 + for ctr 2 (se/diff)	
22	I3 -	pul1 / up1 / A1 - for ctr 2 (diff only)	
23	I4 -	dir1 / dn1 / B1 - for ctr 2 (diff only)	
24	SHD	shield	
25	SHD	shield	
26	C1	preload 1	
27	C2	preload 2	
28	C3	disable 1	
29	C4	enable home input [e.g., limit switch]	
30	C5	strobe 1	
31	C6	strobe 2	
32	C7	strobe 3	
33	C8 +	marker input from encoder (se/diff)	
34	SHD	shield	
35	C8 -	marker input from encoder (se/diff)	
36	OSC	oscillator output	
37	SHD	shield	
38	O1	output 1	
39	O2	output 2	
40	O3	output 3	
41	O4	output 4	
42	DC -	return for all DC sources	
43	DC -	return for all DC sources	
44	DC -	return for all DC sources	
45	DC -	return for all DC sources	
46	DC -	return for all DC sources	

Typical Input Circuit and Count Input Connections for a Block Configured as Type C

Positive Loop (PUL/DIR Mode)

Negative Loop (PUL/DIR Mode)

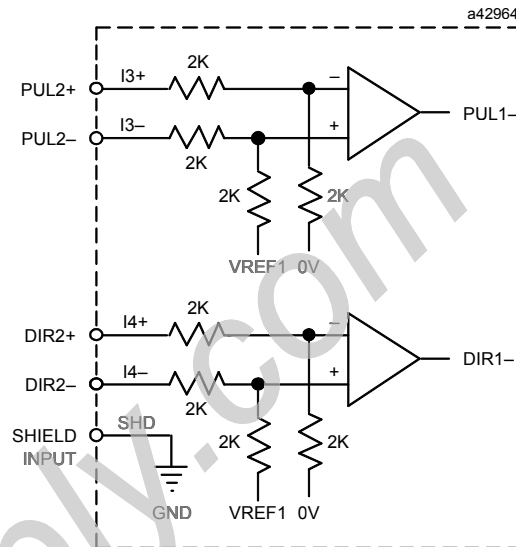
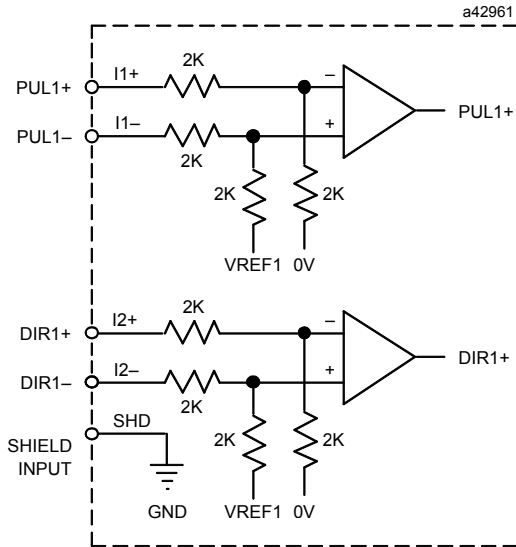

Leave the - input unconnected for differential inputs used single-endedly.

Negative Loop (PUL/DIR Mode)

Negative Loop (UP/DN Mode)

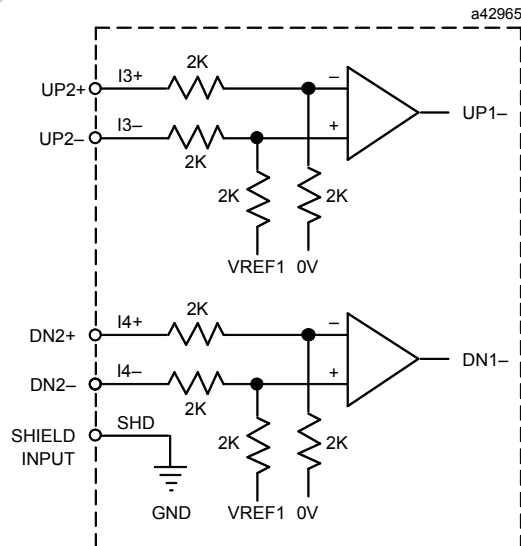
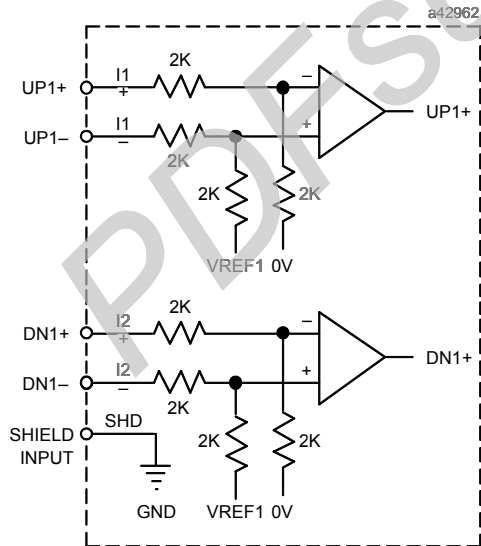

Leave the - input unconnected for differential inputs used single-endedly.

Typical Input Circuit and Count Input Connections for a Block Configured as Type C
(continued)

Positive Loop (A-Quad-B Mode)

Negative Loop (A-Quad-B Mode)

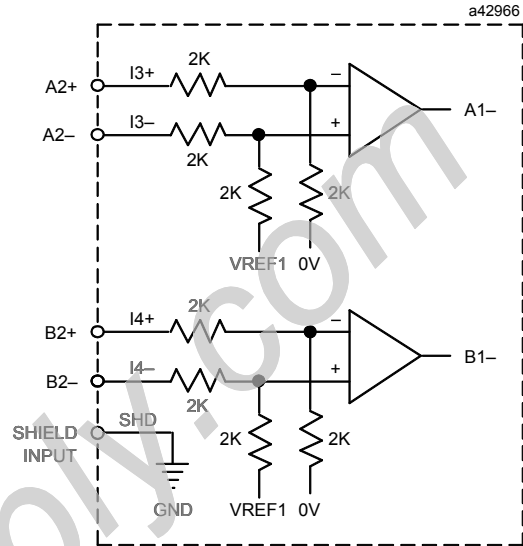
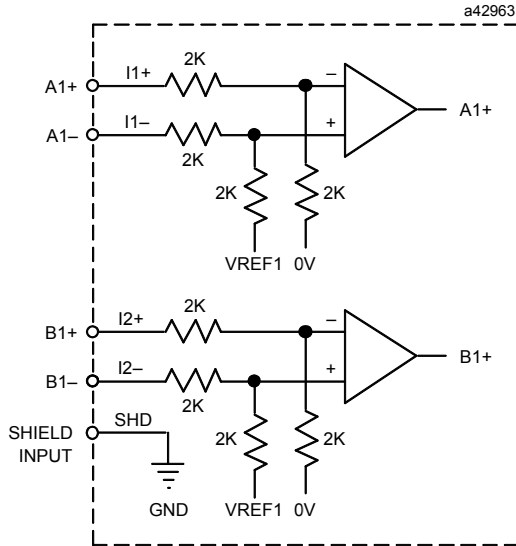

Encoder Connections

Connections for Encoders Requiring 12V Power: Positive Loop

Encoder Wiring in Differential Configuration: Positive Loop

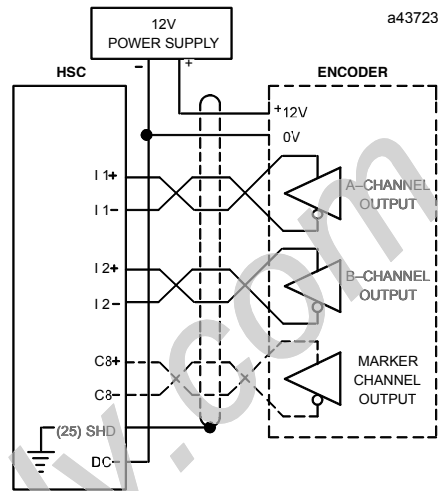
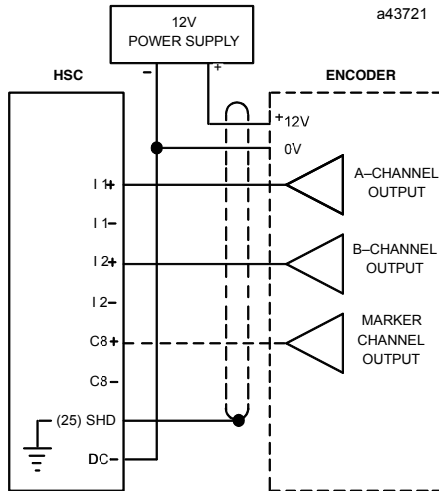

Connections for Encoders Requiring 12V Power: Negative Loop

Encoder Wiring in Differential Configuration: Negative Loop

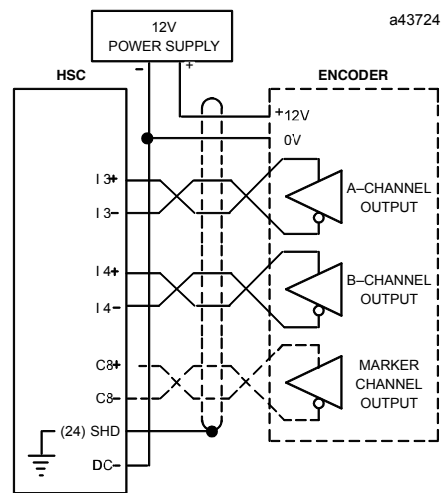
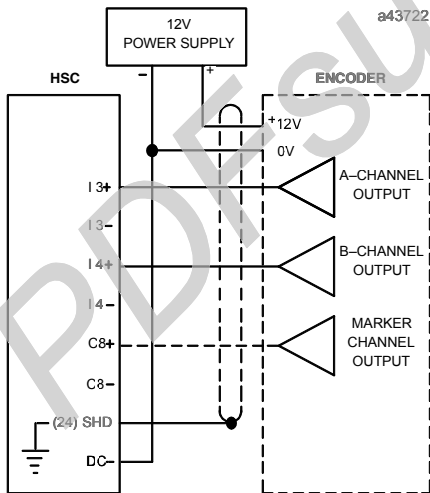

Wiring for Control Signals

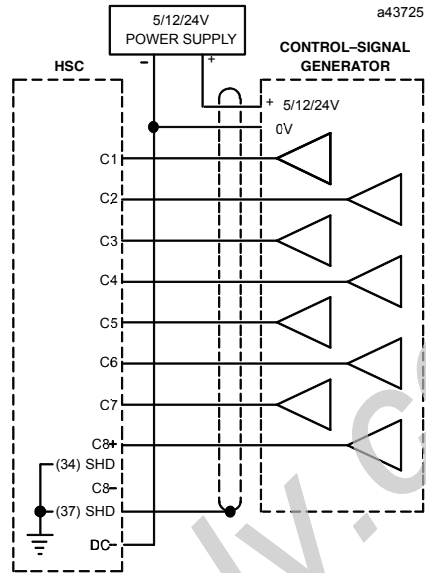

Wiring for TTL Open-Collector Input Devices

For TTL open-collector inputs, an external resistor must be provided. Be sure the input device is capable of handling the load current represented by the suggested resistor value.

Open-collector Input Device with +5 Volt Power Provided by the High-speed Counter

When using +5 volt power provided by the High-speed Counter, use a nominal pullup resistor of 1K ohm, 1/4 Watt, 5%.

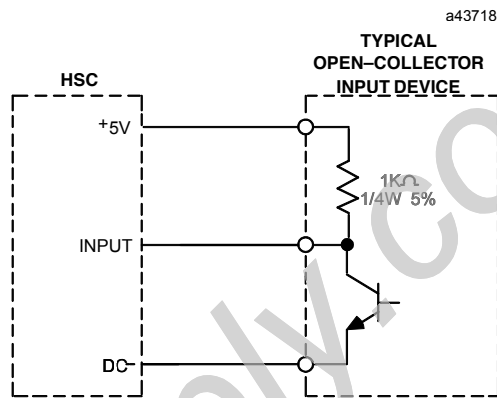

For an external power supply, suggested nominal resistors are:

1K ohm, 1/4 Watt, 5% for a +5 volt supply.

1.5K ohm, 1/4 Watt, 5% for a +12 volt supply.

4.7K ohm, 1/4 Watt, 5% for a +24 volt supply.

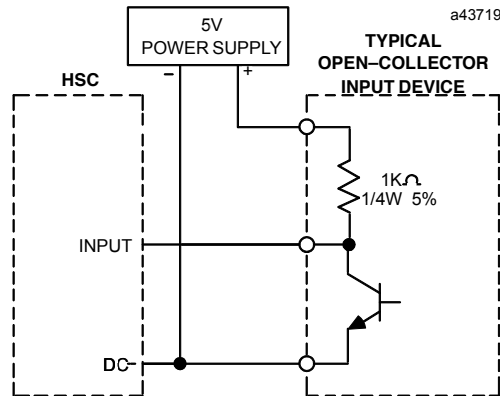

Chapter 3

Configuration

This chapter describes:

- How to configure a High-speed Counter block using a Hand-held Monitor (HHM).
- The configurable features of the High-speed Counter:

- Block ID
- ReferenceNumber
- Counter type (Type A, B, or C)
- Baud rate
- Pulse Test outputs at powerup
- Outputsenabled/disabledatpowerup
- Oscillatorfrequency
- Control and count inputs thresholds
- Fault reports (FAILED SWITCH)
- Strobe edge active, Strobe mode, Strobe effect, and Strobe linkage
- Disable, Preload, and Count input filters
- Count direction (Type A only)
- Counter Signal mode (Types B and C only)
- Continuous or single-shot counting
- Timebase for measuring count rate
- Upper and lower count limits
- On and off Presets for outputs
- Home position (Type C only)
- Preload counter value
- CPU redundancy
- Configuration protection

Required Features

The following required features of a High-speed Counter must be selected using a Hand-held Monitor:

Feature	Selections	Default
Block ID	0 To 31	none
ReferenceNumber	1 To 65535	none
Block type	Type A (4 up or down counters) Type B (2 up/down counters) Type C (1 counter, up/down and differential)	Type A

Other Configurable Features

The block has additional features that can be configured to suit the application. For many of these selectable features, the block is supplied with a default configuration that may not need to be changed.

Feature	Selections	Default
Baud Rate	153.6 std 153.6 ext, 76.8, 38.4 Kbaud	153.6Kbstd
Pulse Test	enabled/disabled	enabled
Outputs Enabled at Powerup	enabled/disabled	disabled
Oscillator Frequency (kHz)	1360/N 70/N 0.625/N	170/N(10kHz)
Divider (N)	1-255	17
Control Input Threshold	TTL/nonTTL	non-TTL
Counter Input Threshold	TTL/nonTTL	non-TTL
Strobe Linkage ****	independent, coupled to Accumulator 2	independent
Report Faults	yes/no	yes
Strobe edge	positive/negative	positive
Strobe Mode	not latched (last), latched (first)	not latched
Strobe Effect *	Strobe only, Strobe then Preload	Strobe only
Disable Input filter **	high/lowfrequency	high frequency
Preload Input filter	high/lowfrequency	high frequency
Count input filter	high/lowfrequency	high frequency
Count Up or Down *	Up/down	up counter
Count input signals **	UP/DN;PUL/DIR, A-QUAD-B	PUL/DIR
Count mode	Continuous/singleshot	continuous
Counter timebase	1 - 65535mS	1000mS
Count limits	A: -32768 to +32767 B/C: -8388608 to +8388607	upper = max + lower = 0
Output Preset positions	select ON and OFF positions	ON Presets = max + OFF Presets= 0
Home position value ***	enter home count value	0
Preload value	A: -32768 to +32767 B/C: -8388608 to +8388607	0
CPU Redundancy	none/standby	no redundancy
Configuration Protect	enabled/disabled	disabled

* for type A configuration only

*** for type C configuration only

** for type B or type C configuration

**** for type B configuration only

The features listed above can be configured either from the Hand-held Monitor or the application program. Also, the block's configuration can be changed while it is counting. If the counter is operating at a count rate of 150kHz or higher, run-time configuration changes should be made using a Hand-held Monitor to assure accurate counting.

Instructions for reading or sending configuration features to a High speed Counter block from the application program are given in chapter 6. The overall process of block configuration is described in more detail in the *Genius I/O System User's Manual*.

Temporary Configuration Changes

Some of the block's configuration parameters can be temporarily changed by command from the application program using the Write Data datagram. Such temporary changes are NOT displayed on a Hand-held Monitor, but can be read by the application program using a Read Data datagram. These temporary changes are not retained across a power cycle. For information about parameters that can be changed, and programming details, see chapter 6.

Configuration Steps

The following pages explain how to configure the High-speed Counter using a Hand-held Monitor (Hand-held Monitor IC660HHM501 version 3.5 or later is required). The Hand-held Monitor's Configuration Protection option must be disabled to configure a block. The block can be configured either while connected to a bus or off-line. To configure the block off-line, first complete the setup described below.

Setting up the Block for Off-line Configuration

1. Connect a 75-ohm resistor across the block's Serial 1 and Serial 2 terminals. A suitable terminator plug (IC660BLM508) is available. This resistor is provided with each Series Six PLC Bus Controller.
2. Attach a grounding strap to the ground screw on the side of the block. Connect the ground strap to earth ground.

Warning

If the block is not properly grounded, hazardous voltages may exist. Death or injury may result from contact with the block.

3. Wire the block to an appropriate AC or DC power source, as described in chapter 2.

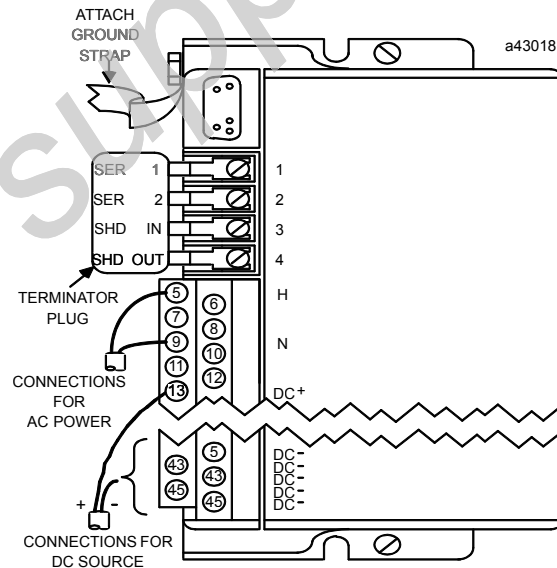

Warning

DO NOT TOUCH the connectors or wiring after powering up the block. Hazardous voltages exist, and death or injury may result.

4. Apply power to the block.

Attaching the Hand-held Monitor

If the block is on an operating bus, the Hand-held Monitor used for configuration must be the **ONLY** Hand-held Monitor currently plugged into a block on the bus.

1. Begin with the Hand-held Monitor turned OFF. Attach the Hand-held Monitor to the block.

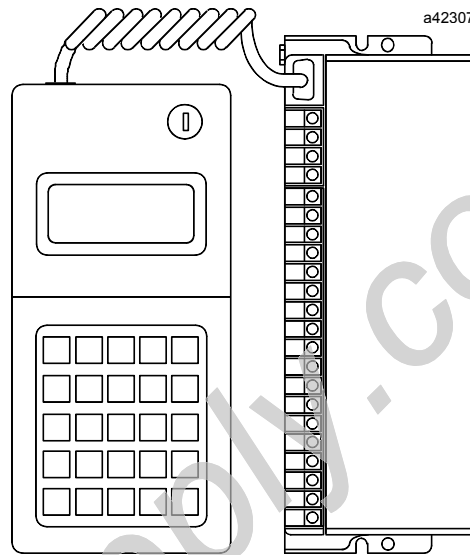

2. Turn the Hand-held Monitor on. After the HHM completes its powerup sequence, a prompt menu to verify the baud rate setting appears. Once the baud rate is verified, press F4 (OK) and the Home menu appears.
3. From the Home menu, select F3 (configuration).

HHM Configuration Menu

F 1	:	P R O G		B L O C K		I D
F 2	:	C O N F I G		B L O C K		
F 3	:	C O P Y		C O N F I G		

This is the block configuration menu, which gives you the following three choices:

PROG BLOCK ID is selected to configure the block's required features. This information must be entered using the Hand-held Monitor.

CONFIG BLOCK is selected to configure the block's optional features. These features can be entered from either the HHM or by command from the application program.

COPY CONFIG is selected to copy optional features from one block to another similar block on the same bus. See the *Genius I/O System User's Manual* for instructions to use this feature.

**Block ID,
Reference Number,
Counter Type**

From the configuration menu, select F1 (prog block ID).

A menu for entering or changing the following required parameters will appear.

HHM Display

```

P R O G   B L O C K   I D
R E F (reference number)   *
B L O C K   N O . (ID number)
r e f   b l k   e n t r   n x t

```

The Hand-held Monitor must be connected to target block for this function.

BLOCK ID: Press F2 (blk) to enter or change the block's Device Number. The menu then changes to permit the number to be entered. The Device Number is a number from 0 to 31 that represents the block's "serial bus address". The Hand-held Monitor is usually assigned ID number 0. The bus interface module is usually assigned ID number 31. Other devices are assigned numbers from 1 to 30. Each Genius I/O block is shipped from the factory with an inoperable ID number. A correct number must be assigned before the block can be configured.

Each device's ID number must be unique on a bus. The block will check to be sure its number is not assigned to another device. If it is, the block will not transmit until the ID Number is changed.

REFERENCE NUMBER: Press F1 (ref) to enter or change the block's Reference Number (required for the Series Five and Series Six PLCs only) and counter type. The menu changes to allow a number to be entered. The Reference Number is the beginning CPU reference address used by the block. The number you enter must be appropriate for the CPU.

COUNTER TYPE: On the same display, enter the block's counter type. Each type is represented here (and on the block's label) by a letter, A, B, or C:

Function	Counters	Counter Type
Unidirectionalcounters	4	A
Bidirectionalcounters	2	B
Differentialcounter	1	C

Configuration Steps

- The Hand-held Monitor must be connected to the target block. Press F2 (blk). Enter the block's ID number. Press F3 (enter).
- Press F1 (ref). The Hand-held Monitor permits selection of either I/O or register references for the block. Press F2 (tgl) to select either I/O or register memory. This entry determines where inputs and outputs used for the block will be located in the CPU. For the Series Six PLC, see chapter 5 for more information before selecting either I/O or register references for a High-speed Counter. Both selections are associated with special programming requirements.
- For the Series Five PLC, you can use either register or I/O references. If register references are used, all Genius I/O features will be available. The default counter type is type A.

Press the F2 (tgl) key to toggle the display of I/O and REG. With the correct memory type displayed, press F3 (entr). Enter the block's Reference Number. Press F3 (entr).
- On the same line of the HHM display, select the block's counter type. Press F2 (tgl) to display the letter A, B, or C. Press F3 (enter).
- Press F4 (next) to check the block's currently-assigned baud rate. Change it if necessary.

Baud Rate

The bus will not operate unless all the devices on it are set for the same baud rate. By default, the block operates at 153.6 K baud (standard).

HHM Display

```
S E L E C T   B A U D   R A T E
A C T I V E = 1 5 3 . 6 K   S T
P R O G     = 1 5 3 . 6 K   S T
           t g l   e n t r   n x t
```

Configuration Steps

1. If the baud rate should be changed, press F2 (toggle). Press F3 (enter).
2. If the baud rate is changed on any block that is currently installed on an operating bus, it must be changed on all devices on that bus. After changing the baud rate, you must cycle power at the same time to all devices on the bus to use the new baud rate.

Once the required configuration parameters have been entered, the optional selections can be changed by returning to the Configuration Menu and pressing F2 (Configure Block). From there, you can select or change other features of the block. Configuration steps are listed below in the same order in which the HHM displays will appear.

If program logic will be used to change block features, either now or in the future, see chapter 6 for the proper configuration data formats for the High-speed Counter block. Programming requirements depend on the type of PLC or host computer controlling the High-speed Counter. For more information, see the bus controller *User's Manual*.

Pulse Test

All four outputs on the block can be automatically pulse-tested at powerup. Unlike other block types, the High-speed Counter cannot be pulse-tested from the Hand-held Monitor during normal operation.

If this feature is enabled, a 0.5mS pulse is applied to each output at powerup. If the Pulse Test detects a failure, the block sends a FAILED SWITCH message. By default, the outputs are Pulse-tested at powerup.

HHM Display

```

P U L S E   T E S T
R E F (number)      (ctr type)
E N A B L E D
      t g l   e n t r   n x t
  
```

Configuration Steps

1. Pulse test is the first of the block's optional features. From the configuration menu, select F2 (config block).
2. To change the current selection, press F2 (tgl). Press F3 (enter).
3. Press F4 (next) to advance to the next configuration display.

Enable Outputs at Powerup

Following powerup, the outputs of the High-speed Counter can be either enabled or disabled. Disabling the outputs will keep them from operating before they have received the correct control information from the CPU. For the outputs to begin operation if they are disabled at startup, the CPU must send the High-speed Counter block a message which enables their operation. See chapter 5 for information about starting up disabled outputs.

If enabled automatically at powerup, the outputs will turn on and off in accordance with the relationship of the Accumulator to the ON and OFF Presets, which is the normal mode of operation. By default, the outputs are disabled following powerup.

HHM Display

```

P W R U P   O U T P U T S   E N
R E F (number)      (ctr type)
D I S A B L E D
      t g l   e n t r   n x t
  
```

Configuration Steps

1. To change the current selection, press F2 (tgl). Press F3 (enter).
2. Press F4 (next) to advance to the next configuration display.
3. If the selection on this screen is changed from a previously-used configuration, block power must be cycled for the change to become effective.

Oscillator Frequency

The High-speed Counter block generates a square wave output. This output can be used as a timing reference for measurement applications by connecting an appropriate output device to terminal 36 (marked OSC). The output frequency is determined by specifying both an oscillator frequency range selection and a divider number (N). After both have been configured, the HHM screen displays the resulting frequency selected. For a new block, the square wave output is set to operate at a frequency of 10 kHz.

HHM Display

```

O S C   F R E Q
K H Z   =   1 0 . 6 2 5 / N
D I V I D E R ( N ) =
>       t g l   e n t r   n x t

```

Configurable oscillator frequency ranges are 1360/N kHz, 170/N kHz, and 10.625/N kHz. N may be configured as any whole number from 1 – 255. The currently-selected frequency is shown as one number divided by another. For example:

170/N, with N = 17, represents a frequency of 10 kHz.

or 1360/N, with N = 5, represents a frequency of 272 kHz.

Both numbers can be changed as described below. Appendix B lists the oscillator frequencies for all combinations of kHz and N.

Configuration Steps

1. The number shown on the second line of the display can be changed to select a range within which the intended frequency is located. It may be:

5.33	to	1360 kHz (shown as 1360/N)
0.666	to	170 kHz (shown as 170/N)
0.0416	to	10.625 kHz (shown as 10.625/N)

To change this number, press F2 (tgl). Press F3 (enter).

2. Next, enter a whole number between 1 and 255 for “N”. To find this number, divide the number selected above by the intended frequency. After entering this second number, press F3 (entr). The resulting OSC output frequency is displayed on the right-hand side of line 1.
3. Press F4 (next) to advance to the next configuration display.

Control Inputs Threshold

The block accepts up to eight control inputs. These inputs, designated C1 through C8-, correspond to block terminals 26 through 33 and terminal 35. Only C8 is differential; C1-C7 are single-ended. Depending on the block's configured type, these inputs are used for:

- Preload Inputs
- Strobe Inputs
- Disable Input
- Home input
- Marker input

By default, the control inputs are organized for use with the Type A counters, and the thresholds are Non-TTL. As a group, the control inputs can be assigned to use either TTL or non-TTL level signals.

HHM Display

```

C N T L   I N P U T   T H R S H
R E F S (number)      (ctr type)
N O N - T T L
           t g l   e n t r   n x t
  
```

Configuration Steps

1. To change the threshold level, press F2 (tgl). Press F3 (enter).
2. Press F4 (next) to advance to the next configuration display.

Counter Inputs Threshold

The block has four differential counter inputs. These inputs (I1+ through I4-) correspond to terminals 16 through 23 on the block. Depending on the block's configured type, these inputs may be used for:

- Pulse inputs
- Direction inputs
- A-Quad-B inputs

The counter inputs can be assigned to either TTL or non-TTL voltage levels independently of the control inputs (see above). By default, the counter inputs are organized for use with the Type A counters, and the thresholds are non-TTL.

HHM Display

```

C T R   I N P U T   T H R S H
R E F S (number)      (ctr type)
N O N - T T L
           t g l   e n t r   n x t
  
```

Configuration Steps

1. To change the threshold level, press F2 (tgl). Press F3 (enter).
2. Press F4 (next) to advance to the next configuration display.

Strobe Linkage (Counter Type B Only)

If the block is configured for Type B counter operation, strobe inputs to Strobe Register 1 for Counter 1 and Strobe Register 1 for Counter 2 can be linked to the Count Input Pulse for Count Accumulator #2. By default, counters 1 and 2 operate independently.

If this feature is selected, each count pulse applied to Counter #2 first counts up (or down) the counter Accumulator. It then simultaneously strobos the data from Counter 1 into its Strobe Register 1, and the data for Counter 2 into its Strobe Register 1.

This feature might be used to accurately measure a pulse rate against a reference pulse (see pageA-8), or to compare two different pulse rates. The reference pulse is always connected to Counter 1 inputs and the slower rate (to be measured) is connected to Counter 2 inputs. The following illustration represents two pulses. Counter 1 pulses twelve times faster than Counter 2. Each time Counter 2 pulses, its Strobe Register 1 and Counter 1's Strobe Register 1 are loaded with their Accumulator values.

Counter 1			Counter 2		
Pulses	Accumulator	Strobe Register	Strobe Register	Accumulator	Pulses
→	1				
→	2				
→	3				
→	4				
	•				
	•				
→	12	→ 12	1 ←	1 ←	←

Input terminal connections for Strobe Input 1 for Counter 1 and Strobe input 1 for Counter 2 are not used with this feature.

HHM Display

```

S T R B E . 1 L I N K A G E
R E F S ( n u m b e r )           b
I N D E P E N D E N T
           t g l   e n t r   n x t
    
```

Configuration Steps

1. To select either INDEPENDENT (not linked) or COUPLED TO ACC2 (linked), press F2 (tgl). Press F3 (enter).
2. Press F4 (next) to advance to the next configuration display.

Select Counter

While configuring counter features for a Type A or Type B block, which have more than one counter per block, you can go directly to one of the counters from the display shown below. This display appears at the beginning of the counter configuration selections.

HHM Display

```

S E L E C T   C O U N T E R
R E F S (number)      (ctr type)
C O U N T E R   N U M =
          t g l             n x t
  
```

Configuration Steps

1. To select a counter, press F2 (tgl) to display 1, 2, 3, or 4. Select "X" to move past the counters to the final two menus, CPU Redundancy and Configuration Protect.
2. Press F4 (next) to advance to the next configuration display.

Report Faults

Each output on the block will automatically report a FAILED SWITCH diagnostics message if a fault exists on the output. This fault reporting can be disabled, so that no message will be automatically transmitted by the block if an output fault occurs. If fault reporting is disabled, the block will still detect any fault on the output. If a fault occurs while fault reporting is disabled, the block's Unit OK LED will blink and the condition can be detected and displayed on the HHM display. The fault condition must be corrected for proper operation of the block.

The application program can query the block for faults whether or not diagnostics reporting is enabled, using individual Read Diagnostic messages.

By default, all outputs report faults automatically.

HHM Display

```

R E P O R T   F A U L T S   1
R E F S (number)      (ctr type)
1 : Y E S
          t g l   e n t r   n x t
  
```

Configuration Steps

1. The screen displays the current Fault Reports selection for one output at a time. The relative number of the output (1-4) is shown in the upper right corner. If the selection is correct, press F4 (nxt) to display successive outputs on the block.
2. To change a selection, press F2 (tgl). To save the new selection, press F3, (entr).
3. Press F4 (next) to advance to the next configuration display.

Strobe Edge

Strobe Inputs are edge-sensitive. Each Strobe Input on the block can be individually configured to have either the positive or the negative edge active. By default, Strobe Inputs are positive-edge sensitive.

HHM Display

```

S T R O B E   E D G E (ctr num)
R E F S (number)      (ctr type)
1 : P O S
      t g l   e n t r   n x t

```

Configuration Steps

1. The screen displays the current Strobe Edge selection for one strobe input at a time. The number of the Strobe is shown beside the selection 'POS' or 'NEG'. The counter number is in the upper right corner.

If the selection is correct, press F4 (nxt) to display successive Strobe Inputs.

2. To change a selection, press F2 (tgl). To save the new selection, press F3 (entr).
3. Press F4 (next) to advance to the next configuration display.

Strobe Mode (Latched Strobes)

Each counter can be configured to have its strobe input(s) either latched or not latched. The default is not latched.

If a counter strobe is not latched, the Strobe Register always indicates the data from the last Strobe Input received regardless of the state of the strobe status bit in the Status byte returned.

When a counter strobe is latched, the Strobe Register always indicates the data from the first Strobe Input received after the strobe status bit is cleared. The strobe status bit is set with this first input and the Strobe Register data is not changed by additional Strobe Inputs until the Strobe status bit is cleared by the PLC.

HHM Display

```

S T R O B E   M O D E (ctr num)
R E F S (number)      (ctr type)
L A S T   ( O V E R W R I T E )
      t g l   e n t r   n x t

```

Configuration Steps

1. The screen displays the current Strobe Mode configuration: LAST for not latched, or FIRST for latched.
2. To change the current configuration, press F2 (tgl). To save the new selection, press F3 (entr).
3. Press F4 (next) to advance to the next configuration display.

Strobe Effect (Counter Type A Only)

The Strobe Input of each Type A counter can be configured as a strobe-only input, or as a combined strobe-then-preload input. The default is strobe only, in which the effect of the Strobe Input is to cause the contents of the Accumulator to be captured in the Strobe Register.

If the strobe-then-preload option is selected, when the Strobe Input occurs, the Counter Accumulator is captured in the Strobe Register, and the Accumulator is set to the configured Preload value on the same Strobe Input edge.

Combining the Preload and Strobe functions provides the Preload with additional capability:

- The counter can be preloaded on a positive OR negative edge.
- The Counts per Timebase value is not affected by Preload Inputs.

When the combined Strobe/Preload function is selected, both the Strobe and Preload status bits are set on each Strobe Input. Input signals applied to the Preload Input still operate normally, and produce only a Preload function.

HMM Display

```

S T R O B E   E F F E C T (ctr)
R E F S (number)   (ctr type)
S T R O B E   O N L Y
      t g l   e n t r   n x t
  
```

Configuration Steps

1. The screen displays the current Strobe Effect configuration: STROBE ONLY for normal Strobe operation, or STR THEN PLD for Strobe then Preload.
2. To change the current configuration, press F2 (tgl). To save the new selection, press F3 (entr).
3. Press F4 (next) to advance to the next configuration display.

Input Filters

By default, each input has a built-in high-frequency (2.5uS) filter. For the inputs listed below, this can be changed to a 12.5mS low-frequency filter (the Strobe Input always uses a high-frequency filter). The low-frequency filter reduces the effect of signal noise. Maximum count rate for the low-frequency filter is 40Hz. Input Filters apply as follows, varying by counter type.

Type A configuration (default):	Preload Input Count input
Type B configuration:	Preload Input Disable Input Count inputs
Type C configuration:	Preloads 1 and 2 Disable Input Count inputs

HHM Displays

```

D I S A B L E   F I L T E R   1
R E F S (number)   (ctr type)
H I G H   F R E Q
      t g l   e n t r   n x t
  
```

```

P R E L O A D   F I L T E R   1
R E F S (number)   (ctr type)
H I G H   F R E Q
      t g l   e n t r   n x t
  
```

```

C O U N T   F I L T E R   1
R E F S (number)   (ctr type)
H I G H   F R E Q
      t g l   e n t r   n x t
  
```

Configuration Steps

1. First the Disable Inputs filters appear (if applicable), then the Preload Input filters, then the Count Input filters. The screen displays one input filter selection at a time. For example:

```

P R E L O A D   F I L T E R   1
  
```

This indicates Preload Input 1 on a type C block, which has two Preload Inputs. If the selection is correct, press F4 (nxt) to display successive input filters for the same counter.

2. To change a selection, press F2 (tgl). To save the new selection, press F3 (entr).
3. Press F4 (next) to advance to the next configuration display. After last count input filter has been selected for the current counter.

Counter Direction

(Type A selected on the PROGRAM BLOCK ID display)

If the block is used in its Type A configuration, it provides four individual unidirectional counters. Each of the four counters can be configured to count either up or down. The default is “Up”.

HHM Display for Type A Counter

C O U N T	U P / D N	1
R E F S (number)		a
U P		
	t g l e n t r n x t	

Configuration Steps

1. The screen displays the current Up/Down selection for the current counter. The number of the counter is shown in the upper right corner.
2. To change a selection, press F2 (tgl). To save the new selection, press F3 (entr).
3. Press F4 (next) to advance to the next configuration display.

Counter Signal Mode

For a Type B or Type C block configuration, select how each counter will be used:

in Up/Down mode, or
in Pulse/Direction mode, or
in A-Quad-B mode

HHM Display

C	O	U	N	T	S	I	G	N	A	L	S	1			
R	E	F	S	(n	u	m	b	e)	c				
P	U	L	S	E	/	D	I	R							
					t	g	l	e	n	t	r	n	e	x	t

Configuration Steps

1. The selection shown on line 3 may be:

P U L S E / D I R [1c1/2]

for Pulse/Direction mode, this is the default. In this mode, the counter counts pulses on I1 and senses the direction signal on I2.

U P / D N [1c1/2]

for Up/Down mode. In this mode, the counter counts up pulses on I1 and down pulses on I2.

A Q U A D B [1c1/2]

for A-Quad-B mode. In this mode, the counter counts A-quadrature signals on I1 and B-quadrature signals on I2.

2. To change the Count Signal selection, press F2 (tgl). To save the new selection, press F3 (entr).
3. Press F4 (next) to advance to the next configuration display.

Continuous or Single-Shot Counting

Each counter on a block has programmable count limits that define its range. The counter can either count continuously within these limits, or count to either limit, then stop.

Continuous Counting

In the continuous counting mode, if either the upper or lower limit is exceeded, the counter “wraps around” to the other limit and continues counting. Continuous counting is the default mode.

Single-shot Counting

If “single-shot” is selected, the counter will count to its upper or lower limit, then stop. When a Preload Input is applied, or if the Accumulator is loaded by the application program, the counter repeats the cycle. When the counter is at the limit, counts in the opposite direction will count it back off the limit.

HMM Display

C	O	U	N	T		M	O	D	E		1							
R	E	F	S		(number)		(ctr		type)									
C	O	N	T	I	N	U	O	U	S									
						t	g	l		e	n	t	r		n	e	x	t

Configuration Steps

1. The screen displays the current Count Mode selection for the counter displayed in the upper right corner.
2. To change a selection, press F2 (tgl). To save the new selection, press F3 (entr).
3. Press F4 (next) to advance to the next configuration display.

Counter Timebase

For each counter, the timebase represents a span of time which can be used to measure the rate of counting. For example, the program might need to monitor the number of count pulses which are occurring every 30 seconds.

A timebase from 1mS to 65535mS can be selected for each counter. The block stores the number of counts that occurred during the last-completed timebase interval. This count value can be displayed using the Hand-held Monitor (as described in chapter 4). This data is also available to the application program, as described in chapter 6. The counter timebase is set to 1 second (1000 mS) by default.

HHM Display

```

T I M E   B A S E           1
R E F S (number)         (ctr type)
      (timebase in mS)
c h n g                   n x t

```

Configuration Steps

1. The number of the counter is shown in the upper right corner.
2. To enter or change the timebase, press F2 (chng). The current value is replaced with the entry cursor (_) and the function of the F3 key becomes (entr).
3. Enter the new value from the HHM keypad and press F3 (entr).
4. Press F4 (next) to advance to the next configuration display.

Count Limits

Each counter can be assigned upper and lower count limits. All Accumulator preload values and output on/off Preset values must lie within these limits. The upper (high) limit is the most positive, and the lower limit is the most negative. Both can be positive, or both can be negative, but the high limit must be greater than the low limit. Specifying a low limit that is higher than a high limit causes the block to set the error status bit and indicate a Counter Configuration error in the Status Code input byte.

For Type A (16-bit) counters, the limit values must fall between -32,768 and +32,767.

For Type B and C (24-bit) counters, the limit values must fall between -8,388,608 and +8,388,607.

HHM Display

C	O	U	N	T	L	I	M	I	T	S	1
H	I	G	H	_____							
L	O	W	_____								
>	c h n g							n x t			

Configuration Steps

1. The number of the counter is shown in the upper right corner.
2. To select either HIGH or LOW, press F1 (1). To enter or change the Count Limit, press F2 (chng). The current value is replaced with the entry cursor (_) and the function of the F3 key becomes (entr).
3. Enter the new value from the HHM keypad and press F3 (entr).
4. Press F4 (next) to advance to the next configuration display.

Changing Count Limits

To avoid error messages when changing previously-configured Count Limits with a Hand-held Monitor:

- Move the High Limit first when shifting the limits *up*.
- Move the Low Limit first when shifting the limits *down*.

Output Presets

Each counter output has a On Preset and an OFF Preset. The output state indicates when the counter Accumulator value is between the ON and OFF points.

Preset closest to low limit	Output ON	Output OFF
ON	$> = \text{ON Preset}$ $< = \text{OFF Preset}$	$> \text{OFF Preset}$ $< \text{ON Preset}$
OFF	$< \text{OFF Preset}$ $> \text{ON Preset}$	$< = \text{ON Preset}$ $> = \text{OFF Preset}$

The output may be either on or off when the Accumulator value lies between the Preset points.

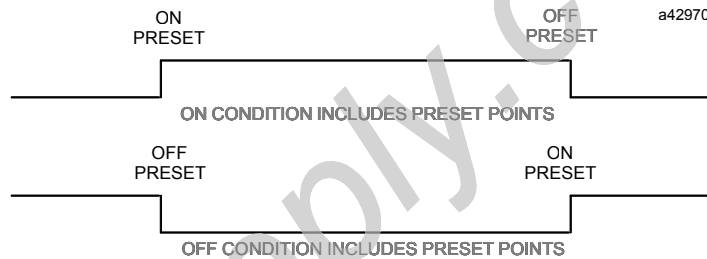

For example:

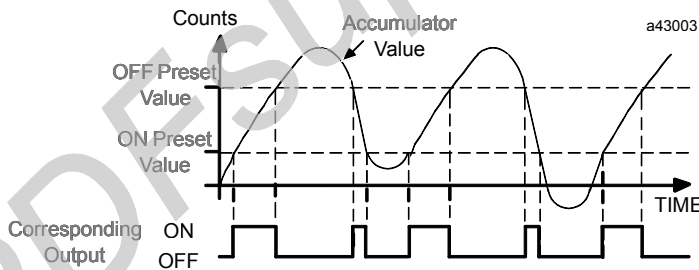

Location of Preset Points

The Preset points may be located anywhere within the counter range. When the accumulator value is between the Preset points, the output ON/OFF state will always be that of the lowest (most negative) Preset point. When the accumulator value is *not* between the Preset points, the output ON/OFF state will be that of the most positive Preset. This is true regardless of the counter direction.

The following example shows the output state in the range of Accumulator values of a 2-byte counter, when the Off Preset is less than the On Preset.

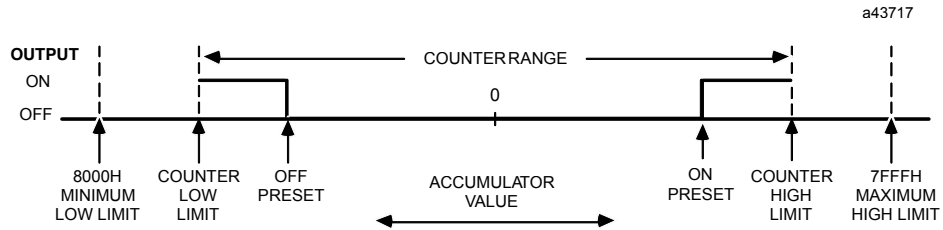

If both Preset points are within the counter range, the output always switches at the Preset points.

If the On/Off Preset points are equal and within the counter range, the output will be ON ONLY when the Accumulator is at the Preset point.

If only one of the Preset points is programmed within the counter range, then the counter limits will function as the other Preset point in the continuous mode. The output will switch when wraparound occurs.

If neither of the Preset points is in the counter range, then the output state will not change; it will always be the state of the most positive Preset. If both Preset points are equal and out of range, the output will always be OFF.

Separation of Preset Points

The count Accumulators are compared to the Presets at 0.5mS intervals. Therefore, to guarantee that the outputs will always switch, the Preset points must be separated by at least the number of counts received in a 0.5mS time period. For example:

If maximum count rate = 10kHz, then minimum count separation = 5 counts

HHM Display

P	R	E	S	E	T	1		
O	N	1	:	_____				
O	F	F	1	:	_____			
>		c	h	n	g	n	x	t

Configuration Steps

1. The number of the counter is shown in the upper right corner. Some counters have more than one set of Presets for each counter. The number of the Preset pair appears on lines 2 and 3.
2. To select either ON or OFF press F1 (>). To enter or change the Output Preset, press F2 (chng). The current value is replaced with the entry cursor (_) and the function of the F3 key becomes (entr).
3. Enter the new value from the HHM keypad, and press F3 (entr).
4. Press F4 (next) to advance to the next configuration display. For counters with more than one Preset pair, F4 selects the next pair.

Home Position

If the block has been set up to operate as a Type C counter, a Home position can be selected. The default is 0. The counter will be set to this value when all three of the following occur in this sequence:

1. The Home command is given by the CPU (output bit 13).
2. The Home Limit Switch input is present (indicated by input status bit 7).
3. The next Marker input pulse occurs.

Once the Home Value has been inserted into the counter, the Home Found status bit is set (input status bit 3). It indicates to the CPU that the Home Command can now be removed (cleared). If the CPU clears the Home command before the Home Found is indicated, a Home Error will result.

HHM Display (for Type C Configuration)

HOME POSITION	
REFS (number)	c
(home count value)	
chng	next

Configuration Steps

1. To enter or change the Home position value, press F2 (chng). The current value is replaced with the entry cursor (_) and the function of the F3 key becomes (entr).
2. Enter the new value from the HHM keypad, and press F3 (entr).
3. Press F4 (next) to advance to the next configuration display.

Preload Accumulator Value

For each counter, a reset value for the Accumulator (which contains the current count value) can be specified. If the counter should be reset to 0, enter 0 as the Preload value (this is the default). For a differential (type C) counter block, two different Preload values can be selected for the same counter.

During system operation, if the counter's Preload Input occurs, the Accumulator will be reset to this configured Preload value. The block will notify the host that the Accumulator has been reset by setting the corresponding Preload Status bit to 1. The application program should monitor the block's status bits, and if a Preload Status bit has been set to 1, the corresponding Reset Preload bit should be used to reset it.

For Type A (16-bit) counters, the Preload range is $-32,768$ to $+32,767$.

For Type B or C (24-bit) counters, the Preload range is $-8,388,608$ to $+8,388,607$.

The value entered here will be stored in the corresponding Preload Register.

HHM Display

```

P R E L O A D   V A L U E
R E F S (number)   (ctr type)
                   (preload count value)
c h n g           n x t
  
```

Configuration Steps

1. To enter or change the Preload value, press F2 (chng). The current value is replaced with the entry cursor (_) and the function of the F3 key becomes (entr).
2. Enter the new value from the HHM keypad, and press F3 (entr). For a type C counter (the letter C appears at the right side of line 2), two different Preload values can be entered.
3. Press F4 (next). The "Select Counter" menu will reappear, and a new counter number may be selected. The configurable parameters for the new counter can be entered as described on the previous pages. After configuring all counters, select "X" to advance to the CPU Redundancy menu.

CPU Redundancy

If it will be used on the same bus with two controllers (PLCs or host computers), each of which is sending outputs to blocks on the bus, the High-speed Counter must be set up for CPU redundancy. For a new High-speed Counter as shipped from the factory, this feature is not enabled.

If selected, the High-speed Counter can operate in what is called “Hot Standby mode”. In Hot Standby mode, the block receives output data from both CPUs, but uses the data from only one of them. The block prefers output data sent by the bus interface module (Bus Controller or PCIM) with Device Number 31. If this data is not available, the block will use output data from the bus interface module with Device Number 30.

HHM Display

```

C P U   R E D U N D A N C Y
R E F S (number)   (ctr type)
N O   C N T L   R E D U N D
           t g l   e n t r   n x t
  
```

Configuration Steps

1. To change the current selection, press F2 (tgl). Press F3 (entr) to save the new selection.
2. Press F4 (next) to advance to the next configuration display.

Configuration Protection

This feature can be used to protect the block’s configuration, preventing changes from the CPU or Hand-held Monitor. It can only be selected from the Hand-held Monitor. To make subsequent changes, protection must be removed again using the Hand-held Monitor. (To enable or disable configuration protection, the Hand-held Monitor keyswitch must be in its CFG position.) For a new block, configuration is unprotected. Before a block is used in the system, its configuration should be protected.

HHM Display

```

C O N F I G   P R O T E C T
R E F S (number)   (ctr type)
D I S A B L E D
           t g l   e n t r   n x t
  
```

Configuration Steps

1. To change the current selection, press F2 (tgl). Press F3 (entr) to save the new selection.
2. Press F4 (next) to advance to the first configuration display.

Chapter 4

Monitoring Operation of the High-Speed Counter

This chapter shows how to use the Hand-held Monitor to:

- Display each output's current state.
- Display the current status of the block's control inputs (Preload, Strobe, Disable, Home).
- Display the current values in the data storage registers (Accumulator, Counts per Timebase, Strobe) for each counter.
- Display the fault status of an output.
- Force outputs either ON or OFF, or release a force.

Using the Hand-Held Monitor

All the functions described in this chapter can be done with the Hand-held Monitor attached directly to the High-speed Counter block, or attached at any other location on the same bus. Follow the instructions below to attach the Hand-held Monitor, and to make the High-speed Counter the "active" device on the Hand-held Monitor display.

If the Hand-held Monitor is already attached to the bus, it is not necessary to move it. See "Select the High-speed Counter" below. The Hand-held Monitor should be off when you attach it to another device or connector on the bus. Then turn it on by pressing the ON/OFF key. The first display that appears is the baud rate selection screen:

HHM Display

```
HHM BAUD RATE
ACTIVE = 153.6K ST
MUST MATCH BUS
      c h n g           o k
```

← HHM baud rate

All devices on a bus must use the same baud rate. If the Hand-held Monitor has just been operated on the same bus, the baud rate shown should be correct. If it is, press F4

(okay) to display the Home menu. If the baud rate is not correct, press F2 (chng). A new screen will appear where you can select the baud rate by pressing the F2 (tgl) key. After selecting the baud rate, press F3 (entr). Then press F4 (ok) to return to the screen shown above.

Menus on the Hand-held Monitor

From the HHM Home menu, select the Analyze functions to monitor operation of the block

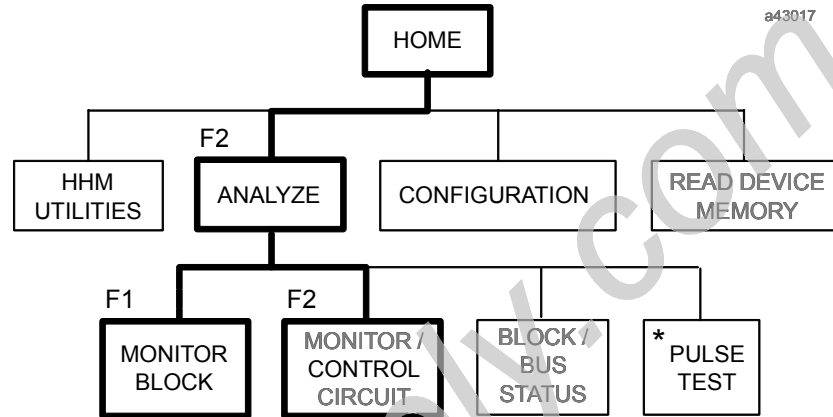

* The High-speed Counter block can be configured to have its outputs pulse-tested automatically when it powers up (see Chapter 3). It cannot be pulse-tested using the Hand-held Monitor.

Select the High-Speed Counter

1. From the Home menu, press F2 (analyze).
2. From the Analyze menu, select F3 (block/bus status). The Hand-held Monitor shows the status of the active device:

HHM Display

```

REF (number) (counter type)
H S C T R (version) A C T ← active device, Device Number
N O F O R C E , N O F A U L ← present status
n x t p r v a c t v b u s
  
```

3. If the active device indicated on line 2 is not the High-speed Counter block, press F1 (nxt) or F2 (prev) as needed to locate it.
4. If there is more than one High-speed Counter on the bus, use the information displayed on line 1 (reference number and counter type) to identify them. When the correct device's information is displayed, press F3 (actv) to make it the active block.

Display Preset Output States

Procedure

- From the Home menu, select F2 (analyze).
- Select F1 (Monitor Block).

HHM Display

R E F		(number)	(counter type)	
P R E S E T				O U T P U T S
1	2	3	4	
0	0	0	0	n x t

← output number
← present output state

REF (number) is the beginning reference address used by the block. (Counter type) is a letter indicating how the block is set up:

- A: the block has four counters. Each output is controlled by a separate counter.
- B: the block has two counters. The first counter controls outputs 1 and 2; the second counter controls outputs 3 and 4.
- C: the block has one counter that controls all four outputs.

The third line (1 2 3 4) represents the four outputs on the block:

- 1: output O1, which corresponds to terminal 38.
- 2: output O2, corresponds to terminal 39.
- 3: output O3, corresponds to terminal 40.
- 4: output O4, corresponds to terminal 41

(input state) the bottom line displays each Preset output's current OFF (0) or ON (1) state. An underline indicates that the output is forced to the state being displayed. When an output is forced, it cannot change and does not respond to the actual value of the counter. See "Force Outputs" for information.

Display Control Input States

- Preload Inputs
- Strobe Inputs
- Disable Input
- Home Input

Procedure

- From the Home menu, select F2 (analyze).
- Select F1 (Monitor Block). The Hand-held Monitor displays the block's output states.
- From the outputs display, press F4 (next).

HHM Displays *Block configures as Type A:*

C O N T R O L I N P U T S							a	← block type
1	2	3	4	1	2	3	4	← input number
P	P	P	P	S	S	S	S	← input type
0	0	0	0	0	0	0	0	← input state

Block configures as Type B:

C O N T R O L I N P U T S							b	← block type
1	2	1	2	1		2		← input number
D	D	P	P	S	S	S	S	← input type
0	0	0	0	0	0	0	0	← input state

Block configures as Type C:

C O N T R O L I N P U T S							c	← block type
1	1	1	2	1	2	3		← input number
D	H	P	P	S	S	S		← input type
0	0	0	0	0	0	0		← input state

Description of Display Lines

The letter A, B, or C at the right side of the top line represents the block's counter configuration.

(input number) the second line identifies the first, second, third, or fourth control input of the same type on the block. For example:

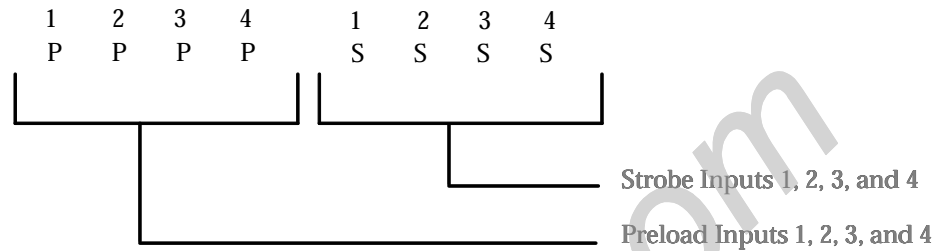

(input type) the third line represents the control input type, as follows:

- D: Disable Input
- H: Home Input
- P: Preload Input
- S: Strobe Input

(input state) the bottom line displays each control input's current OFF (0) or ON (1) state.

Disable and Home inputs are level-sensitive and therefore this state indicates the present state of the switch input.

Preload and Strobe Inputs are edge-sensitive and this state indicates the Strobe/Preload status bit returned to the CPU. If a CPU is online, it will normally set this back to "0" immediately each time a "1" is sensed.

Display Current Values

- Accumulator
- Counts per Timebase
- Strobe

Procedure

1. From the Home menu, select F2 (analyze).
2. Select F1 (Monitor Block). The Hand-held Monitor displays the block's output states.
3. From the outputs display, press F4 (next) twice. The HHM displays the current values in the Accumulator and Counts per Timebase values for the block's first counter, as illustrated below.
4. From either of these displays, press F4 (nxt) to read the Accumulator, Counts per Timebase, and Strobe values for other counters on the same block.

HHM Display

R E F	(number)	(counter type)	
A C C	1 :	"	_____
C T B	1 :	"	_____
>			n x t

← Accumulator value
← Counts/Timebase

REF (number) is the beginning reference address used by the block. The letter A, B, or C at the right side of the top line represents the block's counter configuration.

Lines 2 and 3 show the current values of the Accumulator and Counts per Timebase currently stored for that counter. Counts per Timebase represents the number of count inputs that have occurred within the last complete selected time interval. Both are signed.

Press F1 (>) for:

R E F	(number)	a
S T R	1 :	" _____
>		n x t

← Strobe value

Display/Clear Output Faults

The Hand-held Monitor will show if any output on the block has a fault.

1. From the Home menu, select F2 (analyze).
2. Select F2 (Monitor/Control Reference). The Hand-held Monitor displays the current state and the fault status of the first output on the block.
3. From the status display, press F1 (>) to read the state and fault status of other outputs on the same block.

HHM Display

```

M N T R / C N T L (ref)   (type)
S T A T E :
N O F A U L T S
>   o n   o f f   r e l e s
  
```

← current state
← fault status

(Ref) is the reference address used for the block's output status bits. The block uses a total of 256 input reference bits (16 words). The status bits occupy the last data word. Therefore, if the block were assigned Reference Number 1, its output status bits would begin at Reference Number 249.

The letter A, B, or C at the right side of the top line represents the block's counter configuration.

Line 2 shows the current state of the output. An underline shows that the output is forced to the state being displayed. When an output is forced, it cannot change and does not respond to the actual value of the counter. See "Force Outputs" for information.

If the output has a fault, line 3 displays:

F A I L E D S W I T C H

To clear a fault:

To clear an output fault, press the CLEAR key on the Hand-held Monitor. (If the fault message reappears for the same output, the condition that caused the message must be corrected).

Display/Force Output States

Each output on the High-speed Counter block can be “forced” to be either on or off using the Hand-held Monitor. When an output is forced, it cannot change and does not respond to the actual value of the counter. An output will remain forced through a power cycle. The force must be removed by the Hand-held Monitor.

In addition to being displayed on the Monitor/Control Block screen (see below), forced outputs are also indicated on the block status screen:

R E F (number) (counter type)
H S C T R (version) A C T
N O F O R C E, N O F A U L
n x t p r v a c t v b u s

← active device

← status

and on the Monitor Block screen:

R E F (number) (counter type)
1 2 3 4
o o o o
o o <u>1</u> o

← output number

← output state (underlined)

Force or Unforce Outputs

Procedure

1. From the Home menu, select F2 (analyze).
2. Select F2 (Monitor/Control Reference).

HHM Display

```
M N T R / C N T L (ref) (type)
S T A T E :
N O F A U L T S
> o n o f f r e l e s
```

← current state
← fault status

Line 2 shows the current state (0 or 1) of the first output on the block. If the output is currently forced, an underline appears below the output state. For example, this output is forced ON:

```
S T A T E : 1
```

To read the output status of another output on the same block, press F1 (>).

Force an Output

To force an output, press F2 (on) or F3 (off). The block's I/O Enabled LED #2 blinks whenever an output is forced.

Remove a Force

To remove a force, press F4 (reles).

Chapter 5

Input and Output Data

In this chapter, you will find:

- Information about how different types of host handle the input and output data of a High-speed Counter block.
- Descriptions of the data routinely transferred to and from a High-speed Counter block.

Overview

Input and output data are the data routinely transferred between a block and its host PLC or computer.

For most Genius I/O blocks, input and output data correspond to the hardware inputs and outputs connected to the block. However, for a High-speed Counter block, that is not the case. For a High-speed Counter, the input data informs the host about the operation of the block, and the output data can be used by the host to send instructions to the block.

Nearly all interaction between the host and the High-speed Counter block takes place through this input and output data. The host can also communicate with a High-speed Counter using datagrams. That type of interaction between the block and its host is described in the next chapter.

Input Data from a High-speed Counter

Each bus scan, the High-speed Counter block sends 16 words of input data on the bus. It consists of 15 words of word-oriented data, such as the current accumulator values, followed by one word of bit-oriented data containing status information. The format and content of the input data sent by the High-speed Counter depends on whether the block has been configured for Type A, Type B, or Type C operation. Data formats for each type are shown in this chapter.

How input data from a High-speed Counter block is handled by its host PLC or computer depends on the host type, as explained under “Programming Considerations”, beginning on the next page.

Output Data from the Host

Each bus scan, the host PLC or computer's bus controller directs 1 word of bit-type data to a High-speed Counter.

The host can set individual output bits to enable any or all of the block's outputs and to reset status input bits.

For a block configured for type C operation, output bits can also be used in conjunction with the Home command.

The Relationship Between Status Inputs and Output Bits

As mentioned above, the last word of each input message sent by the block consists of status bits. The application program should monitor the status bits, and use the corresponding output bits to reset them as necessary. Specific status bits and output bits are described later in this chapter.

PDFSupply.com

How the Host Handles High-speed Counter Inputs and Outputs

Although input and output data formats for a High-speed Counter block are somewhat different in its Type A, Type B, and Type C configuration, these three data formats are always consistent, regardless of the type of PLC or computer being used as the host. However, the block's input and output data are not handled the same way by all hosts. The next few pages explain how different kinds of host handle High-speed Counter data.

Because of the amount of data transmitted and the large number of reference addresses occupied by a High-speed Counter block, special block placement and programming consideration are necessary for some applications.

Series 90-70 PLC

When a High-speed Counter block is configured using Logimaster 90, it is assigned *three* memory locations (in %I, %Q, and %AI memories) for its 16 bits of input data, 16 bits of output data, and 15 words of calculated data. For example, if a High-speed Counter block were configured to use Reference Address 0049, the following memory locations would be reserved for the block:

%I0049 to %I0064	for the block's inputs
%Q0049 to %Q0064	for the block's outputs
%AI0049 to %AI0063	for the block's calculated data

Input Data Formats

As the data formats in this chapter show, the block first sends 15 words of %AI data, followed in the same message by one word of %I data.

While the exact content of the block's input data depends on the block's configured type (A, B, or C), the basic arrangement of data is the same. The %AI data contains the counts per timebase, accumulator, strobed, and other word-type data for the block.

The %I data contains status information that can be monitored by the application program. This status data includes output status, strobe status, module ready status and preload status. It may also include disable status and Home input status, depending on the configured block type.

Series Six PLC

Because of the large amount of data it sends to the CPU each bus scan, many applications will require special programming for a High-speed Counter.

Number of High-speed Counter Blocks on a Bus

One High-speed Counter block requires 256 inputs. Therefore, a Bus Controller with Diagnostics (IC660CBB902) can only accommodate enough I/O references for three High-speed Counter blocks. A Bus Controller without Diagnostics (IC660CBB903) can accommodate four. *If the application does not require any diagnostic reports from a High-speed Counter block (see below), this limitation can be overcome by assigning the block to register memory instead of I/O memory. This would potentially allow up to 30 High-speed Counter blocks to be controlled by the same Bus Controller.*

Organization of High-speed Counter Data in Series Six Memory

A High-speed Counter block always sends 16 words (32 bytes) of input data each time it receives the communications token on the bus. If the block is assigned to I/O memory in the Series Six, the data will occupy 256 inputs in the Input Table. The first 240 inputs will contain the block's word-type data. Inputs 241 to 256 will contain the block's 16 status bits. Outputs for the block will occupy 16 outputs in the Output Table.

If the block is assigned to register memory instead of the I/O Table, the data will occupy 17 registers: 15 registers of word-type inputs, then 1 register of status bits, then 1 word of output bits.

Programming for High-speed Counter Blocks Assigned to I/O Memory

The Bus Controller handles inputs from High-speed Counters, PowerTRAC blocks, and all types of analog blocks (including RTD and Thermocouple blocks) differently from discrete block inputs, which are updated during the normal I/O scan. Each CPU sweep, the Bus Controller begins internally organizing input data from High-speed Counter and analog blocks at the start of the PLC's programmer window. This continues until all the data has been organized. Normally, the programmer window time available to move this data is 0.311mS. However, the time required to organize the inputs from one High-speed Counter block is 0.422mS. Whenever there is a High-speed Counter block on the bus, data organization will extend past the time allotted to the programmer window and into the beginning of the logic execution portion of the sweep.

To avoid read/write conflicts while the Bus Controller is organizing data, it is important to be sure that the CPU does not attempt to read this data too soon. If there is no DO I/O instruction at the beginning of the program, or if program execution takes up enough time, there may not be a conflict. If there is a DO I/O instruction to the Bus Controller early in the program, or if the program is very short (resulting in the normal I/O scan beginning soon after the programmed window ends, the programmer window time should be extended. This can be done by adding one of the following commands to the program before any I/O update (either normal I/O update or DO I/O instructions):

- to extend the programmer window by 1.2mS, direct an idle DPREQ or WINDOW instruction to the Bus Controller.
- to extend the programmer window by 5mS, program a DPREQ or WINDOW instruction with no Bus Controller address.

To find the total time needed to update inputs, find the contributions of all analog blocks (of any type) and High-speed Counters and all PowerTRAC blocks on the bus.

Using the Read Analog Inputs Command

Another way to update input data from a High-speed Counter block assigned to I/O memory is by programming a Read Analog Inputs command and ignoring the normal input data. This command can be used to read values directly from the Bus Controller's own RAM memory (not from its "shared" RAM). This area of memory always contains the latest values from each High-speed Counter block (and analog block). If the program is required to have the latest values of these inputs as the logic executes, a Read Analog Inputs command should be used instead of a DO I/O instruction. DO I/O reads input values from shared RAM. Since the Bus Controller updates shared RAM only once per CPU sweep, multiple DO I/O instructions in the same program sweep would return the same values each time.

Programming for High-speed Counter Blocks Assigned to Register Memory

To use additional High-speed Counter blocks on a bus, it is possible to assign them to register addresses, rather than I/O addresses. However, if this is done:

1. Automatic I/O updates are NOT performed. References in register memory are NOT updated during the I/O scan portion of the sweep. A window must be opened (using a DPREQ or WINDOW instruction at the beginning of the sweep) to update I/O points assigned to register memory. An "Idle" DPREQ or WINDOW instruction can be used.
2. Automatic diagnostics (Failed Switch, Addition of Block, Loss of Block, Address Conflict) are not available. If the Failed Switch message is needed from a block with a register reference, a Receive Datagram command must be used to send a Read Diagnostics Datagram to the block. (Since the block is assigned to register memory, the Read Diagnostics command cannot be used. Use Receive Datagram instead.)
3. Similarly, to read or write configuration data from a block assigned to register memory, the program must include a Send Datagram or Receive Datagram command to transmit the appropriate Datagram.

Series Five PLC

Each bus scan, the Series Five Bus Controller receives 32 bytes (16 registers) of data from a High-speed Counter block. This data is automatically transmitted from the Bus Controller to the CPU during the I/O portion of the CPU sweep. The CPU places the data into I/O or register memory beginning at the reference address assigned to the block.

Because one High-speed Counter block requires 256 inputs, one block occupies 12% of the available I/O memory space. This potential limitation on I/O use can be avoided by assigning the High-speed Counter blocks to register (global) memory instead of I/O memory. If the High-speed Counter is assigned to register memory, its data will occupy 17 registers--16 registers of "input" data from the HSC to the CPU, followed by 1 register of "output" commands from the CPU to the HSC.

Genius I/O diagnostics will be performed normally by the Series Five PLC in either case. The restrictions which apply to Series Six applications do not apply to Series Five applications.

Organization of High-speed Counter Data in Series Five Memory

A High-speed Counter block always sends 16 words (32 bytes) of input data each time it receives the communications token on the bus. If the block is assigned to I/O memory in the Series Five, the data will occupy 256 inputs in the Input Table. The first 240 inputs will contain the block's word-type data. Inputs 241 to 256 will contain the block's 16 status bits. Outputs for the block will occupy 16 outputs in the Output Table.

If the block is assigned to register memory instead of the I/O Table, the data will occupy 17 registers: 15 registers of word-type inputs, then 1 register of status bits, then 1 word of output bits.

Host Computer

Each bus scan, the Personal Computer Interface Module (PCIM) receives 32 bytes (16 words) of data from a High-speed Counter block. This data is stored in a 128-byte area of shared RAM on the PCIM. The application program can overlay a data structure, suited to the counter type configured, on this data, distinguishing its individual elements.

I/O Data: Block Configured as Type A

This input word is only meaningful if the most significant bit of the status word (word 16) has been set to 1 by the block. This word shows which counter has the limit configuration error. Enter compatible limits to clear the error.

Input Data

Words 1 through 15 are word data (words 14 and 15 are not used for the Type A block configuration). Word 16 is bit data.

Word No.	Description
1	Status code
2	Counts per timebase for counter 1 (LSB in byte 2)
3	Counts per timebase for counter 2
4	Counts per timebase for counter 3
5	Counts per timebase for counter 4
6	Accumulator for counter 1
7	Strobe Register for counter 1
8	Accumulator for counter 2
9	Strobe Register for counter 2
10	Accumulator for counter 3
11	Strobe Register for counter 3
12	Accumulator for counter 4
13	Strobe Register for counter 4
14, 15	Not used (set to 0)
16	Statusbits

Status Code This input word is only meaningful if the most significant bit of the status word (word 16) has been set to 1 by the block. This word shows which counter has the limit configuration error. Enter compatible limits to clear the error.

Status Code		Error Indication
decimal	hex	
11	0B	Counter 1 Limit Configuration error
12	0C	Counter 2 Limit Configuration error
13	0D	Counter 3 Limit Configuration error
14	0E	Counter 4 Limit Configuration error

Counts per Timebase The number of counts that have occurred within the timebase (1mS to 65535mS) configured for counters 1, 2, 3, and 4.

Accumulators The Accumulators for counters 1, 2, 3, and 4 contain their current count values. Count limits are -32,768 to +32,767, but different limits may have been selected by configuration. If the counter has been configured for continuous counting mode, the accumulator value will wrap around if either limit is reached.

If the counter has been configured for single-shot counting mode, it counts to either limit then stops. If the counter's Preload Input is applied or the Accumulator is loaded from the CPU, the counter repeats

the cycle. When the counter is at the limit, counts in the opposite direction will back it off the limit.

If the counter's Strobe Input and Preload Input go active in the same 0.5mS interval, the block sets both the Accumulator and the Strobe Register for that counter to the value in the counter's Preload Register.

Strobe Registers

When a counter's Strobe Input goes active, its current Accumulator value is copied to its Strobe Register and a status bit is set to 1 (see Status Bits, below) to inform the CPU that a strobed value has been captured. The strobed value remains in the Strobe Register until the Strobe Input goes active again, at which time it is overwritten.

If the Latched Strobe mode has been configured, subsequent strobe inputs will not overwrite the first strobe data until the Strobe status bit has been cleared by the CPU. In this mode, each time the CPU acknowledges receipt of the Strobe status bit, the application program should clear it.

If the counter's Strobe Input and Preload Input go active in the same 0.5mS interval, the block sets both its Accumulator and Strobe Register to the value in the Preload Register.

If the counter's Strobe Input has been configured to produce both the Strobe function and the Preload function on the same signal edge, the Strobe Register is set to the Accumulator value before the Accumulator is set to the Preload value.

Status Bits

Word 16 of the input data sent by a Type A block contains the following status information.

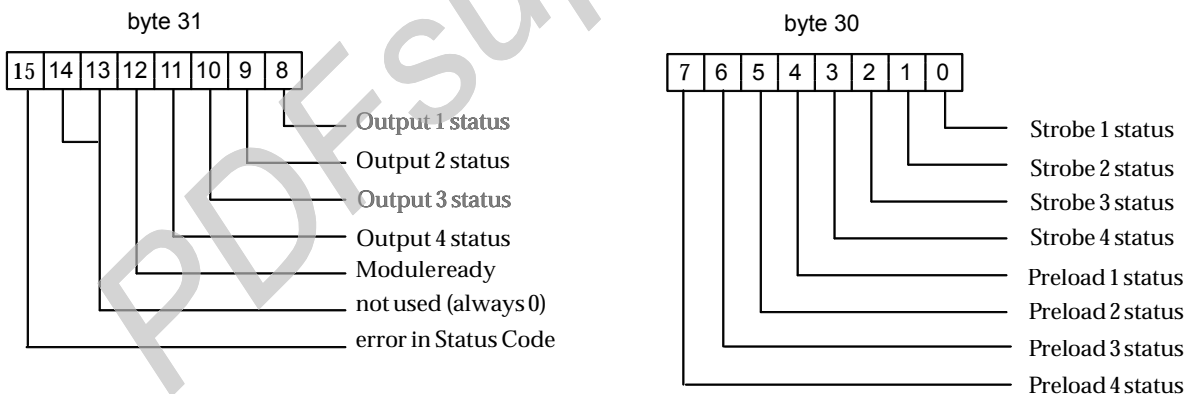

Strobe and Preload Status

the block sets one of these bits when a strobe or preload occurs. The CPU must clear the bit using the corresponding Reset Strobe or Reset Preload output (see next page).

Output Status

the block uses these four bits to indicate the ON or OFF status of each output.

Module Ready the block sets this bit to 1 after successfully completing its powerup tests. After powerup, the block sets the Module Ready status to 0 if any of the following occurs:

1. a failed switch condition on a Counter output.
2. the block is reconfigured. Sending new configuration data to the block causes the block to remove the Module Ready momentarily while the non-volatile memory is updated. After completing the configuration update, the block sets this bit to 1.
3. the block receives a Begin Packet Sequence message from another device. When the End Packet Sequence message is received or 10 seconds have elapsed, the block sets the Module Ready bit to 1.

Error if this bit is 1, there is a count limit configuration error; the High limit is currently configured to be LOWER than the Low limit. To identify the counter with the configuration error, read the value in the first input word (described previously).

Output Data: Block Configured as Type A

Once each bus scan, the host bus controller sends one word (two bytes) of data to the block. By setting and clearing these bits, the host application program can send one command per bus scan to the block. For a block configured as Type A, these outputs have the following definitions.

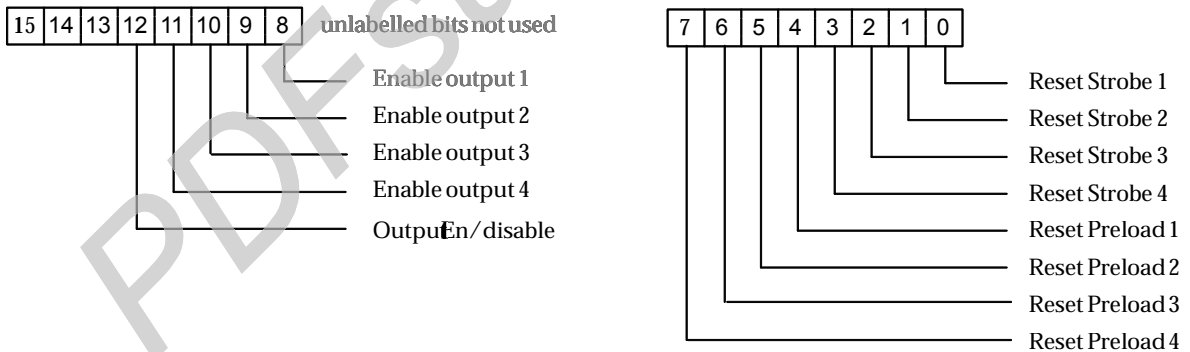

Reset Strobe clears the block's corresponding Strobe input status bit (as described on the previous page). For example, Reset Strobe bit #2 is used to reset the block's Strobe status bit #2. If the corresponding Strobe Input status changes to 1, the program logic should set this bit to 1 (for at least one Genius bus scan) to clear the Strobe Input status bit and then back to 0.

Reset Preload clears the block's corresponding Preload input status bit. If the corresponding Preload Input status changes to 1, the program logic should set the reset bit to 1 and then back to 0 the next bus scan.

Enabled Output (#) bits 8 to 11 are used in conjunction with bit 12 to selectively enable or disable the block's outputs.

If the block's configuration has been set up so that outputs are *disabled* when the block is powered up, these bits should then be used to turn them on.

During operation, if an output is already on and the host disables it using its output bit, the output will go off and stay off until it is re-enabled.

Outputs Enable/Disable if this bit is 1, bits 8 to 11 are effective. If it is 0, bit 8 to 11 are not effective.

I/O Data: Block Configured as Type B

Input Data

Words 1 through 15 are word data. As the next table shows, each of the values in words 4 through 15 is a double word. Word 16 is bit data.

Word No.	Description
1	Status code
2	Counts per timebase for counter 1
3	Counts per timebase for counter 2
4, 5	Accumulator for counter 1 (LSW in word 4, MSW in word 5)
6, 7	Strobe Register 1 for counter 1
8, 9	Strobe Register 2 for counter 1
10, 11	Accumulator for counter 2
12, 13	Strobe Register 1 for counter 2
14, 15	Strobe Register for counter 2
16	Statusbits

Status Code This input word is only meaningful if the most significant bit of the status word (word 16) has been set to 1 by the block. The status code indicates which counter has a counter limit configuration error; its high limit is currently configured to be LOWER than the low limit. Enter compatible limits to clear the error.

Status Code		Error Indication
decimal	hex	
11	0B	Counter 1 Limit Configuration error
12	0C	Counter 2 Limit Configuration error

Counts per Timebase The number of counts that have occurred in the timebase (1mS to 65535mS) configured for the counter.

Accumulators The Accumulators for counters 1 and 2 contain their current count values. Count limits are $-8,388,608$ to $+8,388,607$, but different limits may have been selected by configuration. If the counter has been configured for continuous counting mode, the accumulator value will wrap around if either limit is reached.

If the counter has been configured for single-shot counting mode, it counts to either limit then stops. If the counter's Preload Input is applied or the Accumulator is loaded from the CPU, the counter repeats the cycle. When the counter is at the limit, counts in the opposite direction will back it off the limit.

If a Strobe Input and the Preload Input to the counter go active in the same 0.5mS interval, the block sets both the Accumulator and the corresponding Strobe Register to the value in the counter's Preload Register.

Strobe Register When either of a counter's two Strobe inputs goes active, the counter's current Accumulator value is copied to that Strobe Register and a status

bit is set to 1 (see Status Bits, below) to inform the CPU that a strobe value has been captured. This value remains in the Strobe Register until that Strobe Input goes active again, at which time it is overwritten.

If the Latched Strobe mode has been configured, subsequent strobe inputs will not overwrite the first strobe data until the Strobe bit has been cleared by the CPU. Each time the CPU acknowledges receipt of the Strobe status bit, the application program should clear it.

If a counter's Strobe Input and Preload Input go active in the same 0.5mS interval, the block sets both the Accumulator and the Strobe Register to the value in the counter's Preload Register.

Status Bits

Word 16 of the input data sent by a High-speed Counter configured as Type B contains the following bit data:

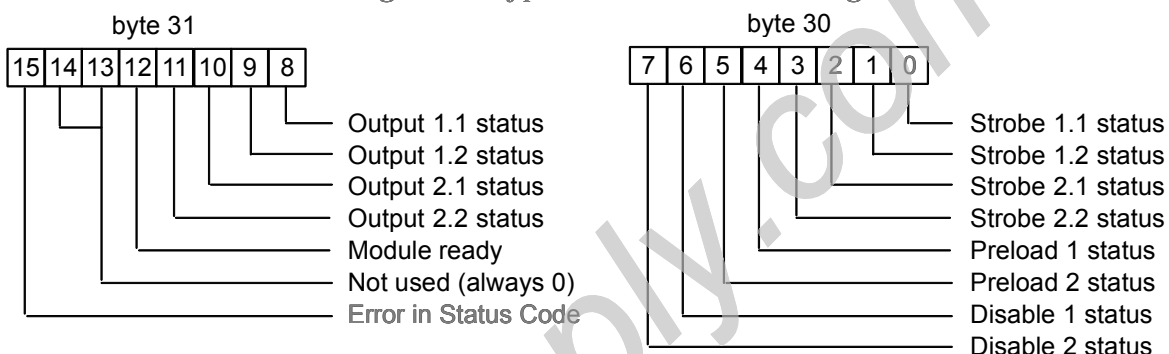

Strobe and Preload Status

The block sets one of these bits when a strobe or preload occurs. The CPU must clear the bit using the corresponding Reset Strobe or Reset Preload output.

Disable Status

The block uses these bits to indicate the present status of each Disable Input.

Output Status

The block uses these bits to indicate the ON or OFF status of each output.

Module Ready

The block sets this bit to 1 after successfully completing its powerup tests. After powerup, the block sets Module Ready status to 0 if any of the following occurs:

1. a failed switch condition on a Counter output.
2. the block is reconfigured. Sending new configuration data to the block causes the block to remove the Module Ready status momentarily, while its non-volatile memory is being updated. After completing the configuration update, the block sets the Module Ready bit to 1.
3. the block receives a Begin Packet Sequence message from another device. When the End Packet Sequence message is received or 10 seconds have elapsed, the block sets the Module Ready bit to 1.

Error

If this bit is 1, there is a count limit configuration error. To identify the counter with the configuration error, read the value in the first input word.

Output Data: Block Configured as Type B

Once each bus scan, the host bus controller sends two bytes (16 bits) of data to the block. By setting and clearing these bits, the host application program can send one command per bus scan to the block. For a block configured as Type B, outputs have the following definitions.

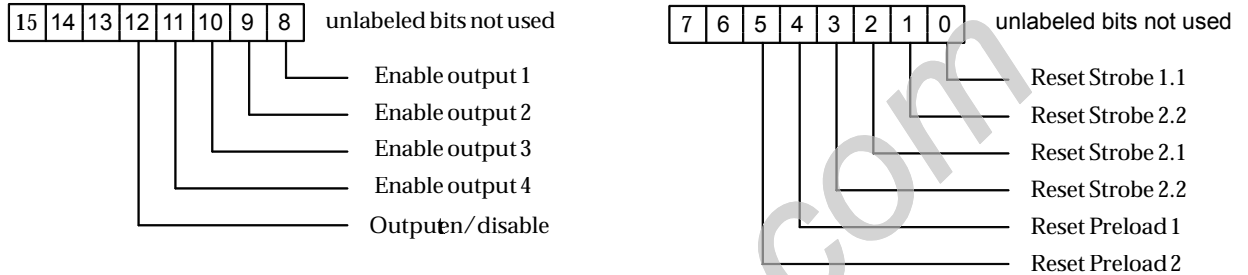

Reset Strobe clears the block's corresponding Strobe input status bit (described on the previous page). If the corresponding Strobe Input status changes to 1, the program logic should set this bit to 1 (for at least one Genius bus scan) to clear the Strobe Input status bit and then back to 0.

Reset Preload clears the block's corresponding Preload input status bit. If the corresponding Preload Input status changes to 1, the program logic should set this bit to 1 and then back to 0 the next bus scan.

Enable Output (#) bits 8 to 11 can be used in conjunction with bit 12 to selectively enable or disable the block's outputs.

If the block's configuration has been set up so that outputs are *disabled* when the block is powered up, these bits should then be used to turn them on.

During operation, if an output is already on and the host disables it using its output bit, the output will go off and stay off until it is re-enabled.

Output Enable/disable If this bit is 1, bits 8 to 11 are effective. If bit 12 is 0, bits 8 to 11 are not effective.

I/O Data: Block Configured as Type C

Input Data

Words 1 through 15 are word data (words 3 and 12 to 15 are not used if the block is configured as Type C). The values in words 4 through 11 are double-word values. Word 16 is bit data.

Word No.	Description
1	Status code
2	Counts per timebase for counter 1
3	Not used (set to 0)
4, 5	Accumulator for counter 1 (LSW in word 4, MSW in word 5)
6, 7	Strobe Register 1
8, 9	Strobe Register 2
10, 11	Strobe Register 3
12 - 15	Not used (set to 0)
16	Statusbits

Status Code This input word is only meaningful if the most significant bit of the status word (word 16) has been set to 1 by the block. It indicates a counter limit configuration error or a Home error. The value in this input word may be:

Status Code		Error Indication
decimal	hex	
10	0A	HomeError: the Home command was cleared before the Home position was found. When acknowledged by the CPU, this should be cleared by the Clear Errorcommand.
11	0B	CounterLimitConfigurationerror: the High limit is currently configured to be LOWER than the Low limit. Enter compatible limits to clear the error.

Counts per Timebase The number of counts that have occurred in the timebase (1mS to 65535mS) configured for the counter.

Accumulator The Accumulator is the “summing function” of the counter’s + loop and – loop. The + loop is made up of the A1 and B1 inputs to the counter. The – loop is made up of the A2 and B2 inputs to the counter. Count limits are –8,388,608 to +8,388,607, but different limits may have been selected by configuration. If the counter has been configured for continuous counting mode, the accumulator value will wrap around if either limit is reached.

If the counter has been configured for single-shot counting mode, it counts to either limit then stops. When a Preload Input is applied or the Accumulator is loaded from the CPU, the counter repeats the cycle. When the counter is at the limit, counts in the opposite direction will back it off the limit.

1. a failed switch condition on a Counter output.
2. the block is reconfigured. Sending new configuration data to the block causes the block to remove the Module Ready status momentarily, while its non-volatile memory is updated. After completing the configuration update, the block sets this bit to 1.
3. the block receives a Begin Packet Sequence message from another device. When the End Packet Sequence message is received or 10 seconds have elapsed, the block sets the Module Ready bit to 1.

Error if this bit is 1, there is a count limit configuration error or a Home error. Read the value in the first input word (described previously).

Output Data: Block Configured as Type C

Once each bus scan, the host bus controller sends two bytes (16 bits) of data to the block. By setting and clearing these bits, the host application program can send one command per bus scan to the block. For a block configured as Type C, these outputs have the following definitions.

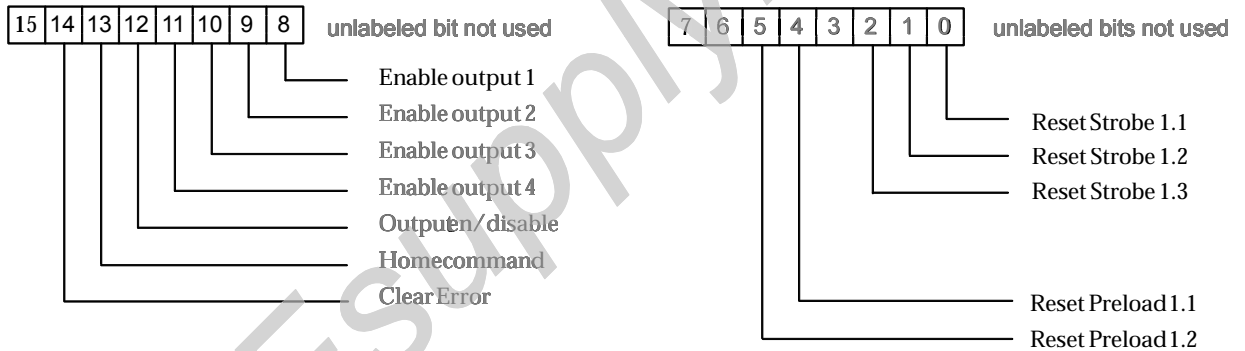

Reset Strobe clears the block's corresponding Strobe input status bit (as described on the previous pages). If the corresponding Strobe Input status changes to 1, the program logic should set this bit to 1 (for at least one Genius bus scan) to clear the Strobe Input status bit and then back to 0.

Reset Preload clears the block's corresponding Preload input status bit. If the corresponding Preload Input status changes to 1, the program logic should set the reset bit to 1 and then back to 0 the next bus scan.

Enable Output (#) bits 8 to 11 are used in conjunction with bit 12 to selectively enable or disable the block's outputs.

If the block's configuration has been set up so that outputs are *disabled* when the block is powered up, these bits should then be used to turn them on.

During operation, if an output is already on and the host disables it using its output bit, the output will go off and stay off until it is re-enabled.

Output Enable/disable If bit 12 is 1, bits 8 to 11 are effective. If bit 12 is 0, bits 8 to 11 are not effective.

-
- Home Command* for position monitoring and control applications, the program should set this bit before the Home limit switch is actuated. If this is done, when the Home limit switch is actuated, the next Marker input will cause the Home Count value to be loaded into the counter and the Home status bit will be set.
- Clear Error* This output bit is used to clear the block's error status input bit if it has been set to 1 by the block following a Home error. See "Home Command", above.

PDFsupply.com

Chapter 6

Programmed Communications

This chapter contains Datagram information for programmed messages between the CPU and the High-speed Counter:

- data formats for the Read Configuration, Read Configuration Reply, and Write Configuration Datagrams.
- data formats for the Read Diagnostics and Read Diagnostics Reply Datagrams.
- Three additional Datagrams: Read Data, Read Data Reply, and Write Data. The Write Data and Read Data Datagrams are used to send and read temporary data. This data is similar to those transmitted using Read and Write Configuration Datagrams, but it will not survive a power cycle.

Datagrams Supported by the High-Speed Counter

The High-speed Counter supports the following Datagrams.

Message Type	Subfunction Code (hex)
ReadConfiguration	02
ReadConfigurationReply	03
WriteConfiguration	04
AssignMonitor	05
Begin Packet Sequence	06
End Packet Sequence	07
ReadDiagnostics	08
ReadDiagnosticsReply	09
Report Fault	0F
Clear Circuit Fault	12
Clear All Circuit Faults	13
ConfigurationChange	22
Read Data	27
Read Data Reply	28
Write Data	29

Configuration Data Formats for the High-speed Counter

The application program can send the High-speed Counter block Read Configuration datagrams to read its configuration data, or change configuration parameters by sending it Write Configuration datagrams (configuration parameters can also be selected or changed using a Hand-held Monitor, as explained in chapter 3). Data may be transmitted in multiple bus scans up to 16 bytes at a time until all the data for the block has been sent. *A block containing firmware version 1.0 that is configured as Type A will occasionally exhibit a data transfer error when sent a Write Configuration message while it is busy counting. If this happens, send the message again.* Shorter messages are less likely to encounter this situation than longer ones. If this is a problem, it can be overcome by bracketing the Write Configuration data with Begin - End Packet Sequence messages. However, during this sequence, the maximum count rate is limited to 150kHz (firmware version 1.1 or later).

Block Configuration Data

Data format depends on the counter type that has been selected (A, B, or C). The first 6 bytes (shown as 0 - 5 in the table below) are the same for all block types.

Byte No.	Byte Description
0	Block type
1	Software revision number
2-3	Block configuration data
4	Forced output states
5	Oscillator output frequency divider (N) (=1-255)
6-69	Counter configuration(s)

Block type (byte 0) identifies the High-speed Counter block.

Block Type	Catalog Number	Block Type		
		Decimal	Hex	Binary
High-speed Counter Block	(IC660BBD102)	32	20H	00100000

“Block Configuration Data” (bytes 2 - 3) format is shown below. Unlabeled bit positions are not used.

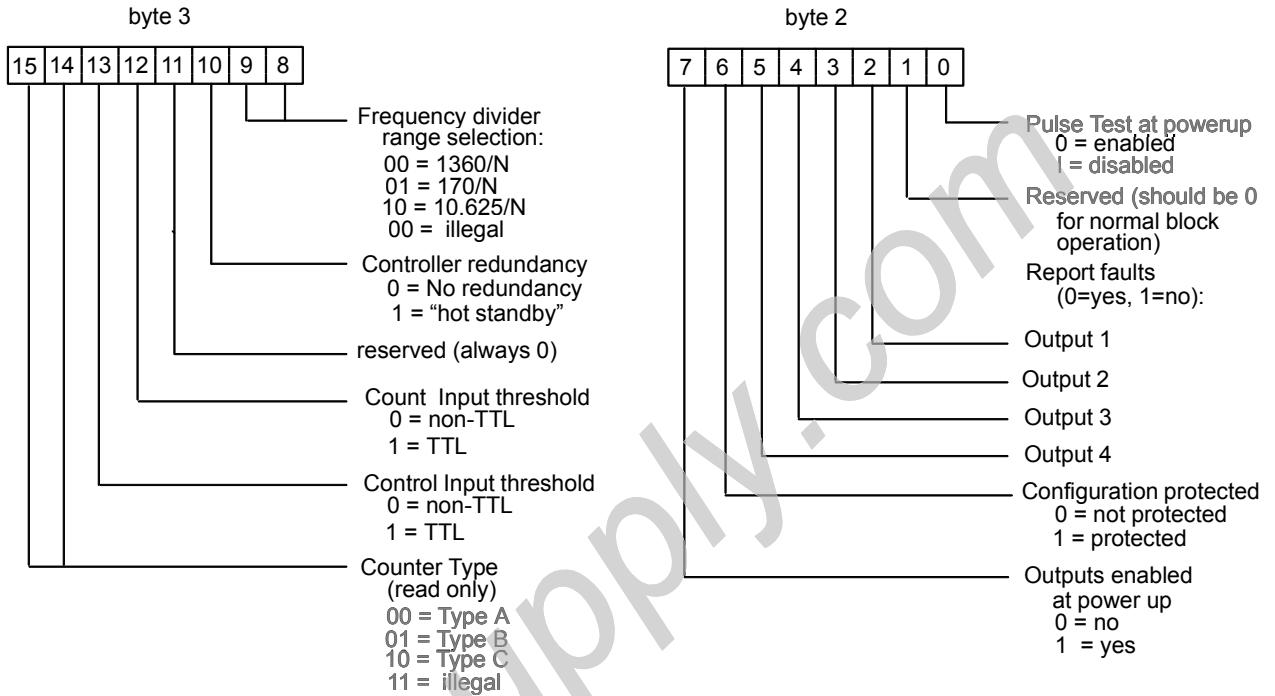

Forced Output States Data (byte 4) may be:

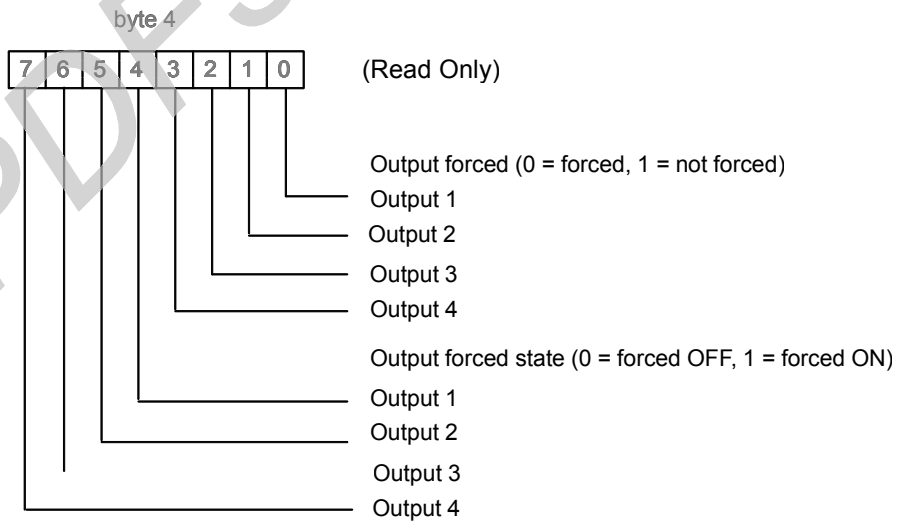

Counter Configuration Data (bytes 6-69) for a Block Configured as Type A

For the data format of bytes 0 - 5, refer back to the heading "Block Configuration Data". The LSB is always first and the MSB is last in any multibyte parameter.

Counter 1 Byte No.	Counter 2 Byte No.	Counter 3 Byte No.	Counter 4 Byte No.	Description
6,7	20,21	34,35	48,49	Counterconfiguration
8,9	22,23	36,37	50,51	Timebase value (1-65535)*
10,11	24,25	38,39	52,53	Count limit, high**
12,13	26,27	40,41	54,55	Count limit, low**
14,15	28,29	42,43	56,57	ON Preset**
16,17	30,31	44,45	58,59	OFF Preset**
18,19	32,33	46,47	60,61	Preload value**

Bytes 62-69 are unused.

* unsigned binary value

** 2-byte signed two's complement value

Counter configuration (bytes 6 and 7, 20 and 21, 34 and 35, 48 and 49) may be:

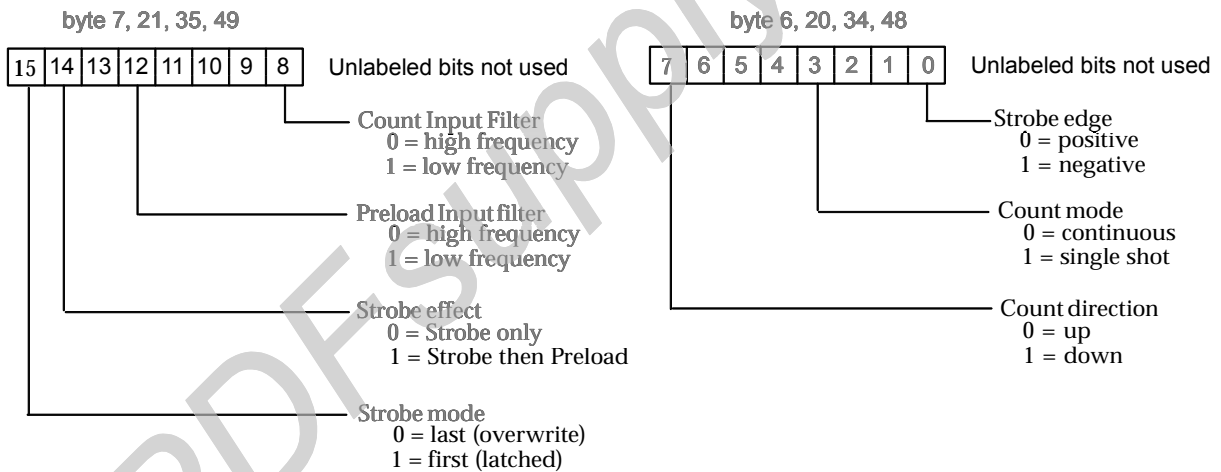

Counter Configuration Data (bytes 6-69) for a Block Configured as Type B

For the data format of bytes 0 - 5, refer back to the heading “Block Configuration Data”. The LSB is always first and the MSB last in any multibyte parameter.

Counter 1 Byte No.	Counter 2 Byte No.	Description
6,7	38,39	Counterconfiguration
8,9	40,41	Timebase value (1 - 65535)*
10-13	42-45	Count limit, high**
14-17	46-49	Count limit, low**
18-21	50-53	ON Preset 1**
22-25	54-57	OFF Preset 1**
26-29	58-61	ON Preset 2**
30-33	62-65	OFF Preset 2**
34-37	66-69	Preload value **

- * unsigned binary value
- ** 4-byte signed two's complement value

Counter configuration (bytes 6 and 7, 38 and 39) may be:

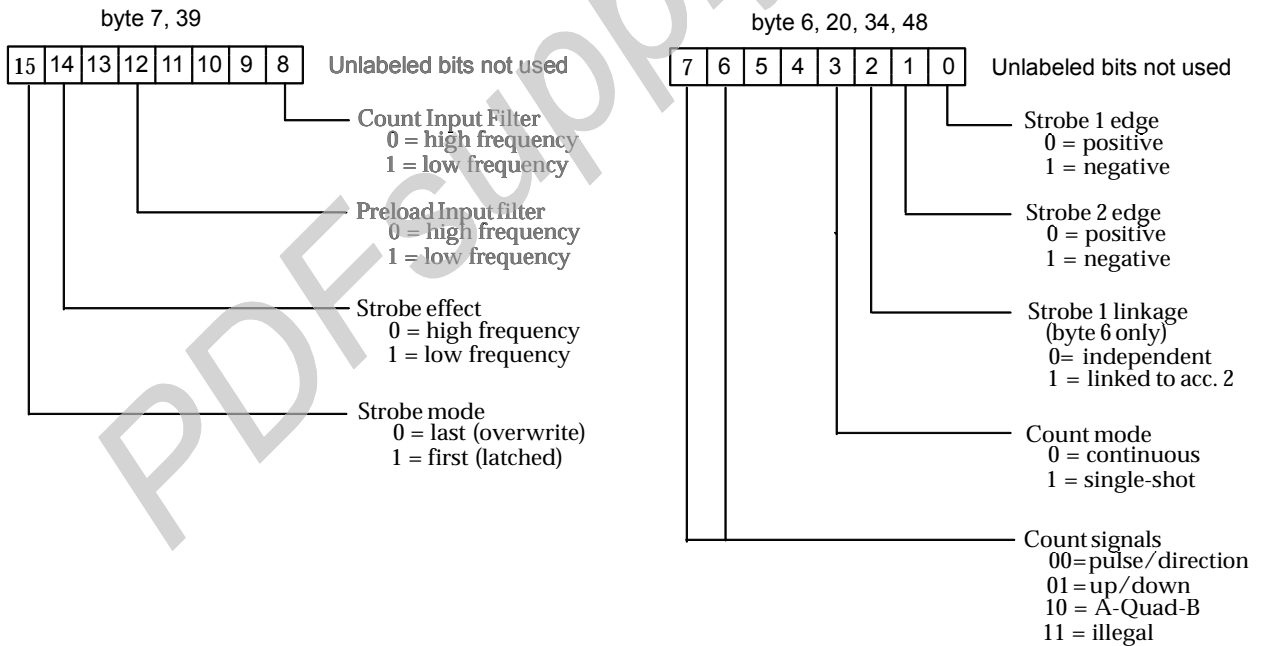

Counter Configuration Data (bytes 6-69) for a Block Configured as Type C

For the data format of bytes 0 - 5, refer back to the heading "Block Configuration Data". The LSB is always first and the MSB last in any multibyte parameter.

Counter 1 Byte No.	Description
6,7	Counterconfiguration
8,9	Timebase value, 1-65535*
10-13	Count limit, high**
14-17	Count limit, low**
18-21	ON Preset 1**
22-25	OFF Preset 1**
26-29	ON Preset 2**
30-33	OFF Preset 2**
34-37	ON Preset 3**
38-41	OFF Preset 3**
42-45	ON Preset 4**
46-49	OFF Preset 4**
50-53	Preload 1 value**
54-57	Preload 2 value**
58-61	Home position**
62-69	Unused

* unsigned binary value
 ** 4-byte signed two's complement value

Counter configuration (bytes 6 and 7) may be:

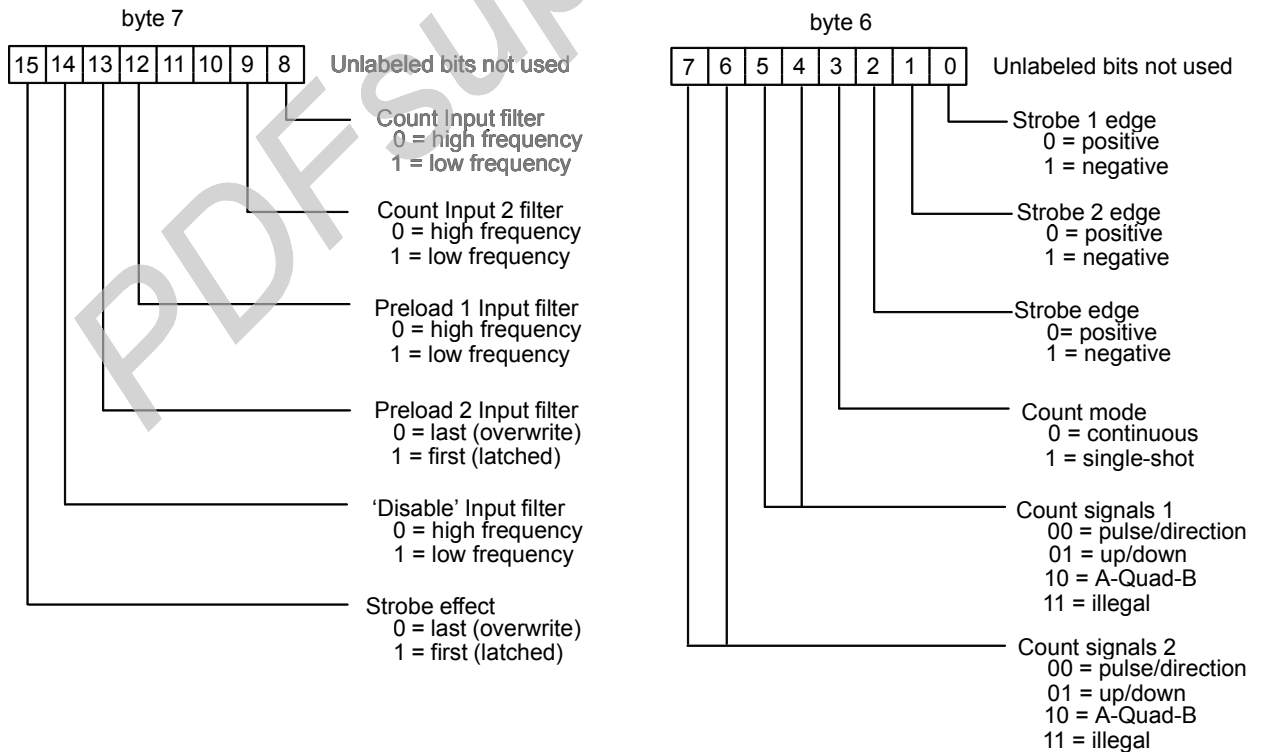

Diagnostics Data Formats for the High-speed Counter

The application program can send the block Read Diagnostics datagrams to request current diagnostic information. Diagnostics can be read from a block even if it has been configured not to automatically report faults to the CPU.

Block Diagnostics Data

Diagnostic data for a High-speed Counter block is listed below. All of the data may be transmitted by the block in a single message.

Byte No.	Byte Description
0	Block type
1	Software revision number
2	Blockdiagnostics.
3	Not used.
4	Output 1 faults. Bit 5=1 indicates Failed Switch
5	Not used.
6	Output 2 faults. Bit 5=1 indicates Failed Switch
7	Not used.
8	Output 3 faults. Bit 5=1 indicates Failed Switch
9	Not used.
10	Output 4 faults. Bit 5=1 indicates Failed Switch
11	Not used

Block diagnostics (byte 2) may be:

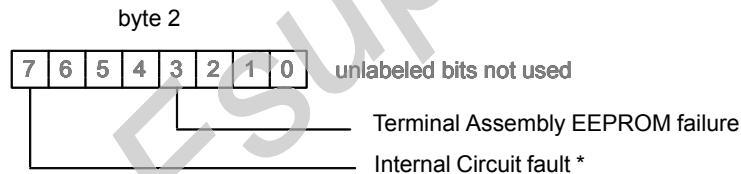

* Replace electronics assembly.

Write Data/Read Data/Read Data Reply Datagrams

When the block powers up, it copies configuration data from its EEPROM memory into RAM. The Write Data command can be used to temporarily replace some of this data with other values. If data has been entered using a Write Data Datagram, the block will return that data in its Read Data Reply message. Otherwise, it will return the original configured value in the Read Data Reply. To obtain a Read Data Reply, a valid Read Data message must be sent to the block. These messages are not used by the Hand-held Monitor, so all temporary changes must be handled by the CPU application program.

The following illustration shows the effects of Read/Write Data and Read/Write Configuration messages to the High-speed Counter.

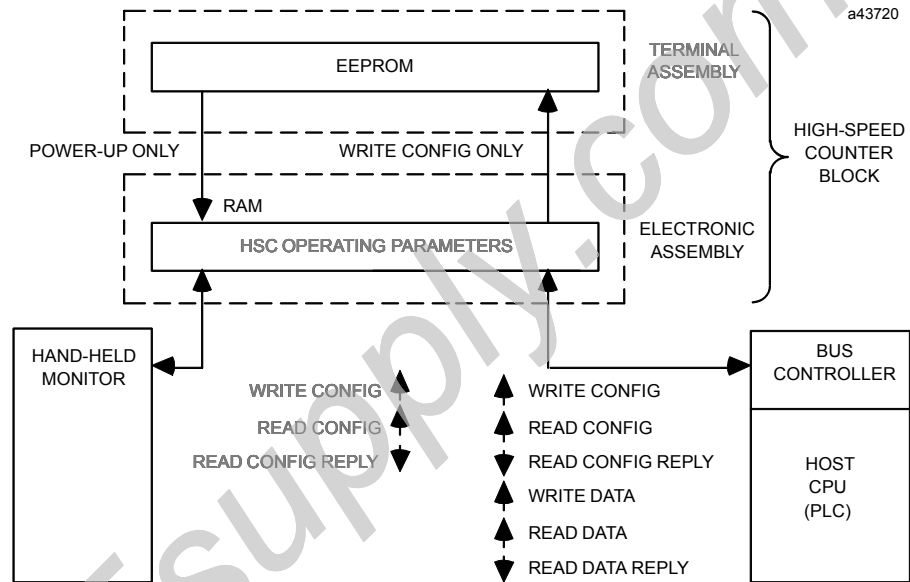

Read Data

Subfunction Code: 27 hex

This Datagram can be used to read specific data from a High-speed Counter block's RAM memory.

Byte No.	Byte Description
0	Data type code (see list below)
1	Counter number (1-4) or 0 if not counter data

Data Type Codes

The value in byte #0 of the message will be one of the following numbers, which identifies the type of data to be returned in the Read Data Reply:

Hex	Dec	Hex	Dec
00	00 = null		
01	01 = read Accumulator value	15	21 = read counter OFF Preset #1
02	02 = read counter high limit	16	22 = read counter OFF Preset #2
03	03 = read counter low limit	17	23 = read counter OFF Preset #3
05	05 = read counter direction (type A only)	18	24 = read counter OFF Preset #4
06	06 = read counter timebase	1F	31 = read counter Preload #1
08	08 = read Home position	20	32 = read counter Preload #2
0B	11 = read counter ON Preset #1	21	33 = read counter Preload #3
0C	12 = read counter ON Preset #2	22	34 = read counter Preload #4
0D	13 = read counter ON Preset #3	32	50 = read divisor (N) of oscillator output
0E	14 = read counter ON Preset #4		

Example

To read ON Preset #1 for counter 1, the Read Data datagram is:

01 0B

Read Data Reply

Subfunction Code: 28 hex

The High-speed Counter sends a Read Data Reply Datagram when it receives a Read Data Datagram.

Byte No.	Byte Description
0	Data type code (see list above)
1	Counter number (1-4) or 0 if not counter data
2-5	Data value (LSB in byte 2) bytes 4 and 5 not used for type A counter

For data type code 05, a 0 is returned in byte 2 for up direction and a 1 is returned in byte 2 for down direction.

Write Data

Subfunction Code: 29 hex

This Datagram is used to send temporary data to the High-speed Counter's RAM memory. The block does not store this data in EEPROM. It is not retained through a power cycle or displayed on a Hand-held Monitor. Subsequently, if any counter configuration data is changed by a Write Configuration message from the CPU or HHM, the EEPROM configuration is asserted for all parameters of that counter.

Byte No.	Byte Description
0	Data type code (see list below)
1	Counter number (1-4) or 0 if not counter data
2-5	Load value (LSB of byte 2) bytes 4 and 5 not used for type A counter

Data Type Codes

The value in byte 0 of the message will be one of the following numbers, which identifies the type of data that follows:

Hex	Dec
00	00 = null
01	01 = write Accumulator value
02	02 = write counter high limit
03	03 = write counter low limit
04	04 = write counter Accumulator adjust increment
05	05 = write counter direction (type A only)
06	06 = write counter timebase
08	08 = write Home position
0B	11 = write counter ON Preset #1
0C	12 = write counter ON Preset #2
0D	13 = write counter ON Preset #3
0E	14 = write counter ON Preset #4
15	21 = write counter OFF Preset #1
16	22 = write counter OFF Preset #2
17	23 = write counter OFF Preset #3
18	24 = write counter OFF Preset #4
1F	31 = write counter Preload #1
20	32 = write counter Preload #2
21	33 = write counter Preload #3
22	34 = write counter Preload #4
32	50* = write divisor (N) of oscillator output

* This command can only be used to send the oscillator divider. To change the range, it is necessary to use a Hand-held Monitor or a Write Configuration command.

The value in byte 1 defines the counter number for which the data is intended. Use 0 for data type 50 (hex).

Bytes 2 - 5 must contain the new data to be inserted. Data types not requiring all four bytes always start with byte 2 as the least significant byte of data. For data type 05, byte 2 should be 0 for up count direction and 1 for down count direction.

This appendix describes the following High-speed Counter applications:

- Monitoring and controlling differential speeds
- Direction-dependent positioning
- Count doubling
- Counter cascading
- Accurately measuring pulse rates
- Measuring RPM from a feedback device
- Tolerance checking
- Measuring total material length
- Material-handling conveyor control
- Timing pulse generation
- Digital velocity control
- Dynamic counter preloading
- Carousel tracking

Monitoring and Controlling Differential Speeds

Many industrial applications require machines such as cutters, conveyors, or nip rolls to operate at precise differential speeds. The Type C counter, which could be used with a minimum of controller support, is most suited for this application. Type A or Type B counters could also be used with the aid of a controller.

The pulses representing the speed of each machine can be separately fed into the plus and minus loops of the Type C counter. The Accumulator will automatically track and indicate the difference in speed of the two machines. The sign of the Accumulator value will indicate which pulse stream count is greater and the Accumulator will indicate the total accumulated count difference. The Counts per Timebase register will indicate the present rate difference; its sign will indicate which is greater.

Depending on the count signal types, each channel of the counter can be independently programmed to operate in any one of its three modes:

1. Pulse/direction
2. Up/down
3. A-Quad-B

The sign (+ or -) and magnitude of the deviation from the desired difference can be used as feedback to provide automatic control for the speed regulation of the machines.

Direction-Dependent Positioning

Some applications require direction-dependent positioning. An example is an operation where a crane, on tracks, has to perform certain maneuvers while travelling 100 feet in one direction and different ones while travelling 100 feet in the reverse direction. This example uses the Type B configuration, with 2 counters configured to operate in the A-Quad-B mode. Both counters should be driven by the same A-Quad-B signals and connected so they count in opposite directions when the crane is moving, as shown on the following page.

The counter operating mode, limits, and preload value can be set so the Preset outputs are direction-sensitive. In this example, this is done by using the single-shot mode and preloading Counter 2 so that it counts only when the crane is moving in the reverse direction (right to left).

The counters are both preloaded at the start point. Counter 1 will count up from 0 to 100 for the left-to-right direction, and count down for travel in the right-to-left direction. Counter 2 will count up (from -100 to 0) only when the crane travels from right to left.

For this example, counter 1 is configured with a Preload value of 0. An ON condition for Preset 1 is selected which will turn on a loading device when the crane has travelled 75 feet to the right. The direction of travel is reversed at the stop point, and as the crane travels back from right to left, ON Preset 1 of counter 2 activates an unloading device when the crane has travelled 40 feet to the left (ON Preset is -60).

Finally, Preset 2 of counter 2 turns its output on when the crane has travelled 75 feet to the left (ON Preset is -25).

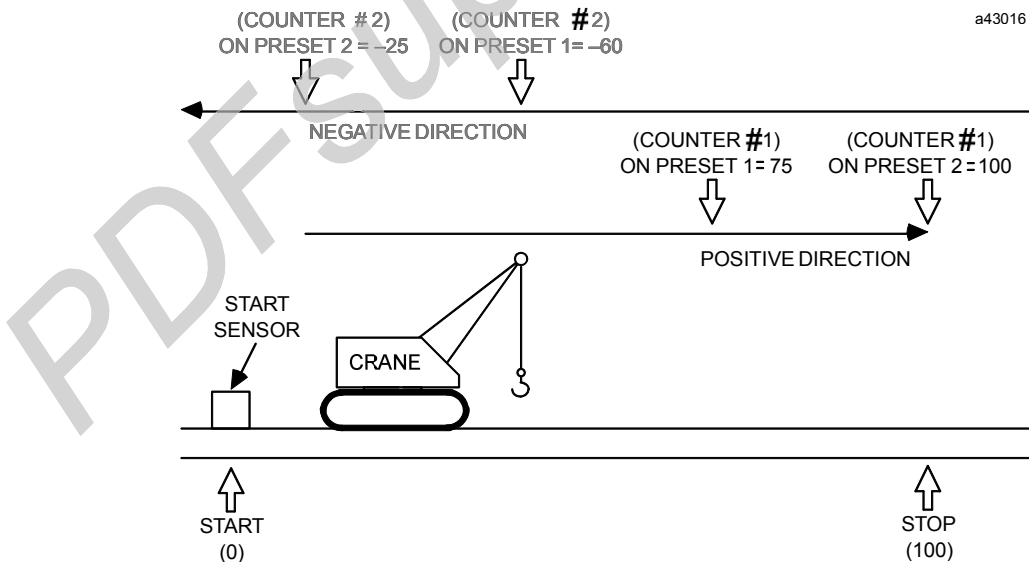

Typical Block Wiring for this Example

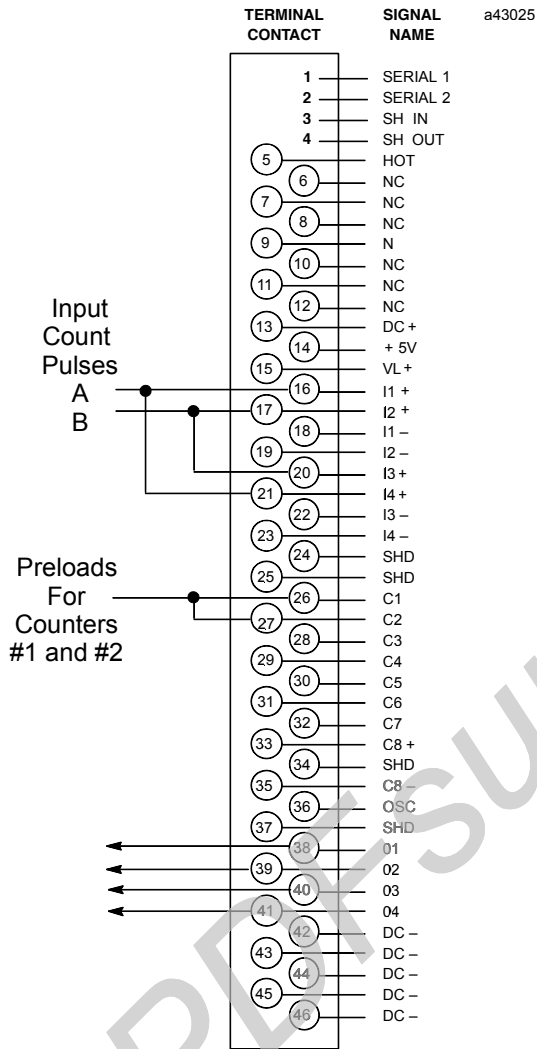

Suggested Configuration

Counter type	type B (two counters)
Counter Operating mode	A-Quad-B
Count mode	one-shot (both counters) (non-continuous)
Counter 1 Preload	0
Counter 2 Preload	-100
Counter 1 limits	0 to 100
Counter 2 limits	-100 to 0
Block Power	115 VAC and/or 10/30VDC
Load power	connect VL+ to either DC+ (13) or +5V (14).

Counter Number	Crane Direction	Count Direction
Counter 1	→	UP
Counter 2	→	Not counting
Counter 1	←	DOWN
Counter 2	←	UP

Counter 1:	
Output 1	ON for Counter 1 w 75 OFF for Counter 1 < 75
Output 2	ON for Counter 1 w 100 OFF for Counter 1 < 100
Counter 2:	
Output 3	ON for Counter 2 w -60 OFF for Counter 2 < -60
Output 4	ON for Counter 2 w -25 OFF for Counter 2 < -25

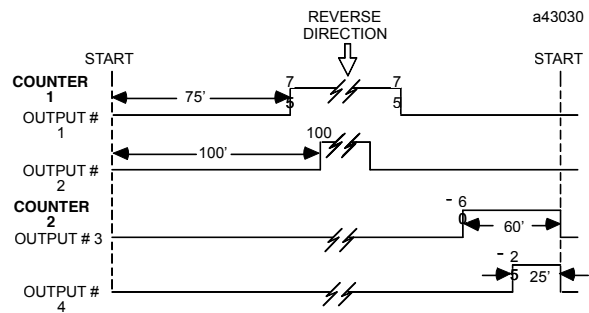

Count Doubling

a43026

Some applications may require count doubling - either because of the nature of the application, or to adjust the count levels for different gearing ratios. Whatever the reason, this simply means that for each actual input count pulse, the counter register either increases or decreases by two counts. Whether the count increases or decreases depends on the count direction at that time.

The type C counter may be used for count doubling. This can be accomplished by connecting the same count pulses into both count input loops with the direction for loop 2 the opposite of that for loop 1.

Count Doubling for a Single Pulse Stream

For a single input pulse stream, configure both channels of the type C counter to operate in the Up/Down mode. Connect the signal input to both the UP+ (I1+) and DN- (I4+) contacts of the terminal strip, as shown at right.

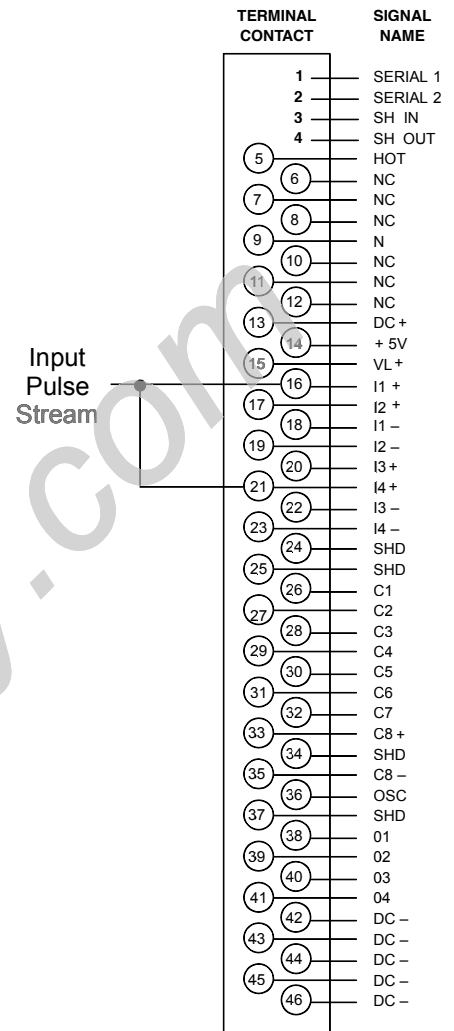

Count Doubling for Quadrature-type Inputs

a43027

For quadrature type input signals, a single A-Quad-B cycle would cause the counter register to increase or decrease by 8 (depending on the count direction at that time). For quadrature-type inputs, configure both channels of the type C counter to operate in A-Quad-B mode. Connect the signals as shown at right. Observe the signal connection interchanges between the plus loop (I1+ and I2+) and the minus loop (I3+ and I4+) to achieve the opposite direction commands for the two loops.

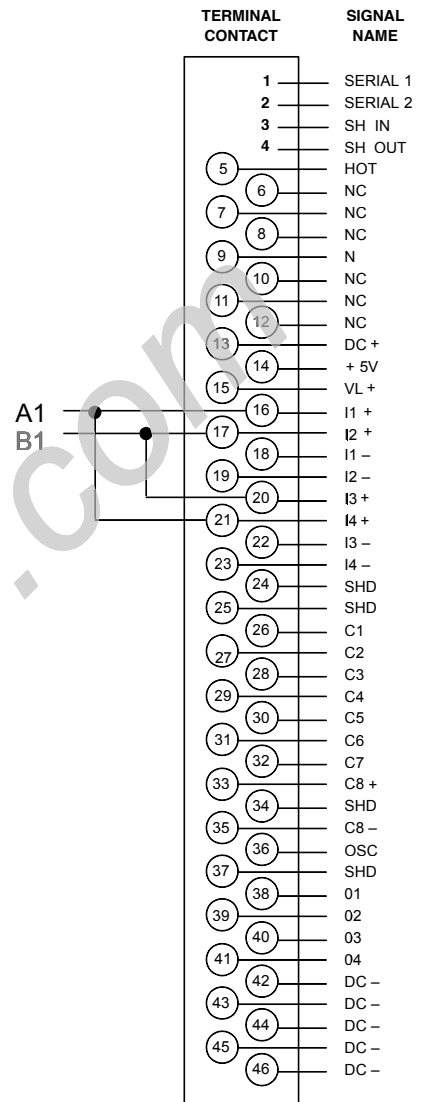

Counter Cascading

Type A counters can be cascaded to accumulate greater count values than are possible with a single 2-byte counter. This can be accomplished by using the Preset output of one counter for the count input of the next:

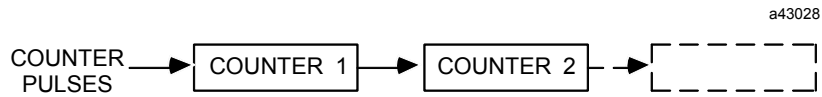

Example

If a 4-byte Up Counter is required, use two counters configured for the Up direction and:

1. Set the Count Limits for both counters at their maximum values:

LOW = -32768
HIGH = +32767

2. Set the output Preset for counter #1 at:

ON = 0
OFF = 150



3. Connect the Counter 1 output to the Counter 2 count input.
4. Connect the count pulse stream to the Counter 1 count input.

Similarly, Down Counters can be cascaded by configuring all counters for the Down direction, setting the limits at the maximum values, and reversing the output Presets.

Example

OFF = 0
ON = 150

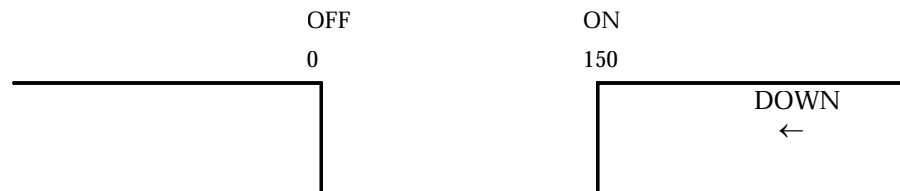

Measuring or Comparing Pulse Rates

The High-speed Counter block can accurately measure a pulse rate or compare the rates of two pulses. If the measured pulse rate will be less than 1 kHz, one Type A counter can be used, as described in example 1, below. If the measured pulse rate may exceed 1 kHz, the block should be configured for Type B counter operation, and set up as described in example 2.

Using a Reference Pulse

To accurately measure a pulse rate, a pulse stream with a known frequency of up to 200kHz is used as a reference. The reference frequency should be at least 10x the pulse rate to be measured.

The reference pulse can come from an external source, or from the block's own oscillator output (OSC). If the OSC output is used, it can be configured for a frequency up to 194.3kHz (kHz=1360/N=7) (page 3-9). To use the OSC output, the block must be configured for TTL-level Counter Input Threshold voltage (page 3-10).

The OSC output can be jumpered directly to the counter input terminal.

Example 1: Measuring a Pulse Rate Less Than 1 kHz

For this application, configure the block for Type A counter operation. Configure the Strobe Effect feature for "Strobe Then Preload". Configure a Preload value of 0, and configure the Count Direction to be UP.

Connect the reference pulse to the Count Input. Connect the pulse to be measured to the Strobe input.

As each measured pulse is received, the number of reference pulses received is captured in the Strobe Register, and the Accumulator is preloaded back to 0. The Strobe Register always indicates the number of known-frequency pulses between each measured pulse, and its instantaneous rate can easily be calculated.

Example 2: Measuring a Pulse Rate Over 1 kHz

For this application, the block should be configured for Type B counter operation. The Strobe Linkage feature should be configured to "Coupled to Accumulator 2" (linked) (page 3-11). Apply the pulse rate to be measured to the input of Counter 2, as illustrated.

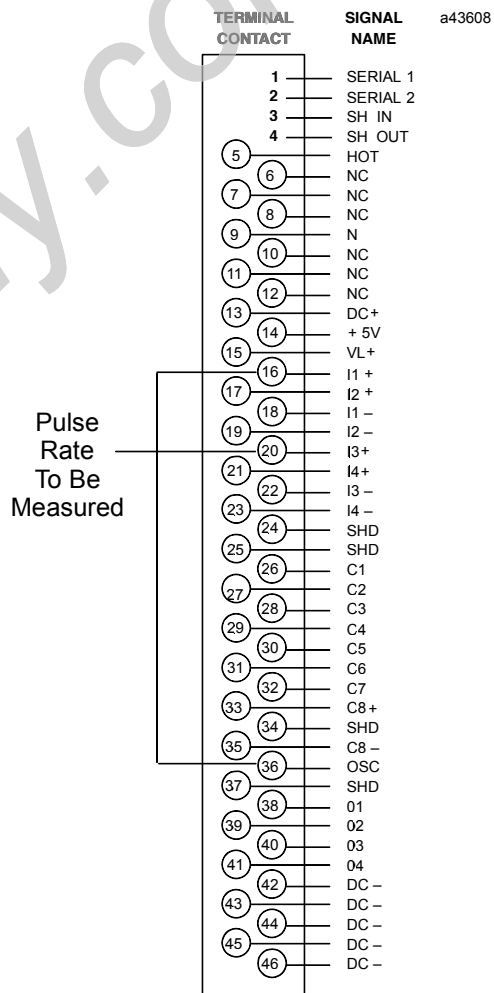

At the rising edge of each measured pulse, the block will:

1. Count the #2 Counter up (or down).
2. Transfer the contents of Counter 1 into Strobe Register 1.1.
3. Transfer the contents of Counter 2 into Strobe Register 2.1.

Steps 2 and 3 occur simultaneously, so Strobe Register 2.1 always contains the number of measured pulses and Strobe Register 1.1 always contains the corresponding number of measuring pulses to within ± 1 count.

Counter 1			Counter 2		
Pulses	Accumulator	Strobe Register	Strobe Register	Accumulator	Pulses
→	1				
→	2				
→	3				
→	4				
	•				
	•				
→	12	→ 12	1	← 1	←
→	13				
→	14				
→	15				
	•				
	•				
→	24	→ 24	2	← 2	←

The block automatically transmits this Strobe Register data to the CPU. The application program should:

1. Find the difference between two successive sets of Strobe Register values. In the illustration above,
 - A. for Strobe Register 1.1: $24 - 12 = 12$
 - B. for Strobe Register 2.1: $2 - 1 = 1$
2. Divide the number of pulses from Strobe Register 1.1 by the number of pulses from Strobe Register 2.1. This will give the ratio between the pulse rates. In the example, the ratio is 12 to 1.
3. To find a measured pulse rate, the program should divide the reference pulse rate by the number found in step 2. If the reference from the OSC output were 194.3kHz, the measured pulse rate for the example would be 16.2kHz ($194.3/12$).

Measuring Pulse Time

The High-speed Counter block can accurately measure the on/off time of an input pulse, using another pulse such as the block's OSC output as a reference. The block should be configured for Type B counter operation. This application will require one of the block's two counters.

Using the Oscillator Output

If the oscillator output (OSC) is used, it should be jumpered directly to the count input terminal of the counter. To receive the OSC signal as an input, the block must be configured for TTL-level Counter Input Threshold voltage (page 3-10). The Oscillator Frequency should be configured for the intended resolution. For example:

Resolution	Frequency
.1mS	10kHz
1mS	1kHz

10kHz is the default frequency. Page 3-9 explains how to change the Oscillator Frequency if needed.

Counter Configuration

The counter's configuration can be:

- A. Strobe 1 edge = positive (the default)
- B. Strobe 2 edge = negative (see page 3-13)
- C. Count mode = continuous (the default)
- D. Count input signals = Pulse/Direction (the default)

Either Strobe edge could be configured as positive, and the other strobe edge as negative. The discussion that follows assumes that the counter has been configured as shown above.

Measuring a Positive/Negative-going Pulse

To measure a positive and negative-going pulse, connect the pulse to the counter's Strobe 1 and Strobe 2 inputs. The block will capture the oscillator's current count value on each of the input pulse edges.

a43609

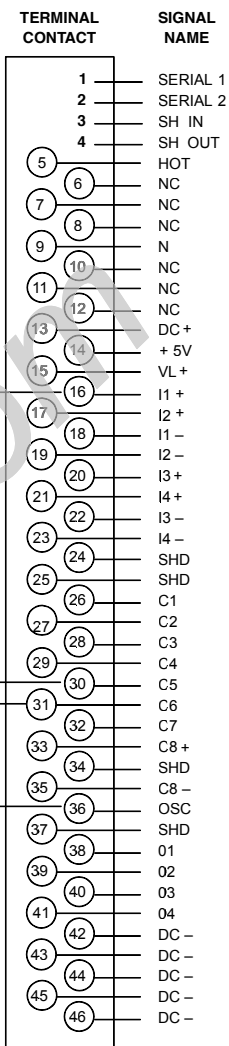

When the block senses the positive edge of the signal, it moves the current value of the counter's Accumulator to the Strobe 1 register. When the block senses the negative edge, it moves the current value of the Accumulator to the Strobe 2 register. Both of these values are supplied to the CPU. The application program logic must calculate the pulse length by subtracting one value from the other:

A. For a positive-going pulse:

$$\text{Strobe Reg 2} - \text{Strobe Reg 1} = \text{pulse time}$$

B. For a negative-going pulse:

$$\text{Strobe Reg 1} - \text{Strobe Reg 2} = \text{pulse time}$$

The result of this subtraction will be an integer value. The length of time it represents will depend on the frequency of the reference oscillator.

Frequency	Each Count Represents
10kHz	.1mS
1kHz	1mS

Example

In this example, the Oscillator Frequency is 10kHz. The block receives three pulses from the oscillator input for each input received from the pulse being measured. Multiplying this by the value shown in the table above gives .3mS pulse time.

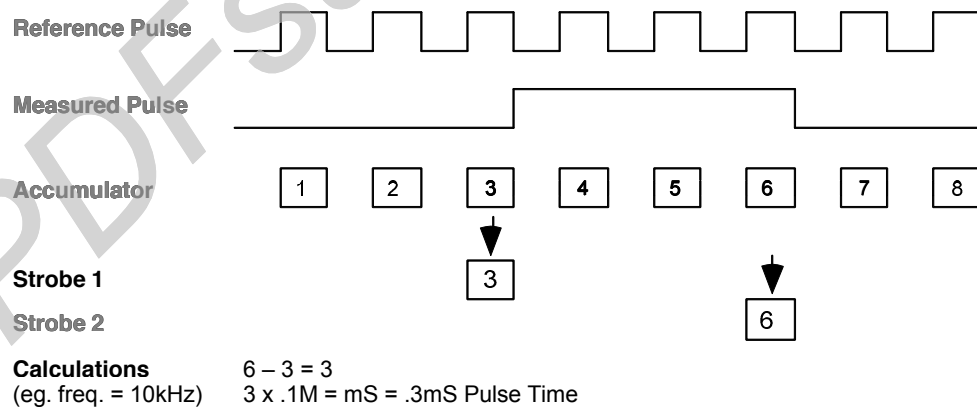

Suggestion

Just before measuring the pulse, preload the counter Accumulator to 0. This will prevent a rollover of the Accumulator value during the measurement period, and eliminate the need for the application program to compensate for it.

Measuring a Positive-Going Pulse Only

If only a positive-going pulse will be measured, it can be connected directly to the Preload Input instead of the Strobe 1 Input. If this is done, the Strobe 2 reading will give the pulse length directly.

As with the previous method, the result is an integer value whose resolution depends on the frequency of the reference pulse.

Example

In this example, the Oscillator Frequency is 10kHz. The Preload input resets the Accumulator to 0. Therefore, the Strobe 2 Register contains the number of reference pulses received since the last occurrence of the measured pulse. Like the previous example, this number is multiplied by .1mS to find the pulse time.

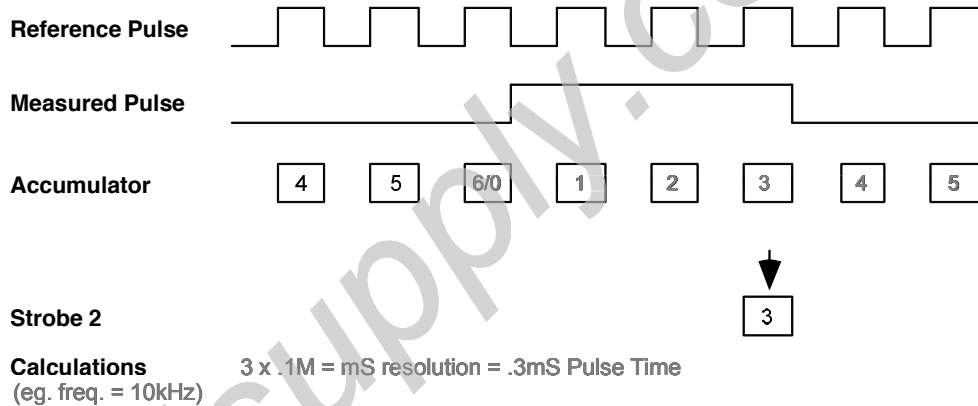

RPM Indicator

The High Speed Counter can be used as a position/motion indicator when connected to a feedback device (such as an encoder) that is coupled to a rotary motion. The block can be configured for Type A, B, or C operation; only one counter is required for this application. RPM indication can be read directly from the Counts per Timebase register for some applications, or the application program can calculate RPM using the equation below.

$$\text{RPM} = \frac{\text{CTB}}{\text{PPR}} \times \frac{1}{T_M}$$

where:

CTB = counts/timebase reading from the counter

PPR = pulse/revolution produced by the feedback device

T_M = timebase in MINUTES

Assigning the Timebase

If a timebase is selected such that $1/T_M$ divided by PPR is some integer power of 10, the Counts per Timebase register gives a direct reading of RPM with an assumed decimal location. Longer timebase settings will give better RPM resolution. This is illustrated in the examples below.

Example 1

A feedback device produces 1000 pulses per revolution. Its Counter Timebase is configured to be 600ms. For this example, suppose that the Counts per Timebase Register contained the value 5212.

then $T = 600 \text{ ms}$ B $60000 \text{ ms/min} = .01$ and $1/T = 100$

$$\text{RPM} = 5212 \text{ B } 1000 \times 100 = 521.2$$

CTB reading is RPM with .1 RPM resolution.

Example 2

Assume the same conditions as example 1, except the timebase is now set to 60 ms, which gives $T = 60 \text{ B } 60000 = .0001$ and $1/T = 1000$.

Since the motion is turning at the same speed as in example 1, the CTB reading now equals 521

$$\text{and RPM} = 521/1000 \times 1000 = 521.$$

CTB reading is now RPM with 1 RPM resolution.

Tolerance Checking

The block can accurately measure the length of parts on a transport conveyor for tolerance checking. A pulse feedback device should be coupled to the conveyor. Each pulse from the device will represent a known length of conveyor movement.

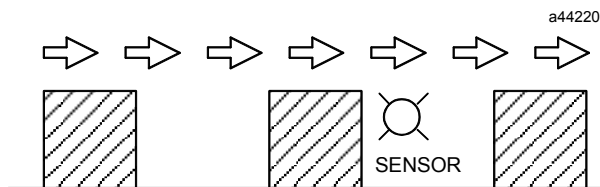

The block should be configured for Type B counter operation. This application will require one of the two counters.

The counter configuration should be:

- A. Strobe 1 edge = positive (the default)
- B. Strobe 2 edge = negative (see page 3-13)
- C. Count mode = continuous (the default)
- D. Count input signals = Pulse/Direction (the default)

Connect the feedback device pulses to the Counter input. Connect the sensor input to the counter's Strobe 1 and Strobe 2 inputs.

The Counter's Accumulator will store total number of pulse inputs received from the feedback device. When the sensor detects a part, the current value of the Accumulator will be copied to Strobe Register 1. When the part has passed the sensor, the current value of the Accumulator will be copied to Strobe Register 2. Therefore, the length of the part is indicated by the difference between the two Strobe Register readings. Both of these values are supplied to the CPU. The application program can then:

- A. Subtract Strobe Register 1 from Strobe Register 2 to find the number of pulses that occurred.
- B. Multiply this number by the known distance represented by each pulse to find the length of the part.
- C. Compare this length against the desired tolerance limits.
- D. If a part is out of tolerance, it can be marked or separated from the rest.

Measuring Total Material Length

The total length of multiple pieces of material, such as plate glass, plastic strips, or lumber, can be measured with the High-speed Counter.

This application uses an encoder geared to a transport conveyor to provide the count input increments, and a sensor to detect material as it passes.

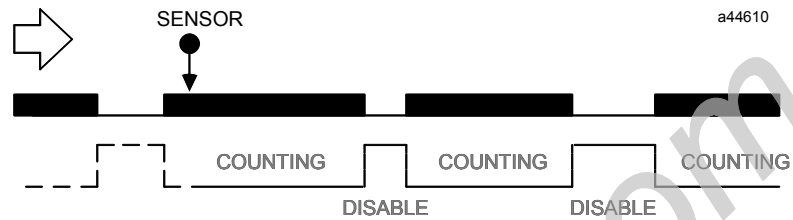

The block should be configured for Type B counter operation.

Connect the encoder to the counter's Count Input. Connect the sensor to the Disable Input.

Count inputs from the encoder will increment the Accumulator only while a piece of material is passing through the sensor. The total length of all pieces will be accumulated until the counter is reset (Preloaded) for the start of a new batch. The application program can convert the count units from the accumulator to the actual units of length being measured.

Material-handling Conveyor Control

When transported material must be stopped momentarily for inspection or modifications, the High-speed Counter's Preset outputs can control conveyor slowdown and stop points.

Use an encoder geared to the transport conveyor to provide the count input increments. Use a sensor to detect material as it passes on the conveyor.

Determine where the material should begin to slow down, and where the material should stop. Find out how many encoder counts are equivalent to each of these two distances.

The block should be configured for Type B counter operation.

Configure Preset Output 1 to turn on at the slowdown point, by entering the number of counts from the sensor to the point where slowdown should begin.

Configure Preset Output 2 to turn on at the stop point, by entering the number of counts from the sensor to the inspection station.

Connect the sensor to the Preload Input of the counter to restart the counter at 0 for each piece of material that passes (only one piece can be between the sensor and the stop point in this configuration).

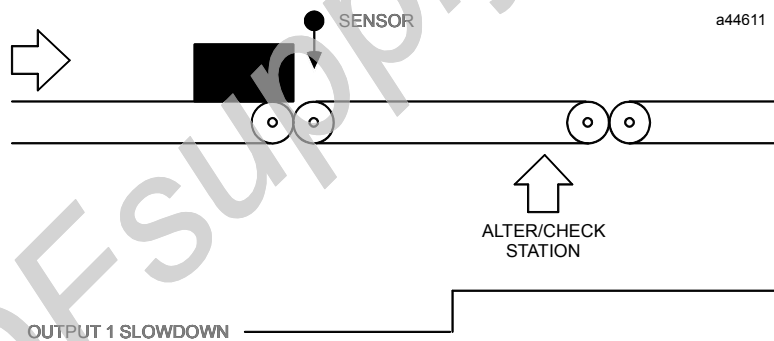

Timing Pulse Generation

Applications requiring an accurate timing pulse can use the High-speed Counter to generate the pulse at the required frequency. The specified pulse width will be accurate to 0.5mS of resolution.

The block's Oscillator output, or an external oscillator, can be used to provide the needed reference frequency.

Configuration

The block can be configured for Type A counter operation. This application will use only one of the block's available counters.

To use the OSC signal as an input, the block must be configured for TTL-level Counter Input Threshold voltage (page 3-10). The Oscillator Frequency should be configured for the intended resolution.

Resolution	Frequency
.1mS	10kHz
1mS	1kHz

10kHz is the default frequency. Page 3-9 explains how to change the Oscillator Frequency if needed.

The counter's default configuration should be changed as shown:

- A. Counter Input Threshold = TTL (for OSC input)
- B. Count Limits:
 1. upper limit = Number of counts at the selected frequency that represent one complete timing cycle.
 2. lower limit = 0
- C. Output Presets:
 1. On Preset = Number of counts that elapse *between* output pulses.
 2. Off Preset = 0

The way this works is shown by the following example:

Digital Velocity Control

The High-speed Counter, together with an Analog Output module and a drive amplifier, can be used to provide accurate motor velocity control. The commanded velocity is generated by connecting the block's oscillator output to the up count input of Counter 1.

The OSC input (or an external oscillator) provides a steady counting pulse to the up count input. The output of the counter provides the accumulator count value to the CPU. This data can be transferred by the CPU to an analog output module. An output from this module, in turn, controls the amplifier driving the motor.

During system operation, the motor's velocity can be changed by changing the frequency of the OSC output with a Write Data command (see page 6-10).

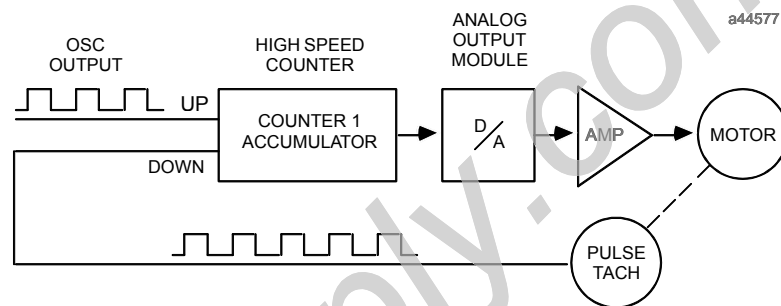

A pulse tachometer is connected to the block's down count input. This tachometer provides count pulses that are fed into the down count input of the same counter. As a result, the counter Accumulator reaches a stable value when the motor is turning at the commanded velocity.

Configuration

The block should be configured for Type B counter operation. This application will use only one of the block's two counters.

To use the OSC signal as an input, the block must be configured for TTL-level Counter Input Threshold voltage (page 3-10).

The counter should be configured for Up/Down counting mode. The Oscillator Frequency should be configured to produce the initial velocity required when the system is powered up.

Dynamic Counter Preloading

Applications using a High-speed Counter to track the position of a material conveyor or machine slide may need to be preloaded accurately at a given reference point while in motion. Simply connecting a limit switch to the counter's Preload Input does not give repeatable, accurate results because errors are introduced by:

1. Variations in the actuation point of the limit switch and
2. Preload Input Filter delay when actuated at different speeds.

For accurate repeatability, the Home feature of the Type C counter configuration should be used. This application requires a marker pulse (usually 1 per revolution) from the position feedback device (encoder). The limit switch should be placed so that it will be encountered approximately halfway between marker pulses. When the limit switch is reached, the next marker pulse causes the block to preload the Accumulator with the desired value. The limit switch should be connected to the block's Enable Home input.

Configure the block for Type C counter operation. Enter the Home Count to be loaded into the Accumulator when the Home position is reached.

The operation is as follows:

1. As the conveyor or slide moves toward the reference position, the CPU issues the Home Command (by setting output bit 13 to the High-speed Counter).
2. The Enable Home limit switch is actuated. This informs the High-speed Counter that the next marker pulse will be the reference marker.
3. When the next (reference) marker is reached, the block automatically transfers the Home value to the counter Accumulator.
4. The block informs the CPU that Home position has been found by setting input status bit 3.
5. The CPU may then clear the Home Command (output bit 13), causing the block to remove the Home Found indication.

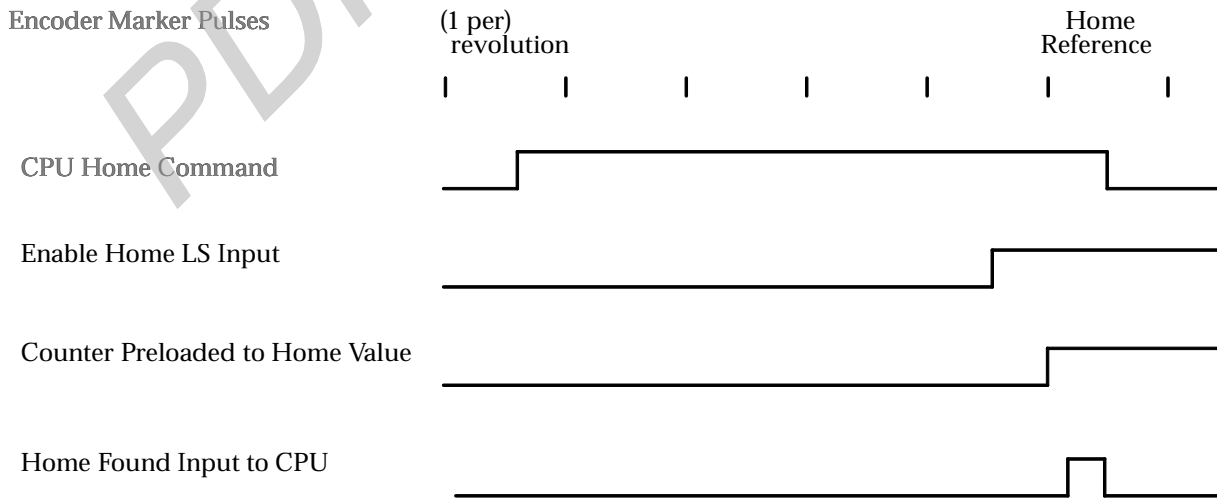

Carousel Tracking

The High-speed Counter can be used to track and retrieve items stored in a rotating carousel, with count inputs being provided to the block by a feedback device coupled to the carousel rotations. The counter limits are configured so that the increments produced by one complete revolution of the carousel cause one full cycle of the counter.

Type C counter configuration is best for this application, since it provides a homing capability. The homing capability makes it possible to synchronize the counter with the carousel position at a defined home location after powerup. From then on, any rotation of the carousel is tracked by the counter. Since the relative location of all entrance and exit points to the Home position is known, the CPU can record the pocket location of each item entering the carousel. It can command any pocket to any exit for item retrieval.

If there are up to 3 entrance points, a different Strobe Input can be used to indicate when a pocket is loaded from each entrance. When the CPU detects the Strobe Set status bit, it can record the pocket position into a memory table and mark it full. (The CPU records the pocket position by reading the value from the Strobe Register, then adding or subtracting the entrance offset from the home location.)

To retrieve an item from a particular exit, the CPU can locate the nearest full pocket to that exit, and generate the required rotation command to the carousel.

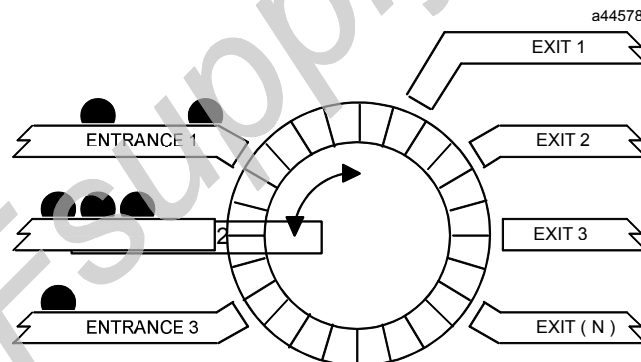

Appendix
B

Oscillator Frequencies

The following table lists the oscillator frequencies, in kHz, that result from all possible configurations of kHz and N. Frequencies that are whole numbers are shown as bold/italics. If the application requires a frequency not in the table, an external oscillator must be used.

PDFsupply.com

B

OSC Frequency	kHz=	N=	OSC Frequency	kHz=	N=	OSC Frequency	kHz=	N=
1360	1360	1	33.17	1360	41	16.79	1360	81
680	1360	2	32.38	1360	42	16.59	1360	82
453.3	1360	3	31.63	1360	43	16.39	1360	83
340	1360	4	30.91	1360	44	16.19	1360	84
272	1360	5	30.22	1360	45	16	1360	85
226.7	1360	6	29.57	1360	46	15.81	1360	86
194.3	1360	7	28.94	1360	47	15.63	1360	87
170	1360	8	28.33	1360	48	15.45	1360	88
	or 170	1		or 170	6		or 170	11
151.1	1360	9	27.76	1360	49	15.28	1360	89
136	1360	10	27.2	1360	50	15.11	1360	90
123.6	1360	11	26.66	1360	51	14.95	1360	91
113.3	1360	12	26.15	1360	52	14.78	1360	92
104.6	1360	13	25.66	1360	53	14.62	1360	93
97.14	1360	14	25.19	1360	54	14.47	1360	94
90.67	1360	15	24.73	1360	55	14.32	1360	95
85	1360	16	24.29	1360	56	14.17	1360	96
	or 170	2		or 170	7		or 170	12
80	1360	17	23.86	1360	57	14.02	1360	97
75.56	1360	18	23.45	1360	58	13.88	1360	98
71.58	1360	19	23.05	1360	59	13.74	1360	99
68	1360	20	22.67	1360	60	13.6	1360	100
64.76	1360	21	22.30	1360	61	13.47	1360	101
61.82	1360	22	21.30	1360	62	13.33	1360	102
59.13	1360	23	21.59	1360	63	13.20	1360	103
56.67	1360	24	21.25	1360	64	13.08	1360	104
	or 170	3		or 170	8		or 170	13
54.4	1360	25	20.92	1360	65	12.95	1360	105
52.31	1360	26	20.61	1360	66	12.83	1360	106
50.37	1360	27	20.30	1360	67	12.71	1360	107
48.54	1360	28	20	1360	68	12.59	1360	108
46.90	1360	29	19.71	1360	69	12.48	1360	109
45.33	1360	30	19.43	1360	70	12.36	1360	110
43.87	1360	31	19.12	1360	71	12.25	1360	111
42.5	1360	32	18.89	1360	72	12.14	1360	112
	or 170	4		or 170	9		or 170	14
41.21	1360	33	18.63	1360	73	12.04	1360	113
40	1360	34	18.38	1360	74	11.93	1360	114
38.86	1360	35	18.13	1360	75	11.83	1360	115
37.78	1360	36	17.90	1360	76	11.72	1360	116
36.76	1360	37	17.66	1360	77	11.62	1360	117
35.79	1360	38	17.44	1360	78	11.53	1360	118
34.87	1360	39	17.22	1360	79	11.43	1360	119
34	1360	40	17	1360	80	11.33	1360	120
	or 170	5		or 170	10		or 170	15

OSC Frequency	kHz=	N=
11.24	1360	121
11.15	1360	122
11.06	1360	123
10.97	1360	124
10.88	1360	125
10.79	1360	126
10.71	1360	127
10.63	1360	128
	or 170	16
	or 10.625	1
10.54	1360	129
10.46	1360	130
10.38	1360	131
10.30	1360	132
10.23	1360	133
10.15	1360	134
10.07	1360	135
10	1360	136
	or 170	17
9.927	1360	137
9.855	1360	138
9.784	1360	139
9.714	1360	140
9.645	1360	141
9.578	1360	142
9.511	1360	143
9.444	1360	144
	or 170	18
9.379	1360	145
9.315	1360	146
9.251	1360	147
9.189	1360	148
9.128	1360	149
9.067	1360	150
9.007	1360	151
8.947	1360	152
	or 170	19
8.889	1360	153
8.831	1360	154
8.774	1360	155
8.718	1360	156
8.662	1360	157
8.608	1360	158
8.553	1360	159
8.5	1360	160
	or 170	20

OSC Frequency	kHz=	N=
8.447	1360	161
8.395	1360	162
8.344	1360	163
8.293	1360	164
8.242	1360	165
8.193	1360	166
8.144	1360	167
8.095	1360	168
	or 170	21
8.047	1360	169
8	1360	170
7.953	1360	171
7.907	1360	172
7.861	1360	173
7.816	1360	174
7.771	1360	175
7.727	1360	176
	or 170	22
7.684	1360	177
7.640	1360	178
7.598	1360	179
7.556	1360	180
7.514	1360	181
7.473	1360	182
7.432	1360	183
7.391	1360	184
	or 170	23
7.351	1360	185
7.312	1360	186
7.272	1360	187
7.234	1360	188
7.196	1360	189
7.158	1360	190
7.120	1360	191
7.083	1360	192
	or 170	24
7.047	1360	193
7.010	1360	194
6.974	1360	195
6.939	1360	196
6.904	1360	197
6.869	1360	198
6.834	1360	199
6.8	1360	200
	or 170	25

OSC Frequency	kHz=	N=
6.766	1360	201
6.733	1360	202
6.700	1360	203
6.667	1360	204
6.634	1360	205
6.602	1360	206
6.570	1360	207
6.539	1360	208
	or 170	26
6.507	1360	209
6.476	1360	210
6.445	1360	211
6.415	1360	212
6.385	1360	213
6.355	1360	214
6.326	1360	215
6.296	1360	216
	or 170	27
6.267	1360	217
6.239	1360	218
6.210	1360	219
6.182	1360	220
6.154	1360	221
6.126	1360	222
6.099	1360	223
6.071	1360	224
	or 170	28
6.044	1360	225
6.018	1360	226
5.991	1360	227
5.965	1360	228
5.939	1360	229
5.913	1360	230
5.884	1360	231
5.862	1360	232
	or 170	29
5.837	1360	233
5.812	1360	234
5.787	1360	235
5.763	1360	236
5.738	1360	237
5.714	1360	238
5.690	1360	239
5.667	1360	240
	or 170	30

B

OSC Frequency	kHz=	N=
5.643	1360	241
5.620	1360	242
5.597	1360	243
5.574	1360	244
5.551	1360	245
5.529	1360	246
5.506	1360	247
5.484	1360	248
	or 170	31
5.462	1360	249
5.44	1360	250
5.418	1360	251
5.397	1360	252
5.376	1360	253
5.354	1360	254
5.333	1360	255
5.313	170	32
	or 10.625	2
5.151	170	33
5	170	34
4.857	170	35
4.722	170	36
4.595	170	37
4.478	170	38
4.359	170	39
4.25	170	40
4.146	170	41
4.048	170	42
3.954	170	43
3.864	170	44
3.778	170	45
3.696	170	46
3.617	170	47
3.542	170	48
	or 10.635	3
3.470	170	49
3.5	170	50
3.333	170	51
3.269	170	52
3.208	170	53
3.148	170	54
3.091	170	55
3.036	170	56

OSC Frequency	kHz=	N=
2.982	170	57
2.931	170	58
2.881	170	59
2.833	170	60
2.787	170	61
2.742	170	62
2.698	170	63
2.656	170	64
	or 10.625	4
2.615	170	65
2.576	170	66
2.537	170	67
2.5	170	68
2.464	170	69
2.429	170	70
2.394	170	71
2.361	170	72
2.329	170	73
2.297	170	74
2.267	170	75
2.237	170	76
2.208	170	77
2.180	170	78
2.152	170	79
2.125	170	80
	or 10.625	5
2.099	170	81
2.073	170	82
2.048	170	83
2.024	170	84
2	170	85
1.977	170	86
1.954	170	87
1.932	170	88
1.910	170	89
1.889	170	90
1.868	170	91
1.848	170	92
1.828	170	93
1.809	170	94
1.790	170	95
1.771	170	96
	or 10.625	6

OSC Frequency	kHz=	N=
1.753	170	97
1.735	170	98
1.717	170	99
1.7	170	100
1.683	170	101
1.667	170	102
1.651	170	103
1.635	170	104
1.619	170	105
1.604	170	106
1.589	170	107
1.574	170	108
1.560	170	109
1.545	170	110
1.532	170	111
1.518	170	112
	or 10.625	7
1.504	170	113
1.491	170	114
1.478	170	115
1.466	170	116
1.453	170	117
1.441	170	118
1.429	170	119
1.417	170	120
1.405	170	121
1.393	170	122
1.382	170	123
1.371	170	124
1.36	170	125
1.349	170	126
1.339	170	127
1.328	170	128
	or 10.625	8
1.318	170	129
1.308	170	130
1.298	170	131
1.288	170	132
1.278	170	133
1.269	170	134
1.259	170	135
1.25	170	136

OSC Frequency	kHz=	N=
1.241	170	137
1.232	170	138
1.223	170	139
1.214	170	140
1.206	170	141
1.197	170	142
1.189	170	143
1.181	170	144
	or 10.625	9
1.172	170	145
1.164	170	146
1.157	170	147
1.149	170	148
1.141	170	149
1.133	170	150
1.126	170	151
1.118	170	152
1.111	170	153
1.104	170	154
1.097	170	155
1.090	170	156
1.083	170	157
1.076	170	158
1.069	170	159
1.063	170	160
	or 10.625	10
1.056	170	161
1.049	170	162
1.043	170	163
1.037	170	164
1.030	170	165
1.024	170	166
1.018	170	167
1.012	170	168
1.006	170	169
<i>I</i>	170	170
.9942	170	171
.9884	170	172
.9827	170	173
.9770	170	174
.9714	170	175
.9659	170	176
	or 10.625	11

OSC Frequency	kHz=	N=
.9605	170	177
.9551	170	178
.9407	170	179
.9444	170	180
.9392	170	181
.9341	170	182
.9290	170	183
.9239	170	184
.9189	170	185
.9140	170	186
.9091	170	187
.9043	170	188
.8995	170	189
.8947	170	190
.8901	170	191
.8854	170	192
	or 10.625	12
.8808	170	193
.8763	170	194
.8718	170	195
.8674	170	196
.8629	170	197
.8586	170	198
.8543	170	199
.85	170	200
.8458	170	201
.8416	170	202
.8374	170	203
.8333	170	204
.8293	170	205
.8252	170	206
.8213	170	207
.8173	170	208
	or 10.625	13
.8134	170	209
.8095	170	210
.8057	170	211
.8019	170	212
.7981	170	213
.7944	170	214
.7907	170	215
.7870	170	216

OSC Frequency	kHz=	N=
.7834	170	217
.7798	170	218
.7763	170	219
.7727	170	220
.7692	170	221
.7658	170	222
.7623	170	223
.7589	170	224
	or 10.625	14
.7556	170	225
.7522	170	226
.7489	170	227
.7456	170	228
.7424	170	229
.7391	170	230
.7359	170	231
.7328	170	232
.7296	170	233
.7265	170	234
.7234	170	235
.7203	170	236
.7173	170	237
.7143	170	238
.7113	170	239
.7083	170	240
	or 10.625	15
.7054	170	241
.7025	170	242
.6996	170	243
.6967	170	244
.6939	170	245
.6911	170	246
.6883	170	247
.6855	170	248
.6827	170	249
.68	170	250
.6773	170	251
.6746	170	252
.6719	170	253
.6693	170	254
.6667	170	255

B

For the following OSC frequencies, configure 10.625kHz with the correct value of N.

OSC Frequency	N=	OSC Frequency	N=	OSC Frequency	N=	OSC Frequency	N=	OSC Frequency	N=	OSC Frequency	N=
.6641	16	.1771	60	.1022	104	.07179	148	.05534	192	.04502	236
.625	17	.1742	61	.1012	105	.07131	149	.05505	193	.04483	237
.5903	18	.1714	62	.1002	106	.07083	150	.05477	194	.04464	238
.5592	19	.1687	63	.09930	107	.07036	151	.05449	195	.04446	239
.5313	20	.1661	64	.09838	108	.06990	152	.05421	196	.04427	240
.5060	21	.1635	65	.09748	109	.06944	153	.05393	197	.04409	241
.4830	22	.1610	66	.09659	110	.06899	154	.05366	198	.04390	242
.4620	23	.1586	67	.09572	111	.06855	155	.05339	199	.04392	243
.4427	24	.1563	68	.09487	112	.06811	156	.05313	200	.04355	244
.425	25	.1540	69	.09403	113	.06768	157	.05286	201	.04337	245
.4087	26	.1518	70	.09320	114	.06725	158	.05260	202	.04319	246
.3935	27	.1497	71	.09239	115	.06682	159	.05234	203	.04302	247
.3795	28	.1476	72	.09159	116	.06641	160	.05208	204	.04284	248
.3664	29	.1456	73	.09081	117	.06599	161	.05183	205	.04267	249
.3542	30	.1436	74	.09004	118	.06559	162	.05158	206	.0425	250
.3427	31	.1417	75	.08929	119	.06518	163	.05133	207	.04233	251
.3320	32	.1398	76	.08854	120	.06479	164	.05108	208	.04216	252
.3220	33	.1380	77	.08781	121	.06439	165	.05084	209	.04200	253
.3125	34	.1362	78	.08709	122	.06401	166	.05060	210	.04183	254
.3036	35	.1345	79	.08638	123	.06362	167	.05036	211	.04167	255
.2951	36	.1328	80	.08569	124	.06324	168	.05012	212		
.2872	37	.1312	81	.085	125	.06287	169	.04988	213		
.2796	38	.1296	82	.08433	126	.0625	170	.04965	214		
.2724	39	.1280	83	.08376	127	.06213	171	.04942	215		
.2656	40	.1265	84	.08301	128	.06177	172	.04919	216		
.2592	41	.125	85	.08236	129	.06142	173	.04896	217		
.2530	42	.1236	86	.08173	130	.06106	174	.04874	218		
.2471	43	.1221	87	.08111	131	.06071	175	.04852	219		
.2415	44	.1207	88	.08049	132	.06037	176	.04830	220		
.2361	45	.1194	89	.07989	133	.06003	177	.04808	221		
.2310	46	.1181	90	.07929	134	.05969	178	.04786	222		
.2261	47	.1168	91	.07870	135	.05936	179	.04765	223		
.2214	48	.1155	92	.07813	136	.05903	180	.04743	224		
.2168	49	.1143	93	.07755	137	.05870	181	.04722	225		
.2125	50	.1130	94	.07699	138	.05838	182	.04701	226		
.2083	51	.1118	95	.07644	139	.05806	183	.04681	227		
.2043	52	.1107	96	.07589	140	.05774	184	.04660	228		
.2005	53	.1095	97	.07535	141	.05743	185	.04640	229		
.1968	54	.1084	98	.07482	142	.05712	186	.04620	230		
.1932	55	.1073	99	.07430	143	.05682	187	.04600	231		
.1897	56	.1063	100	.07378	144	.05652	188	.04580	232		
.1864	57	.1052	101	.07328	145	.05622	189	.04560	233		
.1822	58	.1042	102	.07277	146	.05592	190	.04541	234		
.1801	59	.1032	103	.07228	147	.05563	191	.04521	235		

A

A and B inputs, 1-13 , 1-19
 A-Quad-B counting, 1-16 , 1-17 , 1-22
 configuring block for, 3-17
 AC block power, 2-5
 AC block power with DC backup, 2-6
 Accumulator, 1-7 , 1-8
 adjustment, 1-11 , 1-14 , 1-20
 change value temporarily, 1-25 , 6-10
 data sent to CPU, 5-7 , 5-11 , 5-14
 display value on HHM, 1-26 , 4-6
 for Type A block, 1-9 , 1-11
 for Type B block, 1-12 , 1-14 , 5-11
 for Type C block, 1-18 , 1-19 , 5-14
 linked to strobe registers, 3-11
 register, for Type A block, 1-9
 Active block, on HHM display, 4-2

B

Baud rate configuration, 1-24 , 3-2 , 3-7
 Block ID number configuration, 1-24 , 3-1 ,
 3-5
 Block power, 1-1 , 1-2 , 2-5
 Block type
 configuration with HHM, 3-1
 in configuration datagram, 6-2
 Type A, description, 1-9
 Type B, description, 1-12
 Type C, description, 1-17
 Block wiring, 2-3
 Bus
 connection, 2-4
 number of blocks, Series Six, 5-4
 termination, 2-4

C

Carousel tracking, A-21
 Cascading counters, A-7
 Catalog number, 1-2 , 6-2
 Clear error output for Type C block, 1-7
 Clear error outputs for Type C block, 5-17
 Clear output faults, 1-26 , 4-8

Compatibility, 1-3 , 2-1
 Computer, host, data handling, 5-6
 Configuration, 1-8 , 1-24 , 3-1
 change temporarily, 1-25 , 3-2
 change with datagram, 6-2
 datagram format, 6-2
 for Type A block, 6-4
 for Type B block, 6-5
 for Type C block, 6-6
 parameters, additional, 3-2
 parameters, required, 3-1
 preventing changes, 1-24 , 3-2
 read with datagram, 6-2
 Continuous counting configuration, 1-24 ,
 3-18
 Control Inputs, 1-4
 Control-signal generator, wiring to block,
 2-16
 Conveyor control, A-16
 Count
 direction, 1-9 , 1-17 , 1-24
 change temporarily, 1-25 , 6-10
 configuration, 3-16
 doubling, A-5
 input, 1-11
 limits
 change temporarily, 1-25 , 6-10
 configuration, 1-24 , 3-2 , 3-20
 configuration error, Type A block, 5-7
 configuration error, Type B block, 5-11

 configuration error, Type C block, 5-14

 mode configuration, 3-2 , 3-17
 rate, 1-2
 Counter inputs, 1-4 , 1-8
 for Type A block, 1-10
 for Type B block, 1-13
 for Type C block, 1-19
 Counter operation, 1-8
 configuring, 3-2
 for Type A block, 1-9
 for Type B block, 1-12
 for Type C block, 1-17
 Counter preloading, 1-8 , A-20
 Counter timebase, 1-8
 changing temporarily, 1-25 , 6-10
 configuration, 1-24 , 3-2 , 3-19
 Counter type configuration, 1-24 , 3-5

Counters, number of
for Type A block, 1-9
for Type B block, 1-12
for Type C block, 1-18

Counts per timebase, 1-7 , 1-8 , 4-6
display preset value on HHM, 1-26
for Type A block, 1-9 , 5-7
for Type B block, 1-12 , 5-11
for Type C block, 1-18 , 5-14
register
for Type A block, 1-11
for Type B block, 1-14
for Type C block, 1-20

CPU Redundancy, 1-24 , 3-2 , 3-25

Current values, display, 4-6

Cycletime, I/O, 1-6

D

Data transfer, 5-2

Datagrams, 1-8
data formats for configuration, 6-1 , 6-2
data formats for diagnostics, 6-1 , 6-7
supported by High-speed Counter, 6-1
using to change data temporarily, 6-1 ,
6-8

Datasheet, publication number, 1-2

DC block power, 2-6

DC output, +5V, 1-6 , 2-6 , 2-7
using to power open-collector input
device, 2-18

Device number configuration, 1-24 , 3-5

Diagnostics data format, 6-7

Differential counting, 1-23

Differential speeds, A-2

Direction-dependent positioning, A-3

Disable input, 1-4 , 1-13 , 1-19
display on HHM, 1-26 , 4-4
for Type B block, 1-14
for Type C block, 1-19
status bit, for Type B block, 5-12
status bit for Type C block, 5-15

E

Enable Home input, 1-18 , 1-19
display on HHM, 4-4

Enable Output bits, 1-9
for Type A block, 5-9
for Type B block, 5-13
for Type C block, 5-16

Encoders, connecting to block, 2-16

Error, status bit
for Type A block, 5-9
for Type C block, 5-14

Error, status bit, 1-7
for Type B block, 5-12

F

Factory Mutual installations, fusing re-
quired, 2-5

Failed Switch diagnostic, 1-6 , 4-8

Fault clearing, 1-26 , 4-8

Field wiring, 2-8

Forcing outputs, 1-6 , 4-10

G

Grounding, 2-2

H

Hand-held Monitor, 1-24 , 1-26
attaching to block, 3-4
using for block configuration, 3-1
using to monitor block operation, 4-1
version required, 1-3 , 3-3

Home Found marker, 5-15

Home input, 1-4

Home position, 3-23
configuration, 1-24 , 3-2 , 3-23
Enable Home input, 1-18
Enable Home input, display on HHM,
1-26
Home command, 1-7 , 5-16
Home error, 5-14
Home Found marker, 1-19 , A-20

Home Found status bit, 5-15

Host computer, data handling, 5-6

I

Input filters, configuration, 3-2

Input thresholds, configuration, 3-2

Input/output cycle time, 1-6

Inputs, from block to host, 1-7 , 5-1
 for Type A block, 5-7
 for Type B block, 5-11
 for Type C block, 5-14

Inputs, to block, 1-8
 A-Quad-B signals, 1-4
 connecting differential, 2-8
 Direction signals, 1-4
 Disable input, 1-4
 display current states on HHM, 4-4
 filter configuration, 1-24 , 3-15
 for Type A block, 1-9
 for Type B block, 1-12
 for Type C block, 1-18
 Home input, 1-4
 Marker input, 1-4
 Preload inputs, 1-4 , 1-8
 Pulse signals, 1-4
 signal levels, 1-4
 Strobe inputs, 1-4 , 1-8
 threshold configuration, 1-24 , 3-10
 wiring encoders to Type C block, 2-16
 wiring for control-signal generator, 2-16
 wiring for TTL open-collector inputs, 2-18
 wiring to Type A block, 2-9 , 2-10
 wiring to Type B block, 2-11 , 2-12
 wiring to Type C block, 2-13 , 2-14 , 2-15

Installation, 2-1
 hardware required, 2-3

L

Latched strobes, configuring, 3-13

LEDs, 1-1 , 1-5

M

Marker input, 1-4

Measuring material length, A-15

Measuring pulse time, A-10

Model number, 6-2

Module Ready status bit, 1-7
 for Type A block, 5-9
 for Type B block, 5-12
 for Type C block, 5-15

Monitoring the block, 1-26 , 4-1

Mounting footprint, 2-1

N

Number of counters, 1-1

O

Open-collector input devices, power for, 2-18

Oscillator output, 1-6 , 2-8
 frequency
 change temporarily, 1-25 , 6-10
 change with datagram, 6-2
 configuration, 1-24 , 3-2 , 3-9
 used as a reference, A-8 , A-10 , A-17 , A-19

Output presets, 1-8 , 1-9

Output status, 5-8 , 5-12 , 5-15

Output, +5 volt DC, 2-8

Outputs, from block, 1-5 , 1-8 , 1-9
 display current states on HHM, 1-26 , 4-3 , 4-9
 enable or disable, 1-7 , 1-24 , 3-2 , 3-8
 for Type A block, 1-9
 for Type B block, 1-12
 for Type C block, 1-18
 forcing, 1-6 , 1-26 , 4-10
 power for, 2-7 , 2-8
 Presets
 configuration, 1-24 , 3-2 , 3-21
 for Type A block, 1-12
 for Type B block, 1-14
 for Type C block, 1-20
 presets, 1-26
 wiring to Type A block, 2-9

wiring to Type B block, 2-11
wiring to Type C block, 2-13

Outputs, from host to block, 1-26
for Type A block, 5-8 , 5-9
for Type B block, 5-13
for Type C block, 5-16

P

Power source connections for outputs, 2-7

Preload, 1-8
change temporarily, 1-25 , 6-10
configuration, 1-24 , 3-2
counters, A-20
input, 1-4 , 1-10 , 1-13 , 1-19
display on HHM, 1-26 , 4-4
register, 1-8
configuring starting count value, 3-24
for Type A block, 1-9 , 1-10
for type B block, 1-13
for Type C block, 1-19
reset bits, 1-7
status bits, 1-8
for Type A block, 5-8 , 5-9
for Type B block, 5-12
for Type C block, 5-15
reset, 5-9 , 5-13 , 5-16

Preset outputs, display, 4-3

Preventing changes, 3-25

Pulse rate measurement, A-8

Pulse test configuration, 1-24 , 3-2 , 3-8

Pulse time, measuring, A-10

Pulse/direction counting, 1-15 , 1-17 , 1-21
configuring block for, 3-17

R

Read configuration with datagram, 6-2

Read Data datagram, 6-9

Read diagnostics data with datagram, 6-7

Reference number configuration, 1-24 ,
3-1 , 3-5

Report faults, configuration, 3-2

Report faults configuration, 3-12

Reset Preload output
for Type A block, 5-9

for Type B block, 5-13
for Type C block, 5-16

Reset Strobe output
for Type A block, 5-9
for Type C block, 5-16

Reset strobe output, for Type B block, 5-13

RPM indicator, A-13

S

Series 90-70 PLC, 5-3

Series Five PLC, 1-3
programming considerations, 5-6

Series Six PLC, 1-3
programming considerations, 5-4

Setup, 1-24

Short circuit protection, 1-6

Single-shot counting configuration, 1-24 ,
3-18

Software revision number, in configura-
tion datagram, 6-2

Status bits, 1-7
for Type A block, 5-8
for Type B block, 5-12
for Type C block, 5-15

Status code
for Type A block, 5-7
for Type B block, 5-11
for Type C block, 5-14

Strobe, 1-8
inputs, 1-4 , 1-11 , 1-14 , 1-20
display on HHM, 1-26 , 4-4
register, 1-7 , 1-8 , 5-11 , 5-14
display value on HHM, 1-26
for Type A block, 1-11 , 5-7 , 5-8
for Type B block, 1-12 , 1-14 , 5-11
for Type C block, 1-18 , 1-20 , 5-15
reset
for Type A block, 5-9
for Type B block, 5-13
for Type C block, 5-16
status bits
for Type A block, 5-8
for Type B block, 5-12
for Type C block, 5-15

Strobe edge configuration, 3-2 , 3-13

Strobe effect, configuration, 3-14

Strobe input, 1-11
 display on HHM, 4-4
Strobe Linkage, 1-24 , 3-11
Strobe Mode configuration, 3-13
Strobe reset bits, 1-7
Strobe value, 4-6

T

Table of configurable frequencies, B-1
Temperature specifications, 1-2
Terminal assignments
 Type A, 2-9
 Type B, 2-11
 Type C, 2-13
Timing diagrams
 for Type A block, 1-11
 for Type B block, 1-15
 for Type C block, 1-21

Timing Pulse generation, A-17
Tolerance checking, A-14

U

Up/down counting, 1-9 , 1-13 , 1-15 , 1-17 ,
 1-21
 configuring block for, 3-17

V

Velocity control, A-19
VL+ terminal, connecting, 2-7

W

Wiring, 2-3
Write Data datagram, 6-10