

IC693ALG220
New In Stock!
GE Fanuc

<http://www.pdfsupply.com/automation/ge-fanuc/series-90-30/IC693ALG220>

Series 90-30
1-919-535-3180

In Stock! Analog Input 4 Ch IC693A IC693AL IC693ALG

www.pdfsupply.com

Email: sales@pdfsupply.com

Scaling of the input is shown below in Figure 3-11.

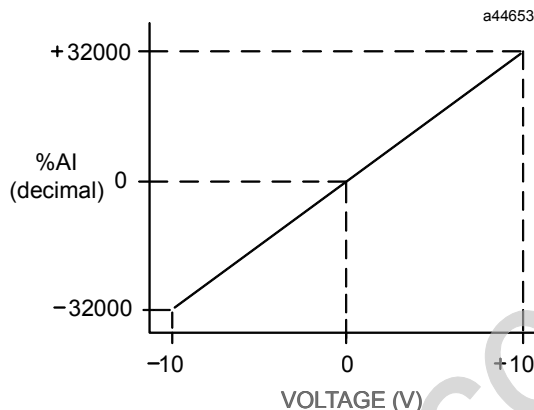

Figure 10-2. Scaling for Voltage Input

A limited current input mode is also provided in the module. A jumper is provided on the user terminal connector for each channel, which may be used to connect the internal 250 ohm shunt resistor into the circuit. The shunt resistor effectively provides a -40 to +40 mA current input range. However, the input current should generally not exceed ± 20 mA, to avoid self-heating of the input resistor and a corresponding loss of accuracy. A 4 to 20 mA input corresponds to a 1 to 5 volt input to the voltage input module; therefore, the resolution of the 4 to 20 mA input signal is approximately 10 bits binary (1 part in 1024). The resolution can be increased to approximately 11 bits (1 part in 2048) by using a precision 250 ohm resistor in place of the jumper. The resistor causes the voltage input module to see a 4 to 20 mA input as 2 to 10 volts.

The main power source for the module is derived from the isolated +24 VDC power supplied by the PLC power supply. This voltage is routed through an inverter/regulator to produce the operating voltages for the module. This module also consumes 27 mA from the +5 VDC output of the PLC power supply. An LED at the top of the module's faceplate is ON when the module's power supply is operating. The module provides electrical isolation of externally generated noise between the field wiring and the backplane through optical isolation.

To minimize the capacitive loading and noise, all field connections to the module should be wired using a good grade of twisted, shielded instrumentation cable. The shields can be connected to either COM or GND. The COM connection provides access to the common of the analog circuitry in the module. The GND connection provides access to the baseplate (frame ground).

This module can be installed in any I/O slot of a 5 or 10-slot baseplate in a Series 90-30 PLC system. See page 3-11 to determine the number of Analog Voltage Input modules that can be installed in a system.

Note

Connect the + and - terminals together for all unused inputs in order to minimize any fluctuations in the analog input table for the unused points.

Table 10-1. Specifications for Analog Voltage Input Module - IC693ALG220

Voltage Range	-10 to +10 volts †
Calibration	Factory calibrated
Update Rate	4 msec (all four channels)
Resolution	5 mV/20 µA, (1 LSB = 5 mV)
Absolute Accuracy ‡	±10 mV/40 µA (typical) over operating temperature ±30 mV/160 µA (maximum) over operating temperature
Linearity	< 1 Least Significant Bit
Isolation	1500 volts between field side and logic side
Cross-Channel Rejection	> 80 db
Input Impedance	> 9 Megohms (voltage mode) 250 ohms (current mode)
Input Filter Response	17 Hz
Internal Power Consumption	27 mA from +5 volt bus on the backplane 98 mA from the isolated +24 volt backplane bus

Refer to Appendix C for product standards and general specifications.

† Both inputs must be within ± 11 volts of COM, including any noise present on the inputs.

‡ In the presence of severe RF interference (IEC 801-3, 10V/m), accuracy may be degraded to ±100 mV/400 µA.

Analog Voltage Input Block Diagram

The following figure is a block diagram of the 4-Channel Analog Voltage Input Module.

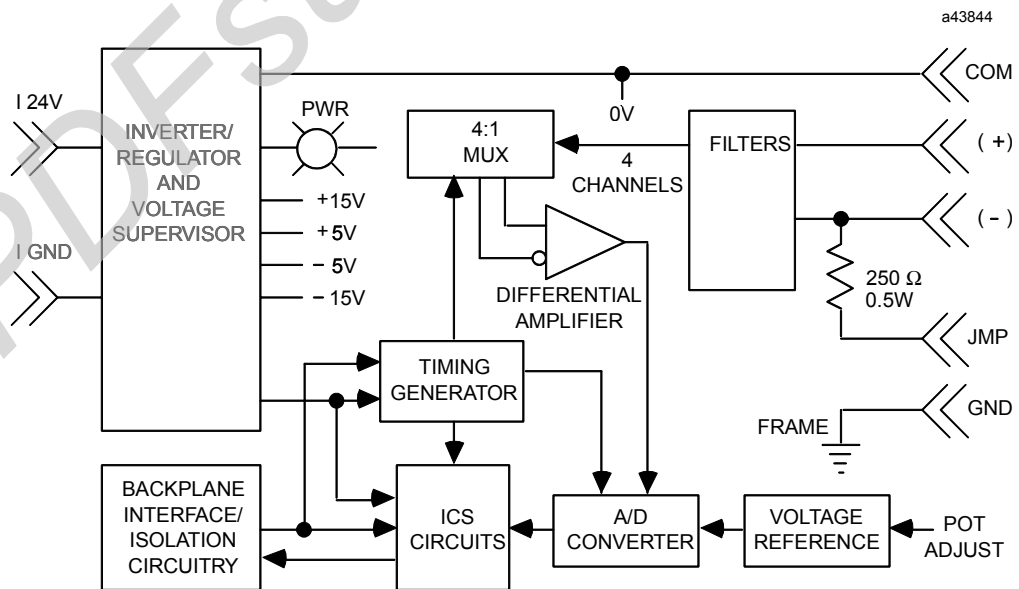

Figure 10-3. Analog Voltage Input Module Block Diagram for IC693ALG220

IC693ALG220 Analog Input Module Field Wiring Information

The following figure provides information for connecting field wiring to the 4-Channel Analog Voltage Input module.

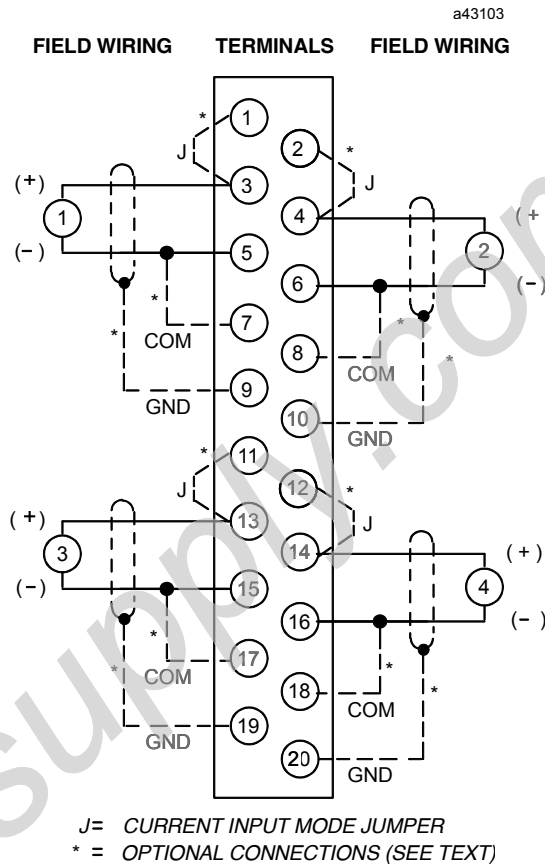

Figure 10-4. Field Wiring for 4-Channel Analog Voltage Input Module

Note

The (-) side of the voltage source can also be tied to the COM terminal if the source is floating to limit common-mode voltages. The COM connection provides access to the common of the analog circuitry in the module. The GND connection provides access to the baseplate (frame ground).

Please refer to Chapter 2 for wiring and shield ground connection details.