

IC693ALG390
New In Stock!
GE Fanuc

<http://www.pdfsupply.com/automation/ge-fanuc/series-90-30/IC693ALG390>

Series 90-30
1-919-535-3180

In Stock! Analog Output 2PT IC693A IC693AL IC693ALG

www.pdfsupply.com

Email: sales@pdfsupply.com

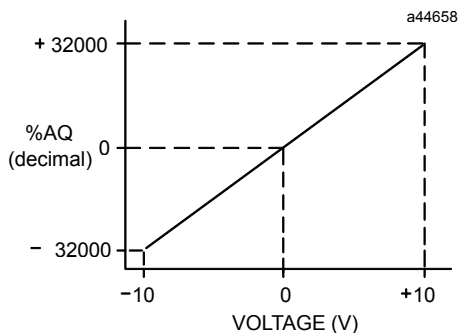

Figure 11-2. Scaling for Voltage Output

The primary power source for the module is the isolated +24 VDC power supplied by the PLC power supply. Two terminals are provided on the module’s terminal connector for user supplied +24 volts. This allows you to provide a standby power supply, so that the outputs can continue to hold their value if the internal supply is lost and Hold Last State is selected. Additionally, you can also supply the module voltage to reduce the load on the PLC isolated +24 VDC power supply. The user supply must be used when the applied voltage is 0.7 volts higher than the isolated +24 VDC supply, which can range from 21.5 volts to 26.5 volts. An LED at the top of the module’s faceplate is ON when the module’s power supply is operating.

To minimize capacitive loading and noise, all field connections should be wired using a good grade of twisted, shielded instrumentation cable. The shields should be connected to GND on the user terminal connector block. The GND connection provides access to the baseplate (frame ground) resulting in superior rejection of noise caused by any shield drain currents.

The module provides electrical isolation of externally generated noise between field wiring and the backplane through the use of optical isolation. This module can be installed in any I/O slot of a 5 or 10-slot baseplate in a Series 90-30 PLC system. Refer to page 3-11 to determine the number of Analog Voltage Output modules that can be installed in a system.

Table 11-1. Specifications for Analog Voltage Output Module, IC693ALG390

Voltage Range	-10 to +10 volts
Calibration	Factory calibrated to 2.5 mV per count
Supply Voltage (nominal)	+24 VDC, from isolated +24 VDC on backplane or user supplied voltage source, and +5 VDC from backplane
External Supply Voltage Range	18 to 30 VDC
External Supply Voltage Ripple	10%
Update Rate	5 msec (both channels) <i>This update rate is approximate since it is determined by I/O scan time, and is application dependent.</i>
Resolution	2.5 mV (1 LSB = 2.5 mV)
Absolute Accuracy †	± 5 mV at 25° C (77° F)
Offset	1 mv maximum, 0 to 60° C (32° to 140° F)
Output Loading (maximum)	5 mA (2K ohms minimum resistance)
Output Load Capacitance	2000 pico farads, maximum
Isolation	1500 volts between field side and logic side
Internal Power Consumption	32 mA from +5 volt supply 120 mA from +24 volt supply (isolated backplane or user supply)

Refer to Appendix B for product standards and general specifications.

† In the presence of severe RF interference (IEC 801-3, 10V/m), accuracy may be degraded to ±50mV.

IC693ALG390 Analog Voltage Output Block Diagram

The following figure is a block diagram of the 2-Channel Analog Voltage Output Module, IC693ALG390.

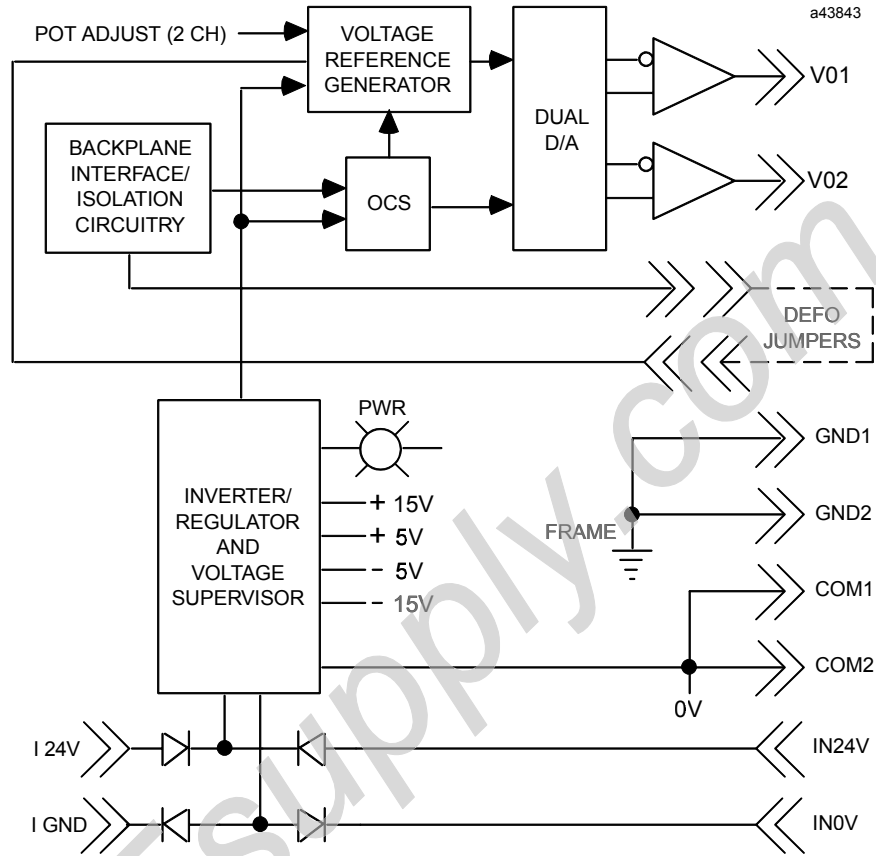

Figure 11-3. Analog Voltage Output Module Block Diagram - IC693ALG390

IC693ALG390 Analog Output Module Field Wiring Diagram

The following figure provides information for connecting field wiring to the Analog Voltage Output module.

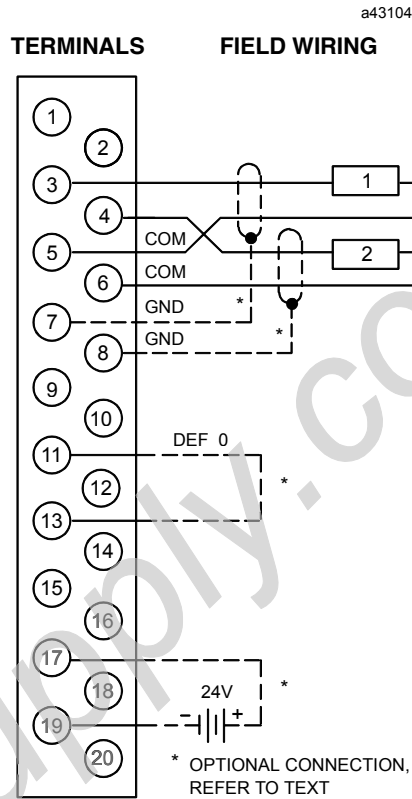

Figure 11-4. Field Wiring for Analog Voltage Output Module - IC693ALG390

Note

Please refer to Chapter 2 for wiring and shield ground connection details.