

**IC693ALG391**  
**New In Stock!**  
**GE Fanuc**

<http://www.pdfsupply.com/automation/ge-fanuc/series-90-30/IC693ALG391>

**Series 90-30**  
**1-919-535-3180**

In Stock! Analog Output Current IC693A IC693AL IC693ALG

[www.pdfsupply.com](http://www.pdfsupply.com)

Email: [sales@pdfsupply.com](mailto:sales@pdfsupply.com)

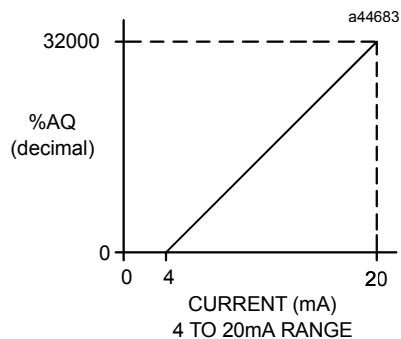

Figure 11-7. Scaling for Current Output, 4 to 20 mA

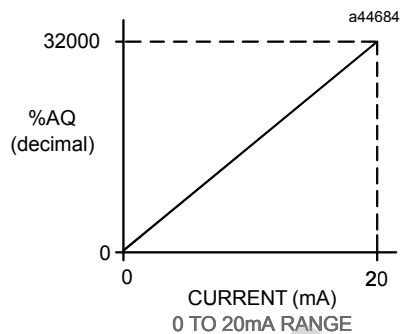

Figure 11-8. Scaling for Current Output, 0 to 20 mA

The state of the module if the CPU goes to the STOP mode or RESET, can be either *Default to 0/4 mA* or *Hold-Last-State*. Selection of the desired state is made by configuring the DEF0/4 jumper on the detachable terminal board connector on the module. If the jumper is not installed, the outputs will Hold-Last-State on STOP or RESET provided that a backup user supply is connected when the system power goes down. If the DEF0/4 jumper is present, the module defaults to 4 mA on the 4 to 20 mA range or 0 mA on the 0 to 20 mA range on STOP or RESET. One jumper per module is used to program both outputs for Hold-Last-State or DEF0/4.

Each module output may be used as a current source or as a less accurate voltage source. A voltage is output at VOUTx that corresponds to the current output. The selection of current or voltage output is made with a jumper on the I/O terminal board. If no jumper is installed, the module performs as a current source. If the JMPVx jumper is present, the module performs as a voltage source. Each channel has the option of selecting voltage or current. The setting of the current output range determines the voltage range. The voltage range can be increased by using a 250 ohm resistor in place of the voltage jumper from JMPVx to IOUtx. The following table shows the relationship between range settings and voltage outputs.

Table 11-2. Range Settings vs. Voltage Outputs

Range Setting	Voltage Range
4 to 20 mA (no range jumper)	1 to 5 V 2 to 10 V with external resistor
0 to 20 mA (range jumper present)	0 to 5 V 0 to 10 V with external resistor

The primary power source for the module is the isolated +24 VDC power supplied by the PLC power supply. Two terminals are also provided on the module's I/O terminal board for user supplied +24 volts. This allows you to provide a standby power supply so that the outputs can continue to hold their value if the internal supply is lost and Hold-Last-State is selected. You may also want to supply the module voltage to reduce the load on the PLC isolated +24 VDC power supply. The user supply will be used when the applied voltage is higher than the isolated +24 VDC supply, which can range from 21.5 volts to 26.5 volts.

An internal voltage source of about +24V is generated in the module to drive the current loop outputs. The current loop drivers on the module are source type drivers. This means that a positive current flows out of the current loop outputs so that the user's loads can be returned to common. A resistor is placed in series with the common return to limit ground loop currents. To minimize the

capacitive loading and noise, all field connections to the module should be wired using a good grade of twisted, shielded instrumentation cable. The shields should be connected to GND on the user terminal connector block. The GND connection provides access to the baseplate (frame ground) resulting in superior rejection of noise caused by any shield drain currents.

An LED on the module's faceplate is ON when the module's power supply is operating. The module provides electrical isolation of externally generated noise between field wiring and the backplane through use of optical isolation. This module can be installed in any I/O slot of a 5 or 10-slot baseplate in a Series 90-30 PLC system. If user provided supplies are not used to power the module, a maximum of three Analog Current Output modules can be installed in a baseplate.

**Table 11-3. Specifications for Analog Current Output Module - IC693ALG391**

<b>Output Current Range</b>	4 to 20 mA and 0 to 20 mA
<b>Output Voltage Range <sup>1</sup></b>	1 to 5 V and 0 to 5 V
<b>Calibration</b>	Factory calibrated to 4µA per count
<b>Supply Voltage (nominal)</b>	+24 VDC, from isolated +24 VDC on backplane or user supplied voltage source, and +5 VDC from backplane
<b>External Supply Voltage Range <sup>2</sup></b>	20 to 30 VDC
<b>External Supply Voltage Ripple</b>	10%
<b>Update Rate</b>	5 msec (approximate, both channels) <i>Determined by I/O scan time, and is application dependent.</i>
<b>Resolution:</b>	
<b>4 to 20 mA</b>	4µA (1 LSB = 4µA)
<b>0 to 20 mA</b>	5µA (1 LSB = 5µA)
<b>1 to 5 V</b>	1 mV (1 LSB = 1 mV)
<b>0 to 5 V</b>	1.25 mV (1 LSB = 1.25 mV)
<b>Absolute Accuracy: <sup>3</sup></b>	
<b>4 to 20 mA</b>	±8µA at 25°C (77°F)
<b>0 to 20 mA</b>	±10µA at 25°C (77°F)
<b>1 to 5 V</b>	±50 mV at 25°C (77°F)
<b>0 to 5 V</b>	±50 mV at 25°C (77°F)
<b>Maximum Compliance Voltage</b>	25 V
<b>User Load (current mode)</b>	0 to 850 ohms
<b>Output Load Capacitance (current mode)</b>	2000 pF
<b>Output Load Inductance (current mode)</b>	1 H
<b>Maximum Output Loading (voltage mode)</b>	5 mA (2K ohms minimum resistance) (2000 pF maximum capacitance)
<b>Isolation</b>	1500 volts between field and logic side
<b>Internal Power Consumption</b>	30 mA from +5V supply 215 mA from Isolated +24 VDC backplane supply or user supply

**Refer to Appendix B for product standards and general specifications.**

<sup>1</sup> Allowable load on the voltage output option can be calculated from the total module current shown in Figure 3-38.

<sup>2</sup> Allowable user supply is dependent on the current load and the ambient temperature as shown in Figure 3-38.

<sup>3</sup> In the presence of severe RF interference (IEC 801-3, 10V/m), accuracy may be degraded to 2 µA (4 to 20 mA range), 2 µA (0 to 20 mA range).

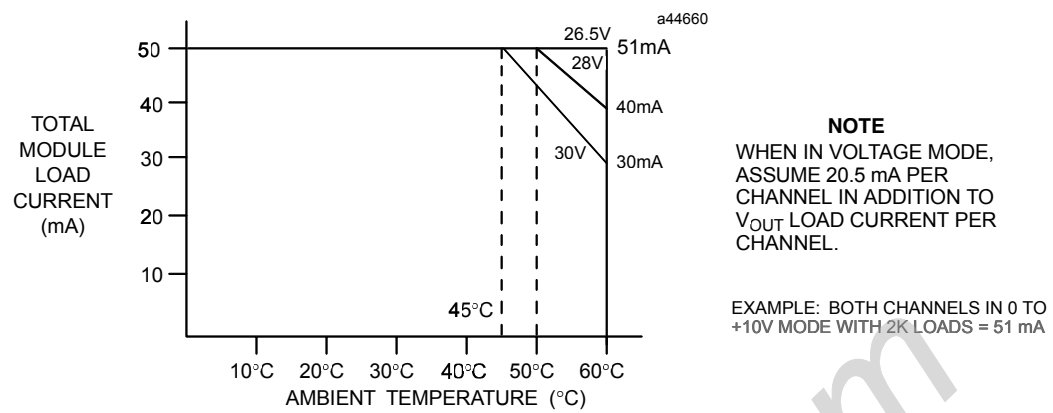

Figure 11-9. Load Current Derating

### IC693ALG391 Analog Current Output Block Diagram

The following figure is a block diagram of the 2-channel Analog Output module.

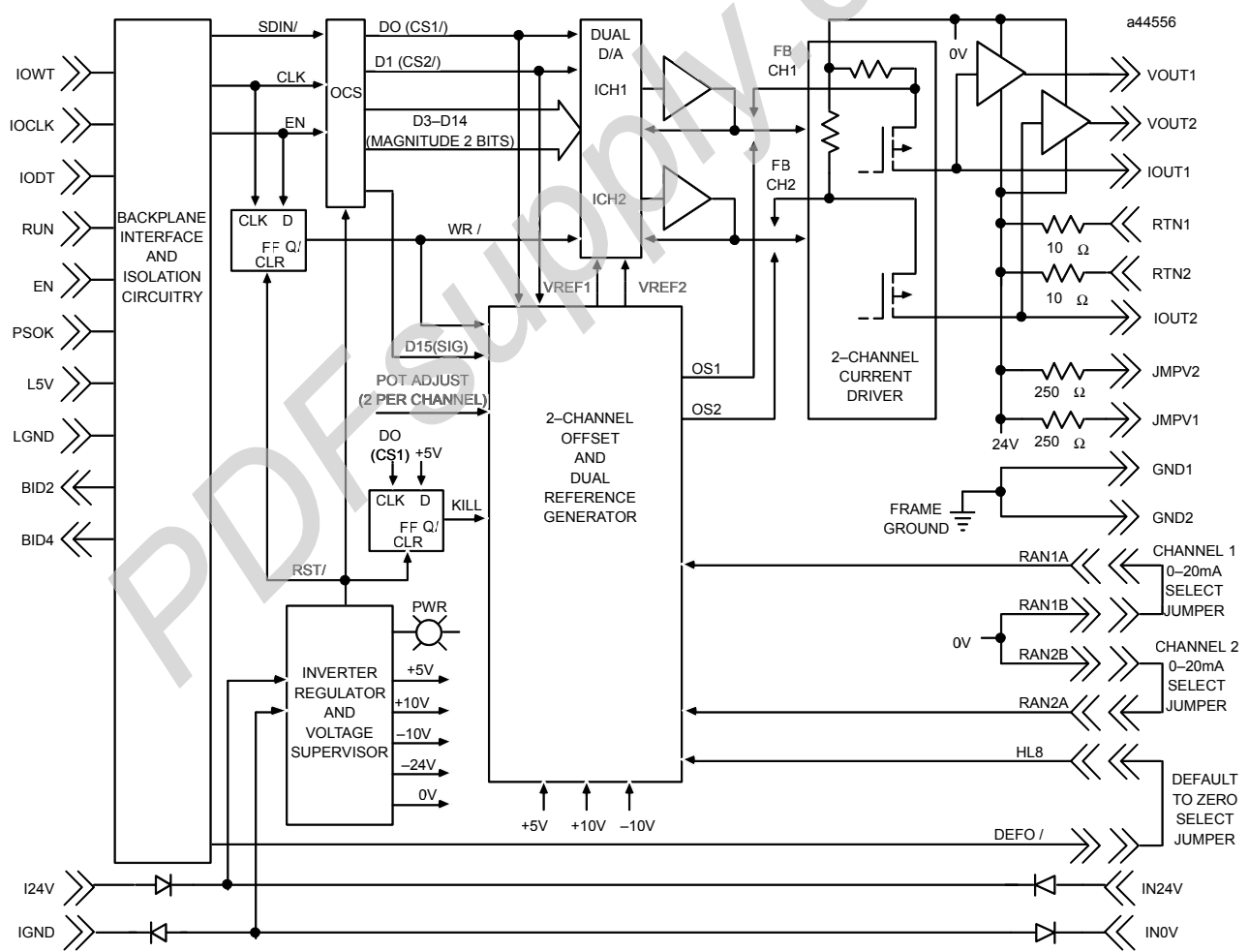
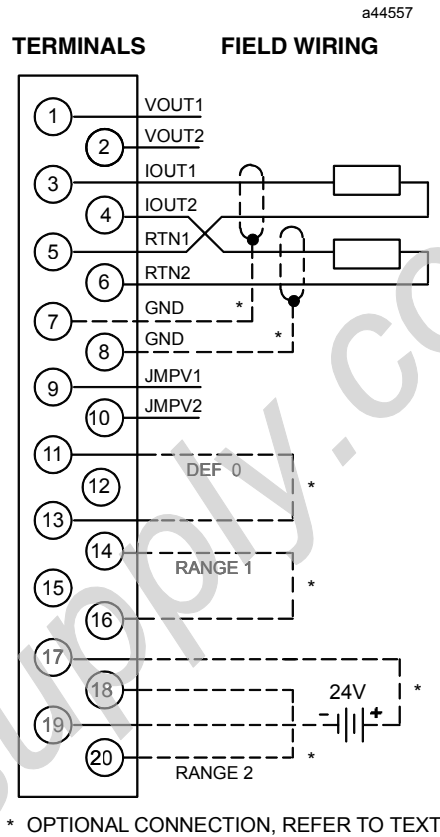

Figure 11-10. Analog Current Output Module Block Diagram - IC693ALG391

### IC693ALG391 Analog Output Module Field Wiring Diagrams

The following two figures provide information for connecting field wiring to the Analog Current Output module. Figure 3-40 shows the connections necessary for the outputs to be used as analog current outputs.



**Figure 11-11. Field Wiring - Analog Current Output Module (Current Mode) - IC693ALG391**

#### Note

An external supply can be used to power the module and the loop current.

**Please refer to Chapter 2 for wiring and shield ground connection details.**

Figure 3-41 shows the connections necessary for the outputs of the module to be used as analog voltage outputs.

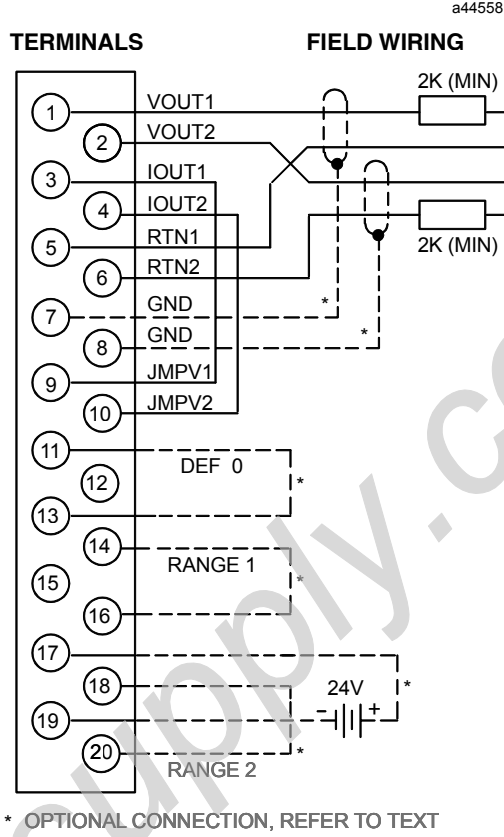

**Figure 11-12. Field Wiring - Analog Current Output Module (Voltage Mode) - IC693ALG391**

**Note**

Please refer to Chapter 2 for wiring and shield ground connection details.