

IC693BEM331

New In Stock!

GE Fanuc

<http://www.pdfsupply.com/automation/ge-fanuc/series-90-30/IC693BEM331>

Series 90-30

1-919-535-3180

**In Stock! 31 devices Genius Bus Controller I/O Link master IC693B
IC693BE IC693BEM**

www.pdfsupply.com

Email: sales@pdfsupply.com

Warnings, Cautions, and Notes as Used in this Publication

Warning

Warning notices are used in this publication to emphasize that hazardous voltages, currents, temperatures, or other conditions that could cause personal injury exist in this equipment or may be associated with its use.

In situations where inattention could cause either personal injury or damage to equipment, a Warning notice is used.

Caution

Caution notices are used where equipment might be damaged if care is not taken.

Note

Notes merely call attention to information that is especially significant to understanding and operating the equipment.

This document is based on information available at the time of its publication. While efforts have been made to be accurate, the information contained herein does not purport to cover all details or variations in hardware or software, nor to provide for every possible contingency in connection with installation, operation, or maintenance. Features may be described herein which are not present in all hardware and software systems. GE Fanuc Automation assumes no obligation of notice to holders of this document with respect to changes subsequently made.

GE Fanuc Automation makes no representation or warranty, expressed, implied, or statutory with respect to, and assumes no responsibility for the accuracy, completeness, sufficiency, or usefulness of the information contained herein. No warranties of merchantability or fitness for purpose shall apply.

The following are trademarks of GE Fanuc Automation North America, Inc.

Alam Master	Genet	PowerMotion	Series One
CIMPLICITY	Genius	ProLoop	SeriesSix
CIMPLICITY PowerTRAC	Genius PowerTRAC	PROMACRO	Series Three
CIMPLICITY 90-ADS	Helpmate	Series Five	VuMaster
CIMSTAR	Logicmaster	Series90	Workmaster
Field Control	Modelmaster		

This manual describes the features and operation of the Series 90™ -30 Genius® Bus Controller (GBC). It also provides the configuration and programming information needed to complete the interface between a Series 90-30 PLC and a Genius I/O bus.

Revisions to this Manual

Changes made to this manual, as compared to the previous version (GFK-1034A) consist of the following:

- Updated compatibility information, which includes new releases of Series 90-30 hardware and Logicmaster 90-30/20/Micro software (see page 1-7).
- A reference to the run-disable mode, which does not apply to the GBC, was deleted from page 6-14.
- Other corrections and clarifications have been made as necessary.

Content of this Manual

Chapter 1. Introduction: describes the Series 90-30 Genius Bus Controller and explains how it operates. Topics include: System Overview, I/O Devices on the Bus, Genius Bus Controller Description, Compatibility, The Genius Bus, Genius Bus Controller Operation, Datagrams, and Sending and Receiving Global Data.

Chapter 2. Operation and Timing: explains the relationship between the operation of the bus controller and global data transmission on the Genius bus. Also describes timing, and how other devices on the bus handle global data.

Chapter 3. Installation: explains how to install and remove a GBC module, connect and terminate the communications bus, remove and install the module's Terminal Assembly, and install an extra connector on the Genius bus for a Hand-held Monitor.

Chapter 4. Bus Controller Configuration: explains how to complete the Logicmaster configuration steps for a Bus Controller and its bus.

Chapter 5. Diagnostics: describes diagnostic capabilities in Series 90-30 PLC systems that use Genius I/O and communications. Topics include: Displaying and Clearing Genius Faults From The Programmer I/O Fault Table, Status Bits, and Diagnostic Messages.

Chapter 6. Communication Requests: describes the use of the COMMREQ (Communication Request) program instruction for fault handling and communications functions.

Related Publications

For more information, refer to these publications:

Genius® I/O System and Communications User's Manual (GEK-90486-1)

Genius® I/O Discrete and Analog Blocks User's Manual (GEK-90486-2)

Genius® Hand-held Monitor User's Guide (GFK-0121)

Series Six™ Bus Controller User's Manual (GFK-0171)

Series Five™ Bus Controller User's Manual (GFK-0248)

Series 90™ -30 Programmable Controller Installation Manual (GFK-0356)

Series 90™ -70 Remote I/O Scanner User's Manual (GFK-0579).

Series 90™ -70 Genius Bus Controller User's Manual (GFK-0398).

Logicmaster™ 90 Series 90-30/20/Micro Programming Software User's Manual (GFK-0466).

Series 90™ -30/20/Micro Programmable Controllers Reference Manual (GFK-0467).

Logicmaster™ 90-70 Software User's Manual (GFK-0579)

Hand-Held Programmer, Series 90™ -30 and 90-20 User's Manual (GFK-0402)

Field Control I/O Module User's Manual (GFK-0826)

Genius® Bus Interface Unit User's Manual (GFK-0825)

Series 90™ -30, 70, PLC Products, Genius™ I/O Products, Field Control™ Distributed I/O & Control Products, GE Fanuc Product Approvals, Standards, General Specifications (GFK-0867B or later)

We Welcome Your Comments and Suggestions

At GE Fanuc Automation, we strive to produce quality technical documentation. After you have used this manual, please take a few moments to complete and return the Reader's Comment Card located on the next page.

Libby Allen
Senior Technical Writer

®Genius is a registered trademark of GE Fanuc Automation North America, Inc.

Chapter 1	Introduction	1-1
	System Overview	1-1
	I/O Devices on the Bus	1-3
	Memory Required for Genius Blocks	1-3
	Memory Required for a Remote Drop	1-4
	Field Control Station	1-4
	Genius Bus Controller Description	1-5
	Status LEDs	1-5
	Module Specifications	1-6
	Compatibility	1-7
	The Genius Bus	1-8
	Genius Bus Specifications	1-8
	Selecting a Cable Type	1-8
	Genius Bus Controller Operation	1-11
	The Genius Bus Scan	1-11
	Input Data from Devices on the Bus	1-12
	Output Data from the CPU	1-12
	Diagnostics	1-13
	Datagrams	1-14
	Global Data	1-15
Chapter 2	Operation and Timing	2-1
	How the Genius Bus Controller Handles Global and Input Data	2-1
	Genius Bus Controller Receives Global or Input Data	2-2
	Genius Bus Controller Sends Output Data	2-4
	Genius Bus Controller Sends Global Data	2-5
	Global Data Without an Application Program	2-5
	Data Transmission on the Genius Bus	2-6
	Timing	2-7
	CPU Sweep Time for the Genius Bus Controller	2-7
	Bus Scan Time for Global Data	2-11
	Device-to-Device Response Time	2-11
	How Other Devices Handle Global Data Sent by the Genius Bus Controller	2-12
Chapter 3	Installation	3-1
	Choosing a Rack Location for the GBC	3-2
	Module Installation and Removal	3-4
	Module Installation	3-4
	Module Removal	3-5
	Bus Installation	3-6
	Terminal Assembly Removal and Installation	3-9
	Installing a Hand-held Monitor Connector	3-11

Contents

Chapter 4	Configuration	4-1
	Configuration Overview	4-1
	Device Types and Assigned Configuration Parameters	4-2
	Sending and Receiving Global Data	4-2
	Configuration Using Logicmaster 90 Software	4-3
	Module-specific Data	4-5
	Device-specific Data	4-6
	Entries in REF VU (Reference View Option)	4-8
	Configuration Using the Hand-held Programmer	4-9
	Hand-held Programmer Error Messages	4-9
	Select the GBC	4-10
	Configure GBC-specific Parameters	4-11
	Configure Device-specific Parameters	4-13
Chapter 5	Diagnostics	5-1
	Status Bits	5-1
	Fault Table	5-2
	Fault Table Definitions	5-4
	Technical Help	5-6
Chapter 6	Communication Requests	6-1
	COMMREQs and Passwords	6-1
	Programming for a Communication Request	6-2
	COMMREQ Command Block Format	6-3
	Command Block Contents	6-3
	Command Block Quick Reference	6-5
	The COMMREQ Instruction	6-6
	COMMREQ Inputs and Outputs	6-6
	COMMREQ Status Block	6-8
	Programming Examples	6-10
	Using COMMREQs to Send Datagrams	6-12
	COMMREQ Descriptions	6-14
	COMMREQ #8: Enable/Disable Outputs Command	6-14
	COMMREQ #13: Dequeue Datagram Command	6-15
	COMMREQ #14: Send Datagram Command	6-18
	COMMREQ #15: Request Datagram Reply Command	6-22

Chapter 1

Introduction

This chapter provides an overview of the Series 90-30 Genius Bus Controller (GBC) and its operation. The following topics are presented:

- System overview
- I/O Devices on the Bus
- Genius Bus Controller description
- Compatibility with specific equipment or software versions
- The Genius Bus
- Genius Bus Controller operation
- Datagrams
- Sending and receiving global data

System Overview

The Series 90-30 Genius Bus Controller (catalog number IC693BEM331) is used to interface a Genius I/O serial bus to a Series 90-30 PLC. The GBC receives and transmits control data of up to 128 bytes for up to 31 devices on the Genius bus.

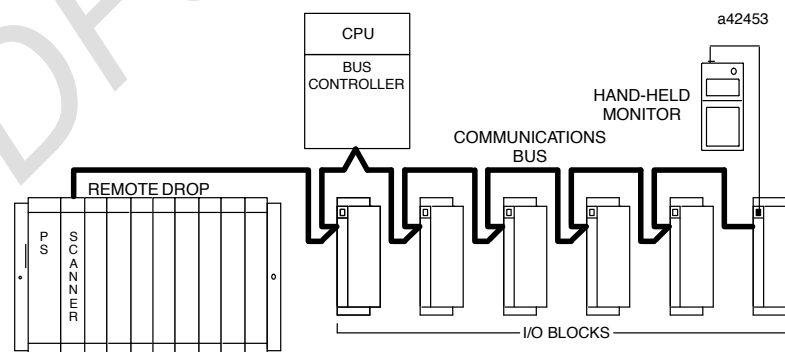

A Genius bus may serve:

- **Genius blocks**, which provide interface to a broad range of discrete, analog, and special-purpose field devices. Genius blocks are self-contained modules with advanced diagnostics capabilities and many software-configurable features.
- **Remote Drops**, Series 90-70 I/O racks that are interfaced to the bus via Remote I/O Scanner Modules. Each remote drop can include any mix of discrete and analog I/O modules, providing up to 128 bytes of input data and 128 bytes of output data.
- **Field Control I/O Station**, consisting a Bus Interface Unit (BIU) and up to eight additional Field Control modules. The BIU provides intelligent processing, I/O scanning, and feature configuration for the I/O Station.
- **Hand-held Monitor**, which can be used as a portable device or permanently-mounted. A HHM provides a convenient operator interface for block setup, data monitoring, and diagnostics.
- **Multiple hosts**, for communications using datagrams and Global Data.

A bus may feature I/O control enhanced by communications commands in the program. Or a bus may be used entirely for I/O control, with many I/O devices and no additional communications. Or, a bus may be dedicated to CPU communications, with multiple CPUs and no I/O devices. More complex systems can also be developed, with dual CPUs and one or more additional CPUs for data monitoring.

Number of Genius Bus Controllers

Up to eight GBCs or Enhanced Genius Control Modules (GCM+) can be installed in a Series 90-30 PLC system that has release 5.0 or later Logicmaster 90 software and release 5.0 or later CPU firmware. The GBC can not be installed in a system with a GCM.

I/O Devices on the Bus

The I/O devices on a bus may be Genius I/O blocks, or standard Series 90-70 I/O modules in one or more remote drops. The total number of I/O circuits that can be served by one Genius bus depends on the types of I/O devices that are used and the memory available in the CPU.

Memory Required for Genius Blocks

Memory requirements for Genius I/O blocks are shown below. For %I and %Q memory, the sizes shown are in bits. For %AI and %AQ memory, the sizes shown are in words.

Block Type	Maximum Memory Requirements			
	%I(bits)	%Q(bits)	%AI(words)	%AQ(words)
115 VAC Grouped I/O blocks	8	8		
115 VAC Isolated I/O blocks	8	8		
16 Ckt AC Input Block	16			
16 Ckt DC Sink/source blocks	16	16		
32 Ckt DC Sink/source blocks	32	32		
Relay Output blocks		16		
4 Input/2 Output Analog Blocks			4	2
Current-source Analog I/O blocks			4	2
Current-source Analog Output Blocks				6
RTD Input blocks			6	
Thermocouple blocks			6	
High-speed Counter	16	16	15	
PowerTRAC Module A	16	16	18	
PowerTRAC Module B	16	16	16	30

Many Genius I/O blocks have a configurable number of inputs or outputs, for example, the 16-circuit DC Sink/Source Block can be configured for either 16 outputs, 16 inputs, or 16 outputs with input feedback. When configuring the GBC using either Logicmaster 90 or the HHP, the number of inputs and outputs configured for the device must match what is configured in the block.

Memory Required for a Remote Drop

Together, one 90-70 Remote I/O Scanner (IC697BEM733) and the modules it serves make up a remote drop on the Genius bus.

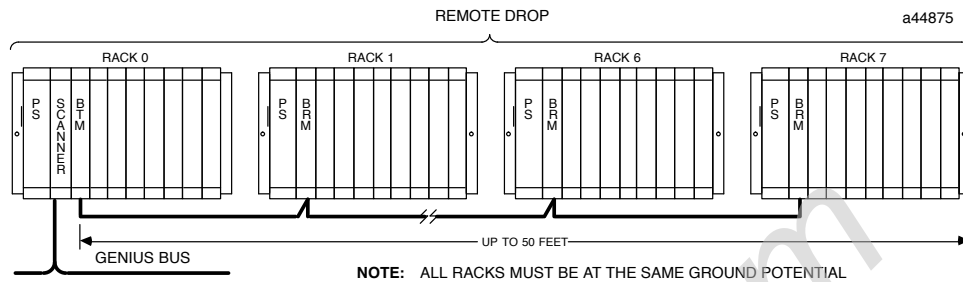

The remote drop can include any mix of Series 90-70 discrete and analog input and output modules, up to a total of 128 bytes of inputs and 128 bytes of outputs (8 discrete points represent one byte and 1 analog channel uses 2 bytes).

Field Control Station

A Field Control station, consisting of a Genius Bus Interface Unit (IC670GBI001) and the I/O modules it serves can make up a remote drop on the Genius bus.

The remote drop can include any mix of Field Control discrete and analog input and output modules, up to a total of 128 bytes of inputs and 128 bytes of outputs (8 discrete points represent one byte and 1 analog channel uses 2 bytes).

For more information, see the *Field Control™ I/O Module User's Manual* (GFK-0826) and the *Genius® Bus Interface Unit User's Manual* (GFK-0825).

Genius Bus Controller Description

The GBC is a standard, rack-mounted Series 90-30 PLC module. It plugs easily into the PLC's backplane or into a remote baseplate. The latch on the bottom of the module secures it in position. The module's Terminal Assembly, with its protective hinged cover, is removable.

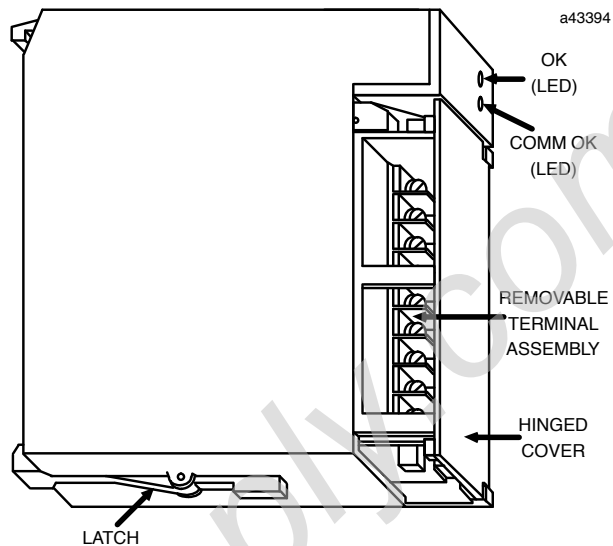

There are no DIP switches or jumpers to set on the module. Its configuration is completed using the Hand-held Programmer or the Logicmaster 90-30 software. Configuration steps are in Chapter 3.

Status LEDs

The LEDs on the front of the GBC indicate its operating status and should be on during normal operation.

- Module OK** Shows the status of the GBC. This LED turns on after power up diagnostics are completed.
- Comm OK** Shows the status of the bus. This LED is on steadily when the bus is operating properly. It blinks for intermittent bus errors and is off for a failed bus. It is also off when no configuration has been received from the PLC CPU.

Module Specifications

Ordering information	IC693BEM331
Module type†	Series 90-30 PLC module, providing Genius GlobalData communications, Genius background communications and I/O control with up to 31 other devices.
Quantity per PLC	Up to 8 GBCs in a PLC system with release 5.0 or later firmware and Logicmaster 90 software.
Current consumption	<300mA at +5VDC
Global data length per GBC	
Transmitted:	Up to 128 bytes.
Received:	Up to 128 bytes each from up to 31 other devices.
Output data length per GBC	Up to 128 bytes transmitted to each of up to 31 other devices.
Input data length per GBC	Up to 128 bytes received from each of up to 31 other devices
Series 90-30 PLC, memory types for global data	%G, %I, %Q, %AI, %AQ, %R,
LEDs	OK, COMM OK
Software diagnostics	Status bits, Fault Reporting to Series 90-30 PLC

† Refer to GFK-0867B, or later for product standards and general specifications.

Compatibility

Specific equipment or software versions required for compatibility with the GBC module are listed below.

Series 90-30 PLC The GBC can be used with the following CPU models and versions of Logicmaster 90-30 software. In each case, *later* models or versions can be used.

CPU Models IC693CPU__	CPU Firmware	Logicmaster 90 Software IC641SWP__
311S 331T 313H 323H 340B 341K	release 5.0 or later	(release 5.0 or later) 301R 306K 311A
351AA	release 6.0 or later	(release 6.0 or later) 301S 306L 311A
351AB	release 6.02 or later	(release 6.0 or later)

Series Six PLC To exchange global data with a Genius Bus Controller, the Series Six Bus Controller must be catalog number IC660CBB902F/903F (firmware version 1.5), or later.

Genius Hand-held Monitor A Genius Hand-held Monitor can be used to display the GBC bus address, its software version, and the Series Six register address configured for global data. HHM version IC660HHM501K (rev. 4.7) or later is required. There is no Hand-held Monitor connector on the GBC module, but a Hand-held Monitor can communicate with the GBC while connected to any other device on the bus. Optionally, an additional HHM mating connector (catalog number 44A736310-001-R001) can be installed on the bus near the GBC.

Series 90-30 Hand-held Programmer The GBC can be configured using a Series 90-30 Hand-held Programmer (IC693PRG300), any version. Version 1.1 (IC693PRG300D) or later of the Hand-held Programmer allows the use of %M (discrete internal) references.

Genius I/O Blocks Genius I/O blocks can be present on the same bus as the GBC. However, because the Bus Controller is *not* compatible with older phase A blocks, they should not be installed on the same bus.

The Genius Bus

Genius Bus Specifications

Bus Type	Daisy-chained bus cable; single twisted pair plus shield or Twinax. Fiber optics cable and modems can also be used.
Bus Termination	75, 100, 120, or 150 ohm resistor at both ends of electrical bus cable.
BaudRate	Configurable. 153.6 Kbaud standard, 153.6 Kbaud extended, 76.8 Kbaud, or 38.4 Kbaud.
MaximumBusLength	7500 feet at 38.4 Kbaud, 4500 feet at 76.8 Kbaud, 3500 feet at 153.6 Kbaud extended, 2000 feet at 153.6 Kbaud, standard. Maximum length at each baud rate also depends on cable type. The <i>Genius® I/O System User's Manual</i> provides a complete list of cable types, showing corresponding bus lengths and baud rates. Greater bus lengths are possible using sections of fiber optics cable with modems. (See Chapter 2 of the <i>Genius I/O System User's Manual</i> —GEK -90486-1.)
MaximumNumberof Devices	32 devices at 153.6 Kbaud standard, 153.6 Kbaud extended, or 76.8 Kbaud. 16 devices at 38.4 Kbaud. Includes GBC and typically a Hand-heldMonitor.
DataEncoding	Each bit is encoded into three dipulses, majority voted at the receiver to correct any single dipulse errors. A dipulse is an AC code consisting of a positive then negative excursion of voltage. Dipulses are individually sampled to reject low and high frequency interference.
ModulationTechnique	Frequency Shift Keying (FSK) 0 to 460.8 KHz max. (153.6 Kilobaud)
Isolationfrom Backplane	2000 volts Hi-Pot, 1500 volts transient common mode rejection.
Signal/noiseRatio	60 dB

Selecting a Cable Type

The Genius bus is a shielded twisted-pair wire that is daisy-chained from block to block and terminated at both ends. Proper cable selection is critical to successful operation of the system.

Each bus in the system can be of any cable type listed in the table below. Do not mix cables of different impedances, regardless of cable run length. The maximum run for mixed cable type equals the shortest length recommended for any of the types used. Other, small-size twisted pair shielded wire of unspecified impedance can be used for short runs of 50 feet or less, using 75 ohm terminations.

The excellent noise reduction of these cable types, and of the Genius communications system, allow the communications bus to be mixed with other signalling systems and 120 volt AC control circuits without added shielding or conduits. Conservative wiring practices, and national and local codes, require physical separation between control circuits and power distribution or motor power. Refer to sections 430 and 725 of the National Electric Code.

Cable Types

Cable # & Make	Outer Diameter	Terminating Resistor* -10% to +20% 1/2 Watt	Number of Conductors/ AWG (mm ²)	Dielectric Voltage Rating	Ambient Temp Rating	Maximum Length Cable Run, feet/meters at baud rate			
						153.6s	153.6e	76.8	38.4 ●
(A)9823 (B)9182 (C)4596 (M)M39240	.350in 8.89mm	150 ohms	2 / #22 (0.36)	30V	60C	2000ft 606m	3500ft 1061m	4500ft 1364m	7500ft 2283m
(B)89182	.322in 8.18mm	150 ohms	2 / #22 (0.36)	150V	200C	2000ft 606m	3500ft 1061m	4500ft 1364m	7500ft 2283m
(B)9841 (M)M3993	.270in 6.86mm	*120 ohms	2 / #24 (0.22)	30V	80C	1000ft 303m	1500ft 455m	2500ft 758m	3500ft 1061m
(A)9818C (B)9207 (M)M4270	.330in 8.38mm	100 ohms	2 / #20 (0.54)	300V	80C	1500ft 455m	2500ft 758m	3500ft 1061m	6000ft 1818m
(A)9109 (B)89207 (C)4798 (M)M44270	.282in 7.16mm	100 ohms	2 / #20 (0.54)	150V	200C	1500ft 455m	2500ft 758m	3500ft 1061m	6000ft 1818m
(A)9818D (B)9815	.330in 8.38mm	100 ohms	2 / #20 (0.54)			1500ft 455m	2500ft 758m	3500ft 1061m	6000ft 1818m
(A)9818 (B)9855 (M)M4230	.315in 8.00mm	100 ohms	4 (two pair) #22 (0.36)	150V	60C	1200ft 364m	1700ft 516m	3000ft 909m	4500ft 1364m
(A)9110 (B)89696 (B)89855 (M)M64230	.274in 6.96mm	100 ohms	4 (two pair) #22 (0.36)	150V	200C	1200ft 364m	1700ft 516m	3000ft 909m	4500ft 1364m
(A)9814C (B)9463 (M)M4154	.243in 6.17mm	75 ohms	2 / #20 (0.54)	150V	60C	800ft 242m	1500ft 455m	2500ft 758m	3500ft 1061m
(A)5902C (B)9302 (M)M17002	.244in 6.20mm	75 ohms	4 (two pair) #22 (0.36)	300V	80C	200ft 60m	500ft 152m	1200ft 333m	2500ft 758m

Notes: A = Alpha, B = Belden, C = Consolidated, M = Manhattan

● = Limited to 16 taps at 38.4 Kbaud

Notes

The 89182, 89207, 4794, 89696, and 89855 types are high temperature cables for use in severe environments, and are qualified for use in air plenums.

The 9815 type is water resistant, and can be used where direct burial is required.

Similar cables of equivalent terminating resistance such as 9207, 89207, and 9815 can be mixed.

Using Other Cable Types

The cable types listed in the preceding table are recommended for use. If the cable types listed above are not available, the cable selected must meet the following guidelines.

1. High quality construction. Most important is uniformity of cross section along the length of the cable. Poor quality cable may cause signal distortion, and increase the possibility of damage during installation.
2. Precision-twisted shielded wire of EIA RS-422 standard type, having a uniform number of twists per unit of length. In a catalog, this type of cable may also be listed as twinaxial cable, data cable, or computer cable.
3. Relatively high characteristic impedance; 100 to 150 ohms is best; 75 ohms is the minimum recommended.
4. Low capacitance between wires, typically less than 20pF/foot (60pF/meter). This may be accomplished by inner dielectrics of foamed type, usually polypropylene or polyethylene, having a low dielectric constant. Alternatively, the conductors may be spaced relatively far apart. Lower impedance types have smaller cross-sections, and provide easier wiring for shorter total transmission distances.
5. Shield coverage of 95% or more. Solid foil with an overlapped folded seam and drain wire is best. Braided copper is less desirable; spiral wound foil is least desirable.
6. An outer jacket that provides appropriate protection, such as water, oil, or chemical resistance. While PVC materials can be used in many installations, Teflon, polyethylene, or polypropylene are usually more durable.
7. Electrical characteristics: cable manufacturers' information about pulse rise time and NRZ data rate is useful for comparing cable types. The Genius bit consists of three AC pulses; the equivalent NRZ bit rate is about three times as great.

For assistance in selecting a specific cable type, please consult your local GE Fanuc application engineer.

Prefabricated Cables

For applications using 150 ohm cables such as Belden 9182, prefabricated cables in 15" (IC660BLC001) and 36" (IC660BLC003) lengths are available. These cables terminate in mating connectors that simplify wiring between I/O blocks.

Genius Bus Controller Operation

The GBC handles all data transfer between the PLC and the devices on its bus. In order to do this, the GBC must interface two completely separate and asynchronous activities:

- A. The Genius bus scan, a cycle of communications among the devices on a bus (including the GBC itself). The cycle follows the order of bus addresses (0-31).
- B. The CPU sweep, the cycle of actions that includes communications between the CPU and the GBC.

The GBC manages data transfer between the bus and the CPU by maintaining an on-board RAM and a serial backplane interface. The GBC places inputs in the on-board RAM when they are received from the Genius bus. When the input sweep of the PLC CPU occurs, inputs from the on-board RAM are transferred via the serial backplane to the CPU. When the output sweep of the PLC CPU occurs, outputs are received from the CPU via the serial backplane and placed in the on-board RAM. When the GBC receives the token on the Genius bus, outputs from the on-board RAM are transmitted onto the Genius bus.

The Genius Bus Scan

A bus scan consists of one complete rotation of a “token” among the devices on the bus.

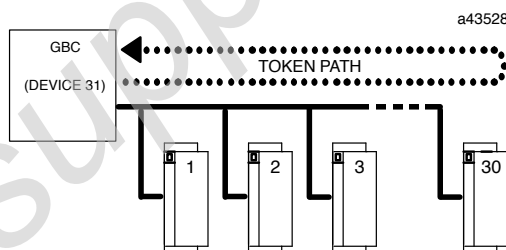

As mentioned earlier, these devices may include other GBCs, or Remote I/O Scanners, in addition to (or instead of) the Genius blocks illustrated above.

During a bus scan, the GBC automatically:

- receives all input data that has been sent by devices on the bus.
- broadcasts global data.
- updates outputs, as permitted, to the devices on the bus. Transmission of outputs from the GBC can be disabled for one or more devices on the bus.
- receives any fault messages issued by devices on the bus and issues fault reports to the CPU that can be displayed using the Logicmaster software.
- sends a single command received from the CPU (for example, a Clear Circuit Fault datagram) to the appropriate devices.

The amount of time it takes for the communications token to pass to all devices depends on the baud rate, the number and types of devices on the bus, and the use of global data and datagram communications.

Input Data from Devices on the Bus

The GBC receives input data or global data from each input block, I/O block, remote drop, or bus controller each time the block or Remote I/O Scanner has the communications token. (Because this data is broadcast, it may be received by any other bus interface module operating on the bus).

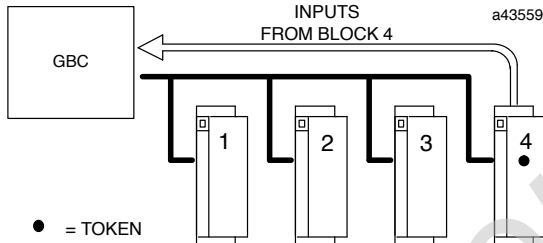

The GBC stores all the input data it receives. Once per CPU sweep, the CPU reads all discrete and analog inputs from the GBC. (Analog data is not multiplexed).

Output Data from the CPU

As the application program executes, the CPU sends outputs and any commands to the GBC. The GBC stores this data, transmitting it on the bus each time it has the communications token. Unlike inputs, which are broadcast, outputs are directed to the specific device that should receive them.

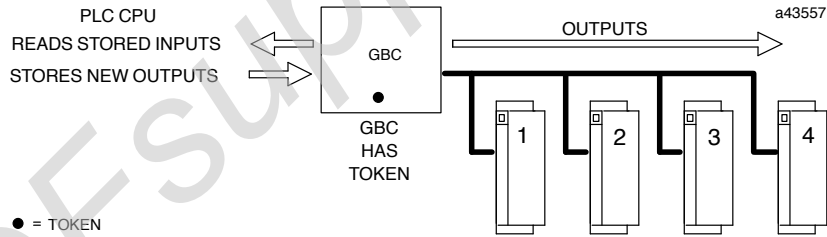

Diagnostics

Genius blocks and other devices on the bus automatically report faults, alarms and certain other predefined conditions to the PLC.

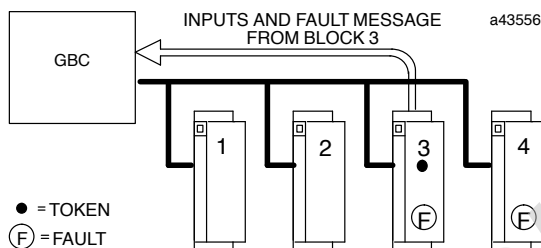

Only one diagnostic message can be sent during any bus scan. If a fault message has already been sent (by another device) during that scan, a device saves its own diagnostic message until the next available bus scan. For example, if the communications token is currently at device 3, and faults occur at devices 3 and 4 at the same time, device 3 can send its diagnostic message if another message has not already been sent. Device 4 must wait at least one more bus scan to send its diagnostic message.

The GBC stores any diagnostic messages it receives. They are read automatically by the Series 90-30 CPU. Faults can then be displayed in the fault table using the Logicmaster 90-30 software. Faults on the Genius device can be cleared using the Genius HHM. Faults in the PLC's I/O fault table and on the Genius device can be cleared from Logicmaster 90-30.

For more details about these diagnostics features, see Chapter 5.

Additional datagrams, not listed in the table on page 1-14, are sent as system messages; they do not involve any application programming. The *Genius® I/O System User's Manual* explains datagrams in detail. It also shows the formats of the data that is transferred by datagrams.

In an application program, communication request (COMMREQ) instructions are used to send datagrams and to read any unsolicited datagrams that have been received. See Chapter 6 for instructions.

Datagrams

The Series 90-30 GBC supports all Genius datagrams. Refer to Chapter 3 of the *Genius® I/O System and Communications User's Manual* (GEK-90486E-1) for further details on the use of datagrams.

Datagram Type	Description
Read ID	Requests identifying information from a device on the bus.
Read ID Reply	The automatic response to a Read ID datagram.
Read Configuration	Requests configuration data from a device on the bus.
Read Configuration Reply	The automatic response to a Read Configuration datagram.
Write Configuration	Sends configuration data to a device on the bus.
Assign Monitor	Commands a device on the bus to direct an extra copy of each Fault Report to another device on the bus.
Read Diagnostics	Requests diagnostics data from a device on the bus.
Read Diagnostics Reply	The automatic response to a Read Diagnostics datagram.
Write Point	Sends up to 1 word of bit data to a Series Six or Series Five PLC, or to a host computer.
Read Block I/O	Requests I/O data from some types of Genius blocks.
Read Block I/O Reply	The automatic response to a Read Block I/O datagram.
Report Fault	An automatic diagnostic message received from a device on the bus.
Pulse Test	Commands a discrete block to pulse its outputs.
Pulse Test Complete	Automatic indication that outputs have been pulsed.
Clear Circuit Fault	Clears one specific circuit fault.
Clear All Circuit Faults	Clears all circuit faults on bus devices.
Switch BSM	Causes a Bus Switching Module to switch to alternate bus, if operational.
Read Device	Reads up to 128 bytes of CPU data via another GBC.
Read Device Reply	The response to a Read Device datagram.
Write Device	Sends up to 128 bytes of data to a CPU, via its GBC.
Read Data	Requests temporary data from a High-speed Counter block.
Read Data Reply	The automatic reply to a Read Data datagram.
Write Data	Sends temporary data to a High-speed Counter block.
Read Map	Requests the I/O map configuration of a Remote I/O Scanner or Field Control
Read Map Reply	Automatic response to a Read Map datagram.
Write Map	Sends I/O map configuration to a Remote I/O Scanner or Field Control.

Global Data

Global Data is data that is automatically and repeatedly broadcast by a bus controller. The Series 90-30 GBC can send up to 128 bytes of Global Data and receive up to 128 bytes of Global Data each bus scan from each GCM+ or other GBC on its bus.

Sending Global Data

Once set up by configuration (see Chapter 4), Global Data is broadcast automatically. Other devices that receive the Global Data place it in these memory locations:

Series 90-30 Sends Global Data To:	Other CPU Places Global Data in this Memory Location:
Series 90-30 PLC	%I, %Q, %G, %R, %AI, %AQ, and %M (HHP configuration only). Memory type and beginning address are chosen during configuration of the <i>receiving</i> GBC.
Series 90-70 PLC	%I, %Q, %G, %R, %AI, %AQ. Memory type and beginning address are chosen during configuration of the <i>receiving</i> GBC.
Series 90-30 GCM+	%I, %Q, %G, %R, %AI, %AQ. Memory type and beginning address are chosen during configuration of the <i>receiving</i> GCM+.
Series 90-30 PLC / GCM	%G memory location corresponding to Device Number (16-23) of the Series 90-30 GBC that sent the data.
Series Six PLC	Register memory. Beginning S6 address selected during configuration of the Series 90-30 GBC that sent the data.
Series Five PLC	Register memory. Beginning S6 address selected during configuration of the Series 90-30 GBC that sent the data.
Computer	PCIM or QBIM Input Table Segment corresponding to Device Number of the Series 90-30 GBC that sent the data.

Receiving Global Data

The GBC can be configured to receive or ignore Global Data from any other GBC. The memory type and length for incoming Global Data are also selected during configuration, as described in Chapter 4.

The Series 90-30 CPU can place incoming Global Data in %I, %Q, %G, %R, %AI, %AQ, or %M (HHP configuration only) memory.

Example

In the following example, a Series 90-30 PLC (PLC 1) sends 64 bits of Global Data beginning at %I0105 to another Series 90-30 PLC (PLC 2). PLC 2 places this data into its own memory beginning at %I0017. PLC 2 sends 8 words of %AQ data beginning at %AQ0001 to PLC 1. PLC 1 places this data into its own memory beginning at %AI0032.

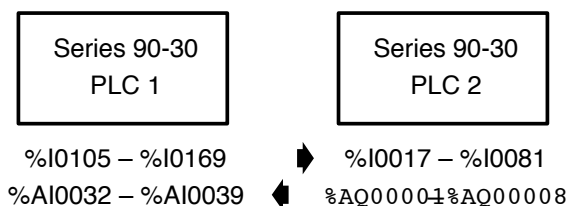

Chapter 2

Operation and Timing

This chapter explains:

- How the GBC sends and receives global and input data
- What happens to global, input, and output data if certain communications stop
- Application programming needed for global data
- The relationship between the bus scan and the CPU sweep
- How other devices handle global data received from the GBC
- How to estimate bus scan time
- How to estimate data response time
- How to avoid unnecessarily slowing down either the CPU sweep time or the scan time of the Genius bus

How the Genius Bus Controller Handles Global and Input Data

The GBC can send global data to all other global Genius devices on the bus. It can also receive and pass to the CPU global data that has been sent by other devices on the bus.

Global data can be sent from and received into %G, %Q, %AQ, %R, %I, %AI, and %M (HHP configuration only) memories in the Series 90-30 PLC. Status data uses %I memory.

Genius Bus Controller Receives Global or Input Data

The GBC passes global data and input data, from all devices for which a length has been configured, to the CPU.

In the following example, two devices, at serial bus addresses (SBAs) 18 and 22, send global data on the bus. Each module broadcasts its global data while it has the bus token. The global data is received by a GBC module (#20 in the diagram) in a Series 90-30 PLC system.

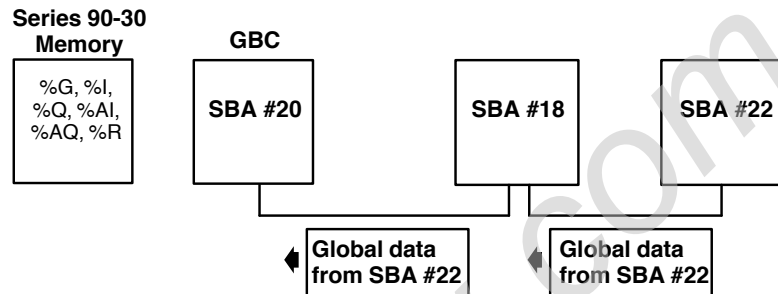

The GBC module stores the global data it receives. When the Series 90-30 CPU executes the input update portion of its sweep, it reads global data, input data, and status bits (see below) from the GBC.

In this example, the PLC CPU copies global data from the GBC into the memory locations configured for the devices at bus addresses 18 and 22.

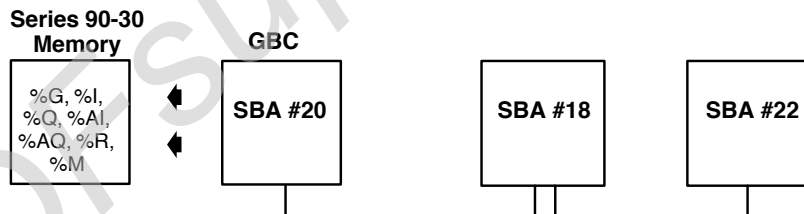

What Happens If Incoming Global or Input Data Stops

As part of the GBC configuration a **data default** (OFF or HOLD Last State) must be selected. If the GBC stops receiving data from any device(s) for which a global or input data length has been configured, the GBC sets the corresponding memory locations to the selected default. If the default is OFF, the GBC supplies 0s for the missing data. If the default is HOLD, the GBC continues to supply the last set of valid data it received from the device.

Status Bits

The GBC maintains a status bit for every potential bus device. Bit 0 of the 32 bits of status corresponds to SBA0. Bit 31 corresponds to SBA31. These bits are set to a value of 1 for every correctly configured device that is present on the bus. The bit corresponding to the module itself is always 1 if the module is working.

If the GBC does not receive, or stops receiving, communications from a device (or if the device is not configured or incorrectly configured), its bit is set to 0. In addition, the GBC defaults the data as described above. The configuration supplied to the GBC must provide a location in %I in which to place the 32 status bits. The status bits are updated every PLC sweep.

Note: The GBC can be configured to receive global data from a Series 90-30 or 90-70 PLC on the Genius bus. If this external 90-30 or 90-70 is put in STOP mode, global data is no longer sent. The GBC configured to receive this global data will default the device's data to OFF or to HOLD LAST STATE (as configured), but will not set the device's status bit to 0.

Genius Bus Controller Sends Output Data

If there is an application program running in the 90-30, it executes before the PLC CPU updates outputs. During the output portion of the sweep, if the GBC is configured to send output data to devices on the Genius bus, the PLC CPU also writes the contents of the selected memory locations to the GBC.

Example:

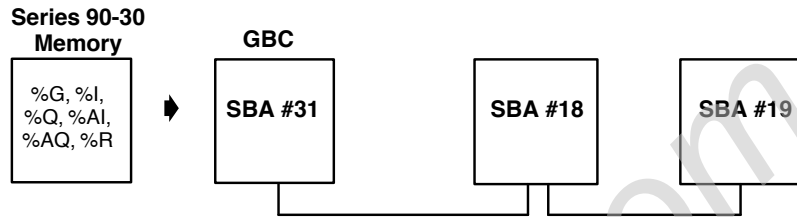

The CPU sends new output data to its GBC from the memory locations configured as outputs for devices 18 and 19. The GBC module stores the data until it receives the bus token. At that time, it directs the output data for device 18 to device 18, and then directs the output data for device 19 to device 19.

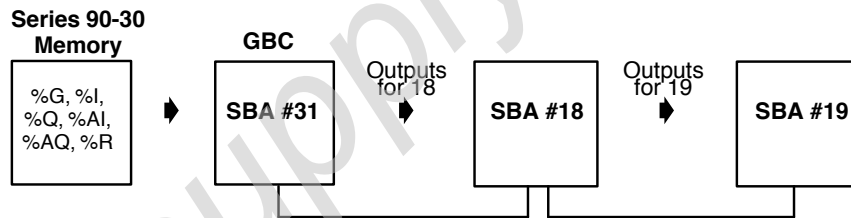

Genius Bus Controller Sends Global Data

If there is an application program running in the 90-30, it executes before the PLC CPU updates outputs. During the output portion of the sweep, if the GBC is configured to send global data to the Genius bus, the PLC CPU also writes the contents of the selected memory locations to the GBC.

In the following example, the CPU sends new global data to its GBC from the memory location configured for bus address 20.

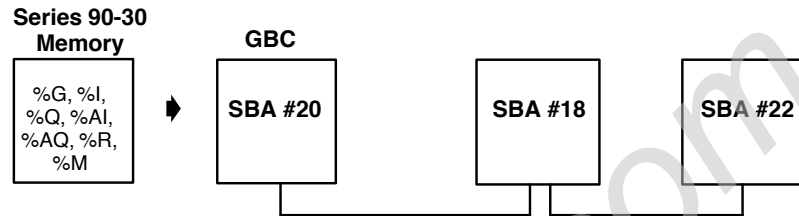

The GBC module stores this data until it receives the bus token. At that time, it broadcasts the global data to all the other devices on the bus.

In the example system, both bus addresses 18 and 22 receive the global data sent from bus address 20:

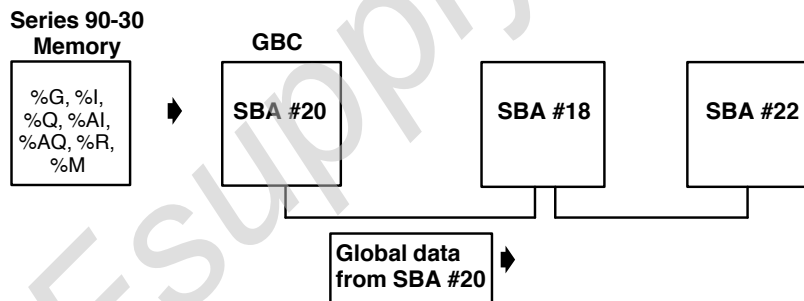

What Happens If the CPU Stops Supplying Global Data or Output Data

When the CPU stops, the GBC stops sending global data and output data.

Global Data Without an Application Program

The Series 90-30 can transmit and receive global data with or without running an application program. Configuring I/O modules in the Series 90-30 to have the same reference addresses used for global or input data allows the I/O modules to effectively exchange I/O data with another device on the bus. Thus, where it is desired to set up the Series 90-30 PLC without a program, data coming into the GBC will be mapped to %Q and %AQ (where output modules are also mapped) and outgoing global data and output data will be mapped to %I or %AI (where input modules are also mapped).

Data Transmission on the Genius Bus

Communications on the Genius bus occur by a method called “token passing”. The devices on the bus pass an implicit token, which rotates among the devices in sequence from address 0 to address 31. Unused addresses are passed with very slight delays. This sequence is called a bus scan. After device 31 has had its turn, the scan restarts at device 0.

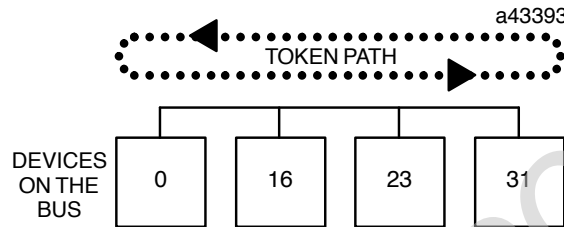

Each device on the bus can receive messages at all times (not just when it has the token). A GBC module receives all broadcast messages. These are messages that are sent to all devices on the bus. Global data and input data are types of broadcast messages.

When a device holds the token, it can send messages. To end its turn, the transmitting device sends one specific broadcast message which acts as a sign-off message, and the token passes to the next device.

If CPU sweep time is slower than bus scan time, it is possible that some incoming global data might change before it is picked up by the CPU. It is important to be sure that the data will not be sent so briefly that it will be missed.

If program execution time is faster than bus scan time, the CPU may process the same data repeatedly. Also, if output data changes too quickly, some outputs may change before they are sent out on the Genius bus. The “Timing” section in this chapter explains how to estimate bus scan time and CPU sweep time.

Timing

Global, input, and output data adds to both the CPU sweep time in the Series 90-30 and to the scan time of the Genius bus. You can estimate the CPU sweep time and bus scan time added by data transmissions, and the time it can take for a Series 90-30 PLC to send data and then receive a response based on that data.

CPU Sweep Time for the Genius Bus Controller

The impact of global, input, and output data on CPU sweep time depends on the type of PLC, the GBC rack location, and the types and amounts of data transferred. Refer to the following table.

CPU Model	Rack Location	Base Contribution (milliseconds)	Per Byte Contribution (microseconds/byte)
311/313	N/A	0.887	13
331	main	0.967	21
	expansion	1.164	29
	remote	1.920	76
340/341	main	0.666	17
	expansion	0.901	24
	remote	1.626	72

1. Once configured, the GBC always provides 32 status bits to the CPU, adding to the CPU sweep time. The time required for this is listed in the table above as the “base time” under “Status Bits + Incoming Global/Input Data”.

For example, if a GBC is installed in a local or expansion rack of a model 331 PLC, the base time for status bits and incoming global data is 1.2ms.

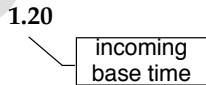

Because the GBC always supplies its status bits to the CPU, the incoming data base time must be included in the sweep time calculation, regardless of whether or not the GBC passes incoming global/input data to the CPU. A sweep time example illustrating this is on the next page.

2. If the GBC passes incoming global/input data from one or more bus devices to the CPU, multiply the total of: the number of global data bytes passed to the CPU by the corresponding “per byte” time in microseconds as listed in the table. For the model 331 PLC CPU only, incoming bit data has a slightly greater per byte rate than word data. For destination tables %G, %I, and %Q, use the *bit* per-byte time. For %R, %AI, or %AQ, use the *word* per-byte rate.

In the same example, if the GBC passes 16 bytes of global/input data each from 6 other devices to the model 331 CPU's %R, %AI, or %AQ memory, the base time plus the time required to transfer the data is:

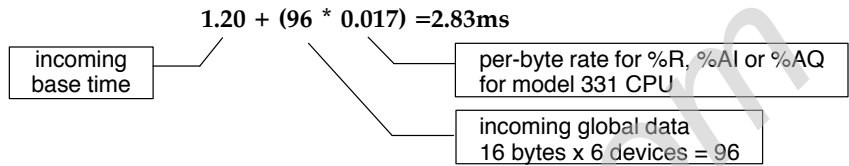

3. If the GBC will also send global/output data, find the additional base time for outgoing global data. Add bytes of output data for each output device. To this base time, add: the number of bytes sent multiplied by a per-byte time in microseconds as shown in the table. Again, for the model 331, use the “bit” per-byte time for destination tables %G, %I, and %Q or the “word” per-byte rate for %R, %AI, or %AQ.

If the same GBC sends 64 bytes of global data, the CPU sweep time impact of sending the data is:

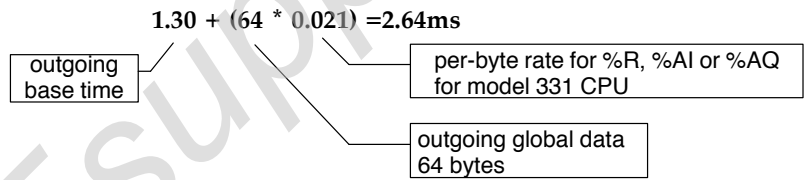

If the GBC does not send global data or output data, no base time or per-byte time is included in the CPU sweep. This is different from the incoming global data calculation, where incoming base time is always included.

4. The total sweep time impact for a GBC is the sum of its read and write times.

For the same example:

$$2.83 + 2.64 = 5.47\text{ms}$$

Example with Genius Bus Controller in a Remote Rack

If the same GBC was installed in a remote rack, exchanging the same amounts of data with the CPU would take considerably longer. The complete calculation is:

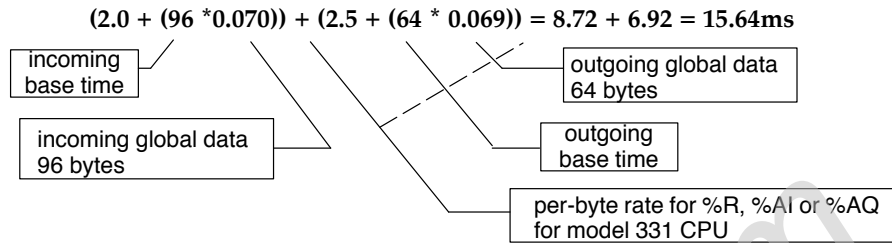

Example with No Incoming Global Data or Input Data

If a GBC sends global data but does not pass any incoming global data to the CPU, the time required to transfer its status bits still impacts the CPU sweep. *The base time for incoming data described in step 1 must always be included in the sweep time calculation.*

For example, a GBC in an expansion rack passes no incoming global data to the CPU, but sends 48 bytes each bus scan. The sweep time impact is:

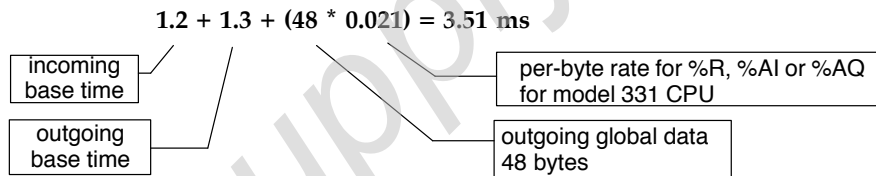

Example with No Outgoing Global/Output Data, Genius Bus Controller Receives both Bit and Word Data

If the GBC passes incoming global data to the CPU but does not send any, the sweep time calculation includes only the incoming data base time and per-byte time. Again, if the PLC CPU is a model 331, incoming data sent to %G, %I, or %Q has a slightly greater per-byte rate than data sent to %R, %AI, or %AQ, so the two data types are separated in the calculation.

In this example, a GBC in a local rack of a model 331 passes 32 words and 256 bits of incoming global data to its CPU. It does not send any global data. The sweep time impact is:

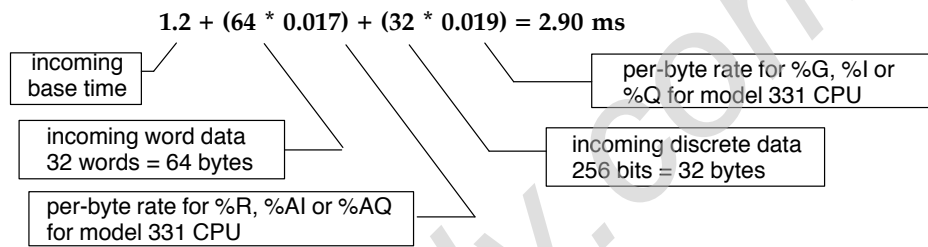

Reducing the Sweep Time Impact

To minimize the impact of global data transfer on the CPU sweep time, you can:

- Install GBC modules in the main rack or an expansion rack, not in a remote rack.
- Eliminate unwanted incoming global data. If there is global data being transferred on the bus that the Series 90-30 does not need, do not configure to receive it.

Timing is not affected by the number or type of memory assignments made for incoming global data.

Bus Scan Time for Global Data

The minimum amount of time required for the token to make a complete bus rotation is 3mS. This minimum time limit is imposed by the GBC and other types of bus interface modules. The maximum bus scan time is 400mS, but this will not be reached under normal circumstances.

The presence of other PLCs, a host computer, I/O blocks, or datagrams on the bus adds to the bus scan time (although the time required for each individual message transmission remains the same). Using one of the slower baud rates also increases bus scan time. The scan time increase from 153.6 Kbaud standard to 153.6 Kbaud extended is slight. But scan time is about twice as long at 76.8 Kbaud and four times as long at 38.4 Kbaud.

Estimating Bus Scan Time

Refer to "Timing Considerations" in the *Genius® I/O System and Communications User's Manual* (GEK-90486-1) for instructions on how to estimate bus scan time.

You will need to add up the time needed to service all devices on the bus, including the GBC, at the bus baud rate. All 32 possible bus addresses (including unused bus addresses) must be accounted for. See the table below.

Device Type	Contribution time in mS at each baud rate			
	153.6 Kb std	153.6 Kb ext	76.8 Kb	38.4 Kb
GBC	0.586	0.658	1.324	2.655
Unused Bus Address	0.026	0.052	0.104	0.208

Reducing Bus Scan Time

Bus scan time can be shortened by reducing the number of devices on the bus, reducing the amount of global data transmitted, or both.

Device-to-Device Response Time

If you want to find out approximately how long it will take for one module to send global data to another and to receive a response based upon that data, add together the maximum times that may be required for each portion of the input to output cycle. Refer to "Timing Considerations" in the *Genius® I/O System and Communications User's Manual* (GEK-90486-1) for more information.

How Other Devices Handle Global Data Sent by the Genius Bus Controller

Global data sent by a GBC can be received by any other Bus Controller, Genius Communications Module (GCM), Personal Computer Interface Module (PCIM), or Q-Bus Interface Module (QBIM) on the bus. All devices receive the same global data message from the GBC. How each type of device handles the message is summarized below. (See the table on page 1-15 for a list of memory locations for each module type.)

Series 90-30 PLC GBC Module	A GBC in another Series 90-30 PLC places the data in the memory location specified when that GBC is configured.
Series 90-30 PLC GCM+ Module	A GCM+ on another Series 90-30 PLC places the data in the memory location specified when that GCM+ is configured. If the GCM+ does not need all the data, a message offset and length can be specified.
Series 90-30 PLC GCM Module	The Series 90-30 Genius Communications Module uses specific %G memory locations for global data. It places incoming global data in the %G memory location corresponding to the Device Number (16–23) of the Series 90-30 GBC that sent the data. The GCM will not receive global data sent from SBAs 0–15 or 24–31.
Series 90-30 PLC	The Series 90-30 PLC places incoming global data into the memory location selected during configuration of its GBC.
Series 90-70 PLC	The Series 90-70 PLC places incoming global data into the memory location selected during configuration of its GBC.
Series Six PLC	If a Series Six Reference is specified during GBC configuration, any Series Six and / or Series Five PLC on the bus will automatically receive all global data from the GBC and place it in that register location.
Series Five PLC	See Series Six PLC.
Computer	Data from the GBC is placed into the PCIM or QBIM Input Table Segment corresponding to the bus address of the GBC. The computer's application program is responsible for transferring global data between the CPU and the PCIM or QBIM.
I/O Blocks	I/O blocks (controlled by another host) can be present on the bus, but cannot receive global data.

Chapter 3

Installation

This chapter explains how to:

- determine the maximum number of GBCs and Genius blocks that can be configured for your system
- install and remove a GBC module
- connect and terminate the communications bus
- remove and install the module's Terminal Assembly
- install an extra connector on the Genius bus for a Hand-held Monitor

Note

If the Genius bus is operating at 76.8Kbaud, the bus must be properly terminated before powering-up the GBC module.

The module will not power up on an unterminated bus at 76.8Kbaud.

The GBC operates only on a correctly terminated Genius bus. If you want to test it without any bus connections, place a 75-ohm resistor across the Serial 1 and Serial 2 terminals to ensure that the module will power-up.

Choosing a Rack Location for the GBC

The GBC module can be located in any I/O slot in Series 90-30 CPU expansion and remote baseplates, or I/O racks, including remote racks. For the most efficient system operation, the main baseplate is preferred. See the "Timing" section of Chapter 2 for details.

A maximum of eight GBC modules can be used in the same Series 90-30 PLC. However, depending on the number of I/O devices configured on the GBCs and the number of other I/O modules in your system, your system may not be able to handle all eight GBCs.

Note: Up to four references can be configured for each SBA on a GBC bus.

To estimate whether the system you want to design is possible, follow steps 1–3, below.

1. The I/O configuration block uses a base of 90 bytes of user memory. Each smart module uses 257 bytes of user memory for parameter data. Finally, every I/O segment uses an additional 40 bytes of user memory.

Example of segments:

A GBC with SBA 0 I1 and SBA 2 Q2 configured has **three** I/O segments: the status in %I, and the two configured under the SBAs).

A discrete input module has **one** segment (%I).

2. The total user memory required by a configuration is the sum of all these parts:

$$\begin{array}{l} \text{base configuration size (90)} \\ \text{number of smart modules *257} \\ \hline \text{+number of segments *40} \\ \hline \text{total user memory required for the configuration} \end{array}$$

3. The total user memory available for configuration varies with CPU model. If the number derived from the formula above is greater than the number next to the CPU that you are using, the system will not work due to memory limitations.

CPU	Available Memory (bytes)
311	4,720
313	4,720
323	4,720
331	4,656
340/341	8,176
351	16,368

Example:

A user wants to configure three GBCs (the first with 53 segments, the second with 26 segments, and the third with 11 segments), 1 discrete input module, 1 analog input module, 1 discrete output module, and 1 discrete combo input/output module.

First, add up the number of segments:

- First GBC: 1 for status + 53 configured segments
- Second GBC: 1 for status + 26 configured segments
- Third GBC: 1 for status + 11 configured segments
- Discrete input module: 1 (%I)
- Analog input module 1 (%AI)
- Discrete output module: 1 (%Q)
- Discrete I/O module: 1 for input (%I) + 1 for output (%Q)

for a total of 98 segments.

Now, add them all up:

$$\begin{array}{r} 90 = \quad 90 \\ 3 \times 257 = 771 \\ \underline{98 \times 40 = 3,920} \\ 4,781 \end{array}$$

This will fit in a 341 CPU, but not in a 331 CPU.

Module Installation and Removal

Module Installation

The GBC module is installed and removed in the same manner as all other Series 90-30 modules. **Power must be OFF when installing or removing the module.**

To install the GBC in the Series 90-30 PLC baseplate:

1. Grasp the module with the terminal board toward you and the rear hook facing away from you.
2. Align the module with the desired base slot and connector. Tilt the module upward so that the top rear hook on the module engages the slot on the baseplate.
3. Swing the module downward until the connectors mate and the locking lever on the bottom of the module snaps into place, engaging the baseplate notch.

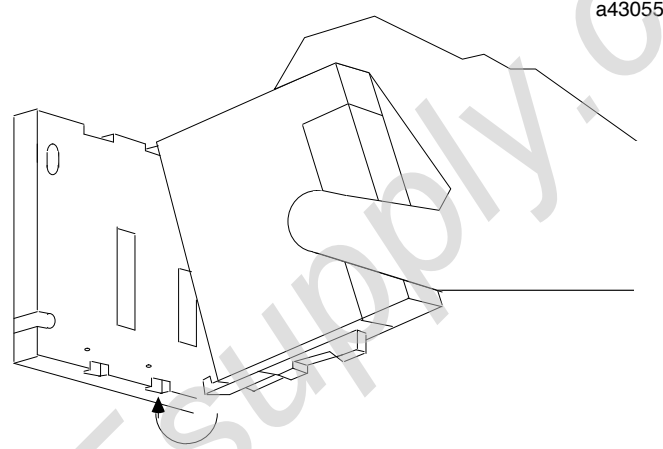

Module Removal

The module can be removed without powering down the communications bus, provided the incoming and outgoing Serial 1 wires have been connected to one terminal and the Serial 2 wires have been connected to one terminal or jumpered as described on the next page. If this has been done, do not disconnect the bus cable or any terminating resistor. Before removing the GBC, carefully remove the Terminal Assembly from the front of the GBC (see page 3-9). Avoid contact with exposed cable wiring. Place the Terminal Assembly, with the bus wiring still attached, in a protected location.

Caution

If exposed wiring comes in contact with conductive material, data on the bus may be corrupted, possibly causing the system to shut down.

If the rest of the bus is powered down, the bus wiring can be removed from the module.

To remove the module:

1. Locate the release lever on the bottom of the module. Firmly press it up toward the module.
2. While holding the module firmly at the top, continue fully depressing the release lever and swing the module upward.
3. Disengage the hook at the top of the module by raising the module up and moving it away from the baseplate.

a43056

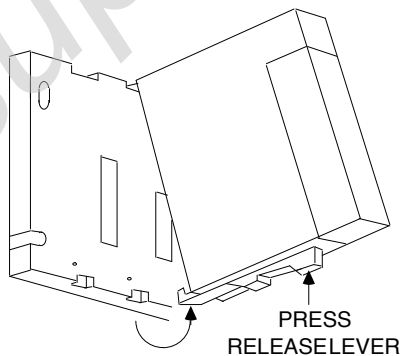

Bus Installation

The Genius bus is connected to the terminal assembly on the front of the GBC module. For the GBC module, these terminals have the following assignments:

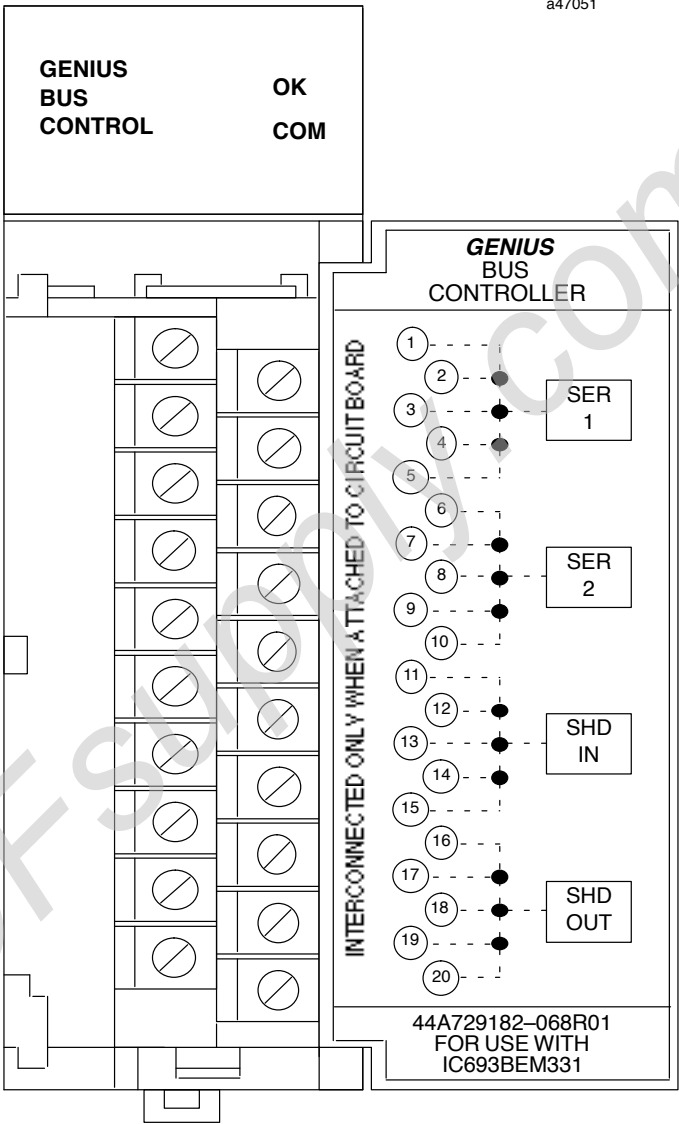

Connection can be made to any of the terminals in a group. The cable is routed to and from the terminals via the bottom of the Terminal Assembly cavity.

Using the cable type selected for the application, connect the devices as shown in the following figure. Each terminal accepts up to one AWG #14 (2.10mm²) wire or two AWG #16 (1.32mm²) wires using ring or lug-type connectors.

Caution

The bus shield wires are not insulated; do not permit them to touch other wires or terminals. Spaghetti tubing should be used to cover these wires.

4. Connect Serial 1 terminals of adjacent devices and the Serial 2 terminals of adjacent devices.
5. Connect Shield In to the Shield Out terminal of the previous device. (For the first device on the bus, Shield In is not connected.)
6. Connect Shield Out to the Shield In terminal of the next device. (For the last device on the bus, Shield Out is not connected.)

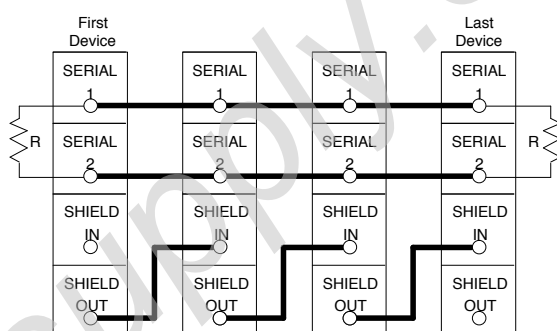

Serial Wire Connections

The Serial 1 and Serial 2 terminals are interconnected *on the circuit board*, not on the terminal strip. Incoming and outgoing signal wire pairs can be connected to either one or two Serial 1 or Serial 2 terminals:

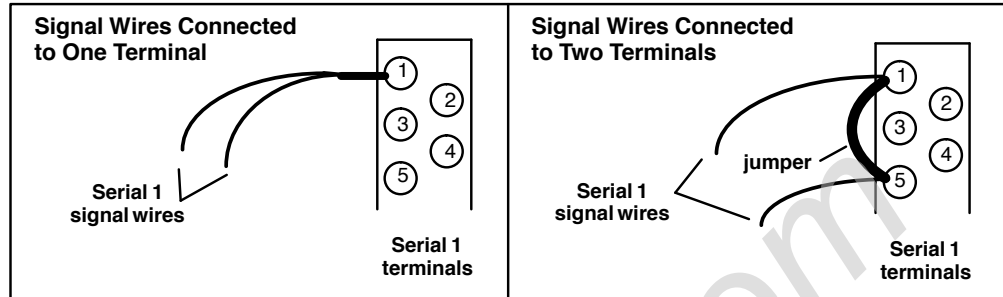

If you are connecting two signal wires to the same terminal, use spade or lug-type connectors, or twist the exposed ends of the wires together before inserting them. This will allow future removal of the Terminal Assembly without disrupting other devices on the bus (see "Module Removal", in this chapter).

If you are connecting two signal wires to separate terminals, install a jumper between the two terminals as shown on the right above. Failure to install the jumper will cause the entire bus to be disrupted whenever the faceplate is removed.

Terminating the Bus

The bus must be terminated at both ends by its characteristic impedance. The list of suitable cable types in the *Genius I/O System and Communications User's Manual* includes the termination requirements for each cable type. If the GBC is at the end of the bus, install a resistor of the appropriate impedance across its Serial 1 and Serial 2 terminals as shown below.

If you need to install the terminating resistor across terminals different than those used for the signal wires, attach jumper wires between the signal wire terminals and the resistor terminals to prevent the bus from becoming unterminated if the Terminal Assembly is removed. Failure to do so will cause the entire bus to be disrupted whenever the faceplate is removed.

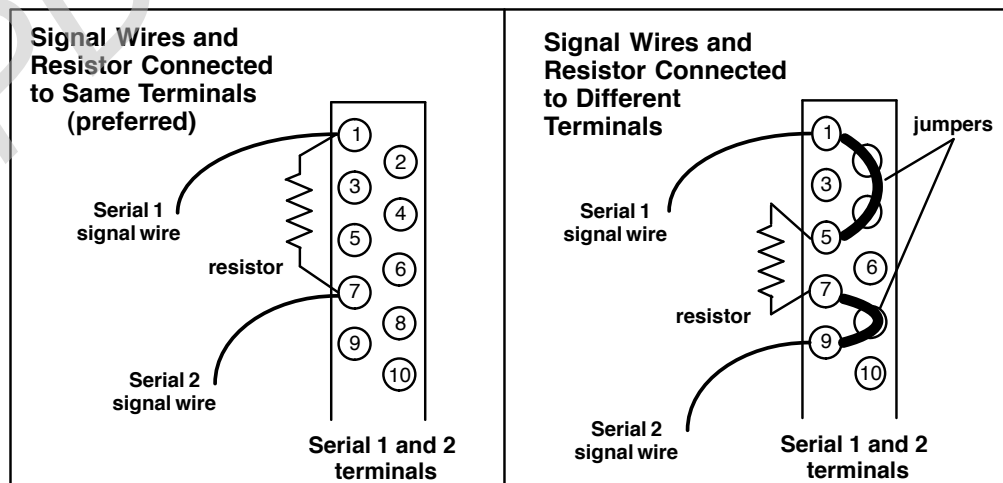

Terminal Assembly Removal and Installation

The Terminal Assembly of all Series 90-30 modules can be removed or installed from the module as described below.

Terminal Assembly Removal

1. Open the hinged cover on the front of the module.
2. There is a jacking lever above the wiring terminals, on the left. Push this lever upward to release the terminal block.

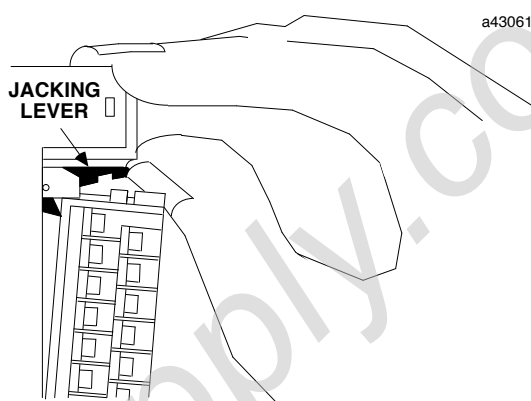

3. Grasp the narrower pull-tab located at the right of the retaining tab. Pull the tab toward you until the contacts have separated from the module housing and the hook has disengaged.

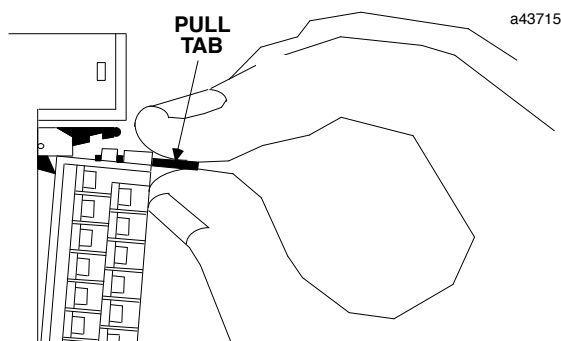

Terminal Assembly Installation

To replace the Terminal Assembly, follow the steps below. If wiring is already in place, be sure that the Terminal Assembly is being connected to the proper type of module.

Caution

Check the label on the hinged door and the label on the module to be sure they match. If a wired Terminal Assembly is installed on the wrong module type, damage to the module may result.

1. If the pull tab at the top of the Terminal Assembly is extended, push it back. Close the Terminal Assembly door.
2. Place the hook at the bottom of the Terminal Assembly into the corresponding slot at the bottom of the module.
3. Pivot the Terminal Assembly upward and firmly press it into position.
4. Open the door and check to be sure that the latch is securely holding the Terminal Assembly in place.

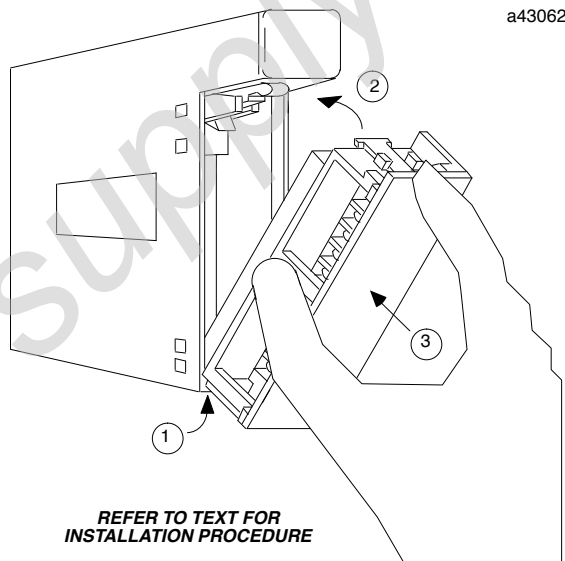

Installing a Hand-held Monitor Connector

The GBC does not have a built-in connector for a Genius Hand-held Monitor. However, a Hand-held Monitor connector can be added directly to the serial bus at any location.

The unit shown below (catalog number 44A736310-001-R001) provides a Hand-held Monitor connector and serial bus terminals in a single convenient package.

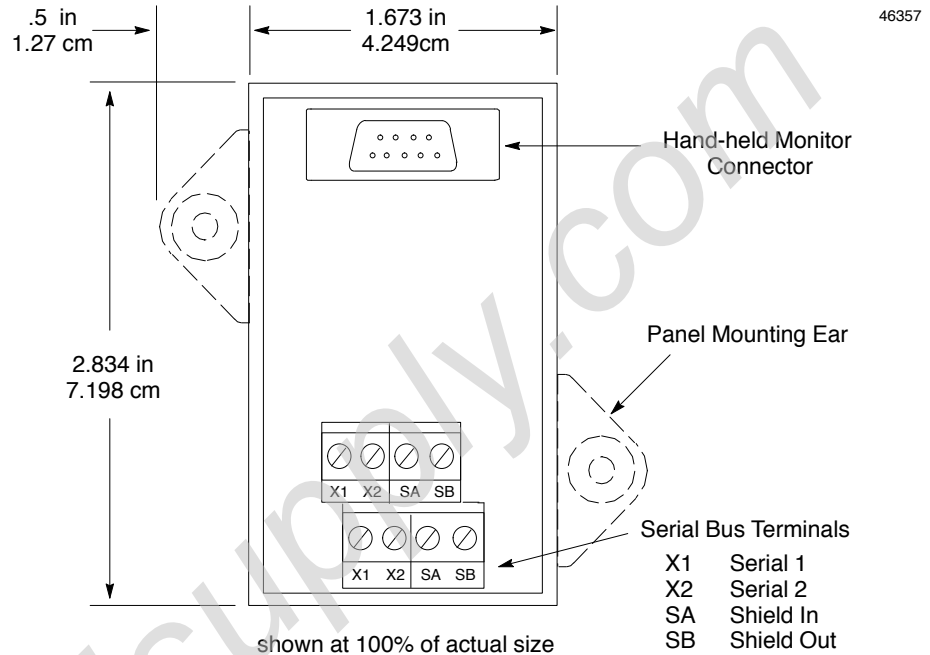

Mounting the HHM Connector

This unit can be easily mounted on a rail such as a standard 35mm or 15mm DIN rail. The panel-mounting ears are not used if the unit is installed on a DIN rail.

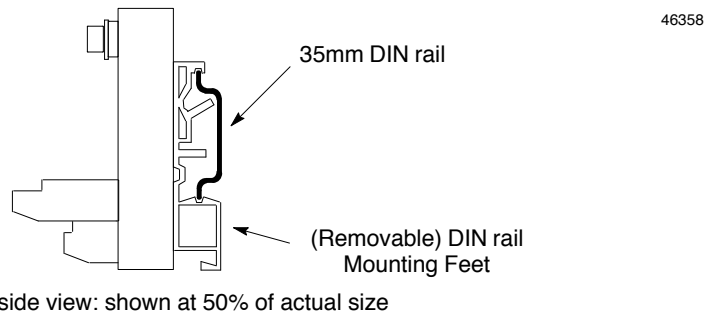

Alternatively, it can be installed directly on a panel using screws through its mounting ears. The DIN rail feet on the back of the unit are removed when the unit is panel-mounted.

Making the Bus Connections

The Hand-held Monitor connector has two sets of terminals; one for incoming cable and the other for outgoing cable.

Connect the Serial 1, Serial 2, and Shield In terminal of either connector to the previous device. Connect the Serial 1, Serial 2, and Shield In terminal of the other connector to the next device.

The following illustration shows connections for incoming and outgoing serial bus cable. As with other devices, the HHM connector can be at either end of its bus. If it is, there will only be one bus cable attached.

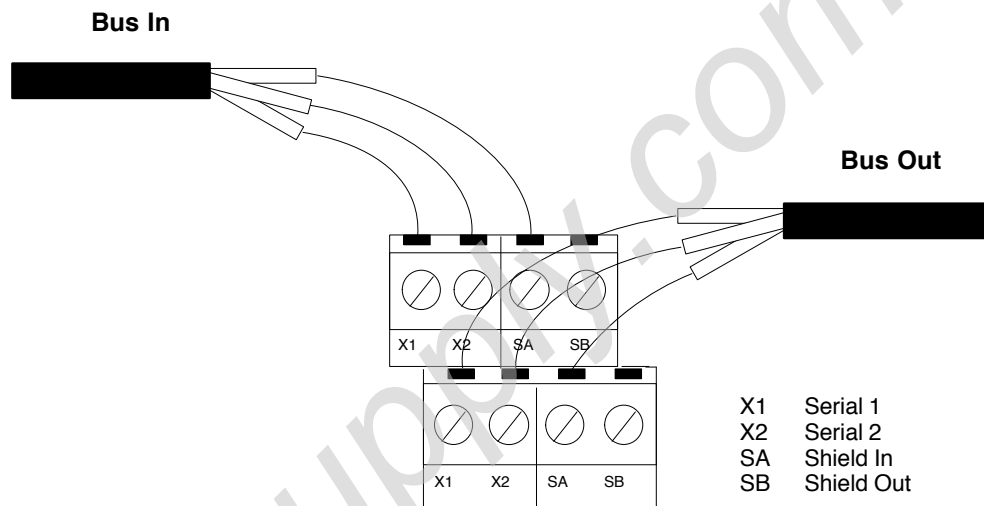

As with other devices, if the Hand-held Monitor Connector is at either end of its bus, install an appropriate terminating resistor across the Serial 1 and Serial 2 terminals. The *Genius I/O System and Communications User's Manual* (GEK-90486-1) lists appropriate terminating resistors for each recommended bus cable type.

Installing the Hand-held Monitor D-Shell Connector on the Bus

You have the option of installing the D-shell connector that is supplied with the Hand-held Monitor, if you do not wish to use the connector described on page 3-11. You will need a mounting plate (IC660MPH509) for this type of installation.

1. Using the mounting plate as a template, cut an opening in the panel for the mating connector. Also drill two holes for the mounting hardware.
2. Attach the mounting plate and mating connector to the panel using the mounting hardware supplied.
3. Secure the two ends* of the serial bus cable to the back of the panel using strain relief brackets.
4. Strip the ends of the wires. Twist the two Serial 1 wires together and attach them to pin 5 of the connector. Twist the Serial 2 wires together and attach them to pin 9. Similarly, attach the Shield wire(s)* to pin 4.

The following illustration shows connections for incoming and outgoing serial bus cable. As with other devices, the HHM connector may be at either end of its bus. If it is, there will only be one bus cable attached.

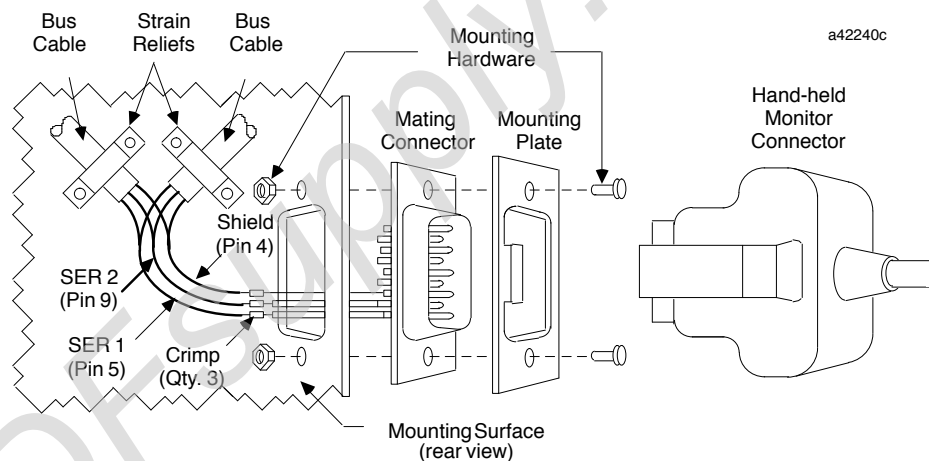

When making bus connections, the maximum exposed length of bare wires should be two inches. For added protection, each shield drain wire should be insulated with spaghetti tubing to prevent the Shield In and Shield Out wires from touching each other.

If the Hand-held Monitor connector is at either end of its bus, it is necessary to install an appropriate terminating resistor across the Serial 1 and Serial 2 wires. The *Genius I/O System and Communications User's Manual* lists appropriate terminating resistors for each recommended bus cable type.

Chapter 4

Configuration

This chapter describes configuration procedures for the GBC. Topics include:

- Configuration overview
- Configuration using the Logicmaster 90 software
- Configuration using the Hand-held Programmer

Configuration Overview

A GBC module can support up to 31 devices on its bus. Each device has an SBA and a device type associated with it. The GBC and the devices on its bus must be configured in two basic, different procedures.

1. The GBC must be configured as part of the Series 90-30 PLC system using the Logicmaster 90-30 software (release 5 or later) or a Hand-held Programmer (HHP). This includes:
 - A. parameters for the GBC module itself, and
 - B. parameters specific to the devices on the GBC's bus.
2. The devices on the bus must be configured separately. This includes:
 - A. I/O blocks with an HHM and/or Write Configuration COMMREQs, and
 - B. remote drops using Logicmaster 90-70.

Eight-point devices can not be configured in word memories.

For additional information on the configuration of devices and remote drops, see:

Genius® I/O System and Communications User's Manual (GEK-90486-1) – Explains how Global Data works. Details the data that can be transferred using Read Configuration and Write Configuration COMMREQs.

Genius® Discrete and Analog Blocks User's Manual (GEK-90486-2) – includes instructions for configuring most I/O blocks.

Logicmaster 90-70 Software User's Manual (GFK-0579) – covers configuration of the entire PLC.

GFK-0402: Hand-Held Programmer, Series 90™ -30 and 90-20 Programmable Controllers User's Manual – Describes the Hand-held Programmer displays, and explains operator procedures for module configuration, programming, and data monitoring.

Device Types and Assigned Configuration Parameters

Device Type	Input1 Ref/Length	Input2 Ref/Length	Output1 Ref/Length	Output2 Ref/Length
GENERIC*	User Input (up to 128 bytes)	User Input (up to 128 bytes)	User Input (up to 128 bytes)	User Input (up to 128 bytes)
8%I	8%I	0	0	0
16%I	16%I	0	0	0
32%I	32%I	0	0	0
8%Q	0	0	8%Q	0
16%Q	0	0	16%Q	0
32%Q	0	0	32%Q	0
8%IQ	8%IQ	0	8%IQ	0
16%IQ	16%IQ	0	16%IQ	0
32%IQ	32%IQ	0	32%IQ	0
6%AI	6%AI	0	0	0
6%AQ	0	0	6%AQ	0
4%A/12%Q	4%AI	0	2%AQ	0
HSC	15%AI	16%I	16%Q	0
PWRTRACA	16%I	18%AI	16%Q	0
PWRTRACB	16% I	30%AI	16%Q	0
CONTROL (this GBC)	0	0	User Input (up to 128 bytes)	User Input (up to 128 bytes)

* Note: When configuring GENERIC devices with mixed data types, discrete data must be assigned to Input1 and Output1 locations. Analog data must be assigned to Input2 and Output2 locations.

Sending and Receiving Global Data

To transmit global data, a device must be configured as CONTROL. (Only the SBA of the GBC module itself can be configured as CONTROL.) Set up the output lengths to transmit global data. Up to 128 bytes can be configured for the total of Output1 and Output2 Lengths. Discrete(%Q) data will automatically be adjusted to multiples of 8 for byte alignment.

For a device to receive global data, configure it as GENERIC and specify memory types and lengths for the incoming data. Up to 128 bytes can be configured for the total of Input1 and Input2 Lengths. Discrete(%I) data will automatically be adjusted to multiples of 8 for byte alignment.

For a complete description of Global Data and how it works, refer to Chapter 7 of *Genius® I/O System and Communications User's Manual* (GEK-90486-1).

Configuration Using Logicmaster 90 Software

With the GBC installed in its proper rack/slot location, the Logicmaster 90-30 configurator software program (release 5 or later) can be used to configure the module in the offline mode. Once the complete set of configuration data has been entered, it must then be downloaded to the PLC (in the online mode) to become effective in the GBC Module.

The GBC is configured by completing setup screens in the configurator software. The setup screens that are used for this module are shown and described below.

In the I/O configuration screen, place the cursor at the slot representation corresponding to the GBC's installed location in the PLC rack.

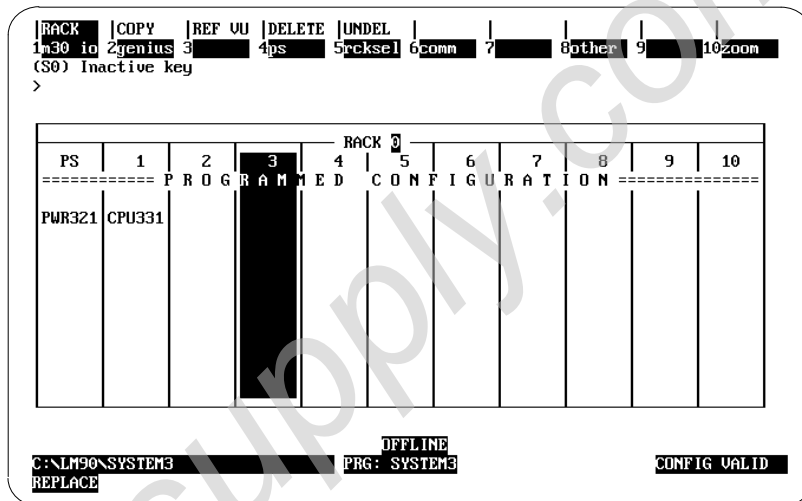

Select F2 (genius). The following screen will appear.

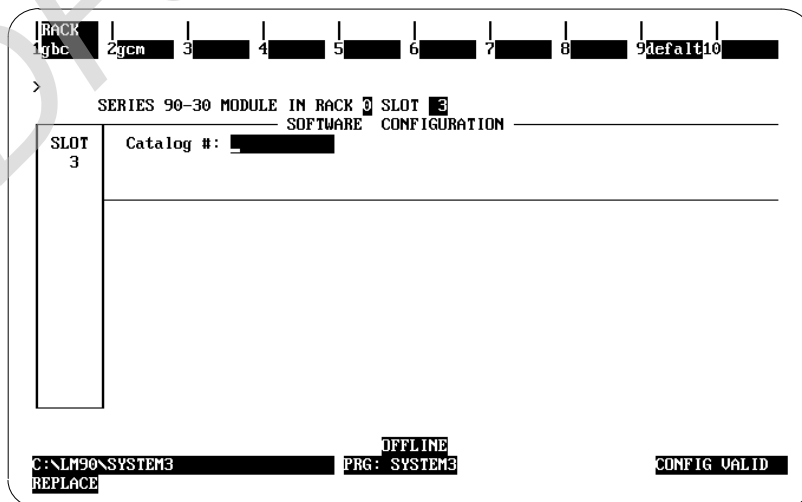

Press **F1** (gbc) and then the **Enter** key to select the GBC. The following screen will appear. (Note that the **default** softkey, **F9**, is inactive for the GBC module.)

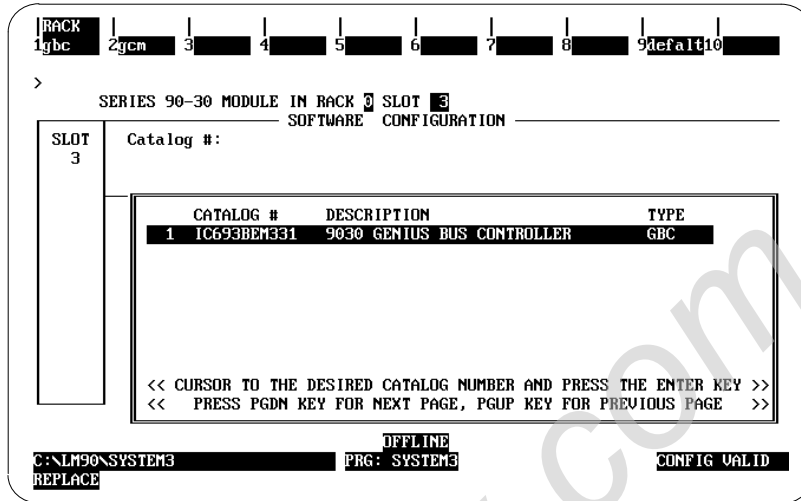

Press the **Enter** key to select the GBC. Complete the GBC configuration entries in the following screen.

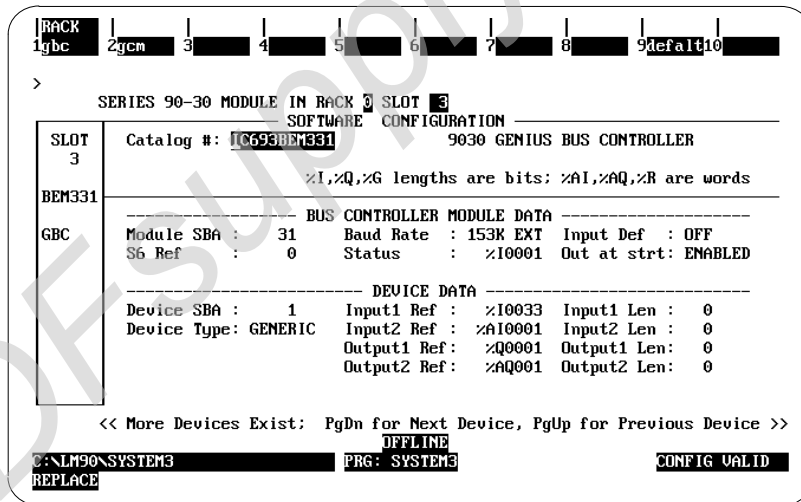

Note that the configuration screen consists of two parts: module-specific data (BUS CONTROLLER MODULE DATA) and device-specific data (DEVICE DATA). The default entries can be used as is, or changed. *Until a valid configuration is stored to the PLC CPU, the GBC will not operate on the bus, and its Channel OK LED will not light.*

Module-specific Data

Module SBA (serial bus address)	Ordinarily, the Device Number (bus address) assigned to a bus controller is 31. Any number from 0 to 31 can be used; however, each must be unique on that Genius bus (no configured device already present at that address). Whenever a Module SBA value is changed to a new value, the DEVICE DATA for the GBC associated with the old address is automatically copied to the new address value and cleared from the old address. <i>Default: 31</i>
Baud Rate	All devices on a bus <i>must</i> use the same baud rate: 153.6 Kbaud standard, 153.6 Kbaud extended, 76.8 Kbaud, or 38.4 Kbaud. Selection of a baud rate depends on the application, as explained in the <i>Genius® I/O System User's Manual</i> . Usually, the bus length determines the baud rate. The entry made here establishes the baud rate for the GBC <i>only</i> . If the default baud rate (153.6 Kbaud extended) will not be used, the baud rate of other devices on the bus must also be changed. Typically, this is done using a Hand-held Programmer. <i>Default: 153K STD</i>
Series Six (S6) Reference	The S6 reference specifies the register location in a Series Six or a Series Five CPU that should be reserved for the global data that will be transmitted to it by the GBC. A value of zero indicates that no register location should be reserved. The allowed range for Module Series Six Reference is 0 to 16383 inclusive. <i>Default: 0</i>
Status	This field contains the starting reference for the 32-bit status area maintained by the GBC. Each bit of this area represents the online / offline status of a device on the bus. <i>Default: Next available %I0001 address</i>
Input Def Out at strt	The input default state can be either set to HOLD or OFF. <i>Default: OFF</i> Device outputs can be initially ENABLED or DISABLED when the GBC is powered up. <i>Default: ENABLED</i>

Device-specific Data

A GBC module can support up to 31 devices on its bus. Each device will have the following parameters associated with it.

Device SBA A Device SBA can be between 0 and 31. Select by tabbing through the parameter, or by setting to the desired value. Pressing the **PgDn** key increments this parameter; pressing the **PgUp** key decrements this parameter. If you enter a Device SBA that is the same as the Module SBA, the input area parameters cannot be filled in and the Device Type will be fixed to CONTROL. *Default: 0*

Device Type Each device is associated with a device type. The device type selection can be tabbed through. The allowed device types and their associated input/output lengths are shown in the table on page 4-2. *Default: GENERIC*

If you select a Device Type other than GENERIC, the input and output starting references and lengths are automatically filled in. Fields that contain N/A represent 0. The length parameter can not be edited. In the following example screen, an %8I device type is configured at SBA 21.

```

RACK 1| 2| 3| 4| 5| 6| 7| 8| 9| 10
1|gbc| 2|gcm| 3| 4| 5| 6| 7| 8| 9|default| 10|
>
SERIES 90-30 MODULE IN RACK 1 SLOT 3
SOFTWARE CONFIGURATION
-----
SLOT 3 Catalog #: IC693BEM331 9030 GENIUS BUS CONTROLLER
BEM331 %I,%Q,%G lengths are bits: %AI,%AQ,%R are words
-----
GBC BUS CONTROLLER MODULE DATA -----
Module SBA : 31 Baud Rate : 153K EXT Input Def : OFF
S6 Ref : 0 Status : %I0001 Out at strt: ENABLED
-----
DEVICE DATA -----
Device SBA : 21 Input1 Ref : %I0033 Input1 Len : 8
Device Type: %2I Input2 Ref : N/A Input2 Len : N/A
Output1 Ref : N/A Output1 Len : N/A
Output2 Ref : N/A Output2 Len : N/A
<< More Devices Exist: PgDn for Next Device, PgUp for Previous Device >>
OFFLINE
C:\LM90\SYSTEM3 PRG: SYSTEM3 CONFIG VALID
REPLACE
  
```

GENERIC Devices

Note

For a device to be configured correctly using the generic device type, the number of input points (channels), and the number of output points configured must match exactly the amount of I/O the device is transmitting or expecting to receive. Otherwise, the device will be considered mismatched and the device's status bit will be set to off (0).

When using a GE Fanuc Genius I/O block, the Input 1 Ref and Output1 Ref must be set to the same starting address. Failure to set these addresses correctly can lead to Bus Controller errors and incorrect I/O mapping.

Note: For Input and Output Ref, the allowed memory types are %I, %AI, %Q, %AQ, %G, and %R.

**Input1 Ref/
Input2 Ref** A GENERIC device can be configured with two independent starting locations for input data with associated lengths for each location. The input data received from the device by the GBC is extracted and deposited into the PLC memory areas starting at these specified locations. *Default: next available %I reference*

**Input1 Len/
Input2 Len** Associated lengths for input starting locations, above. *Default: 0*

**Output1 Ref/
Output2 Ref** A device can be configured with two independent starting locations for output data with associated lengths for each location. The output data transmitted to the device by the GBC is extracted from the PLC memory areas starting at these specified locations. *Default: next available %I reference*

**Output1 Len/
Output2 Len** Associated lengths for input starting locations, above. *Default: 0*

Data from **Output1 Ref** will be sent to a device first, then data from **Output2 Ref** will be sent. Example:

Output1 Ref/Len = %Q1-16
Output2 Ref/Len = %R1-1

If the configured device is a 32-point output block, points 1-16 on the block are controlled by %Q1-16 and points 17-32 are controlled by %R1.

Data received as inputs from a device are placed first into **Input Ref1**, then into **Input Ref2**. Example:

Input1 Ref/Len = %I1-8
Input2 Ref/Len = %I33-41

If the configured device is a 16-point input block, points 1-8 on the block are put into %I1-8 and points 9-16 on the block are put into %I33-41.

After configuring all desired devices, press the **Esc** key to exit the detail configuration screens. The following screen will appear.

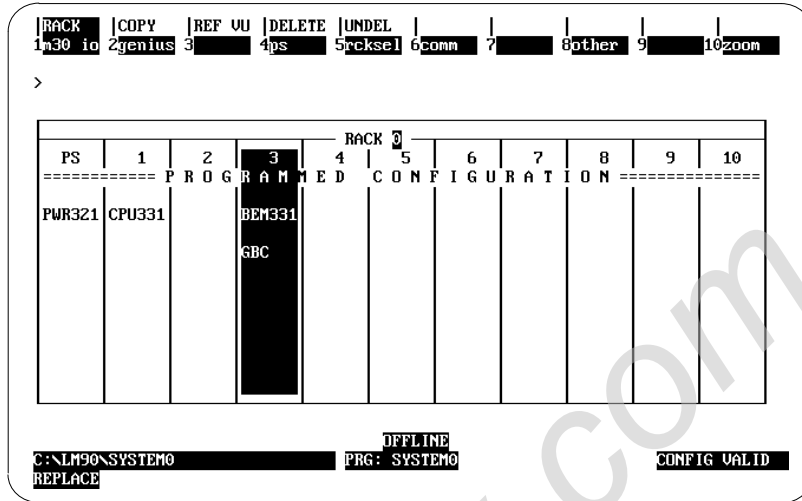

Entries in REF VU (Reference View Option)

The reference view screen can be entered by pressing the REF VU softkey (**shift F3**) in the rack menu. As shown in the example %I reference view screen below, every configured device that has %I memory configured has an entry. Here, the first entry corresponds to the Status Area of the GBC module with SBA 31. The second entry corresponds to the configured device 8%I with SBA 21. The third entry corresponds to a GCM+ module in slot 4 of the rack with SBA 16. Press the appropriate function key to see the other reference views: %Q (F4), %AI (F5), %AQ (F6), %R (F7), and %G (F8).

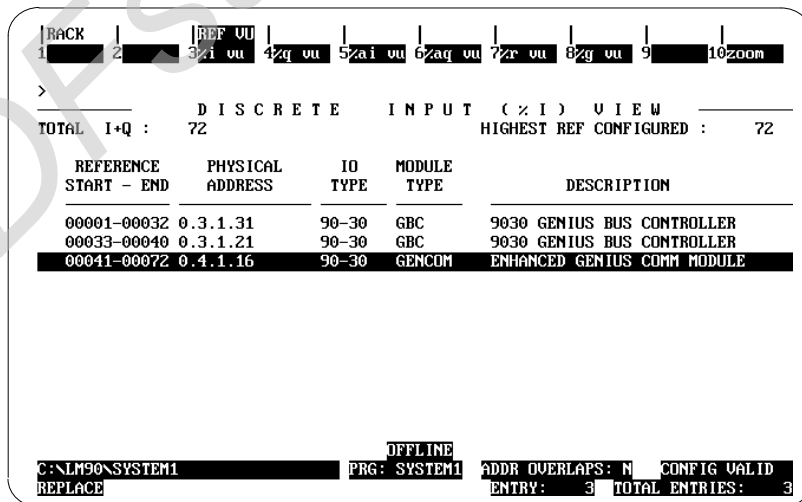

Configuration Using the Hand-held Programmer

With the GBC installed in its proper rack/slot location, a Hand-held Programmer can be used to configure the module in the offline mode. The Hand-held Programmer must be attached to and interfacing with the PLC. The PLC must be in Stop mode.

Hand-held Programmer Error Messages

The Hand-held Programmer will display a message if you make an error during configuration, or if the GBC is not present or not communicating with the host PLC.

REF ER	May indicate either of the following: A. The reference address assigned to that SBA exceeds the reference limit for the PLC model. B. The SBA message offset plus the length of the reference assigned to the SBA exceeds 128 bytes.
REF ADJ	May indicate either of the following: A. References have been adjusted (rounded) down to a byte boundary. B. For discrete references, the reference length for the SBA has been rounded up to a byte boundary.
IOM ERR	The GBC module has stopped responding.
I/O ERR	You have assigned reference addresses that overlap references already assigned.
DAT ERR	A parameter (such as the Series Six reference address) is out of bounds.
GCM ERR	A GCM has already been configured. A GBC can not be configured in this system.

Select the GBC

From the Program/Data screen, select module configuration by pressing the 4 key, then the ENTER key.

Press the **Down Arrow** key to reach the configuration screen for the rack and slot location of the GBC.

Use the HHP keypad to select the slot in which the GBC is installed. For example, if the GBC is to be configured in rack 0, slot 4, press the following keys in sequence: #, 0, ENTER, 4, ENTER. The following display will appear:

If the GBC is already configured, it appears in the slot location. For example:

```

R0:04 GBC 1.0 <S
I032:I0001-0032
  
```

The top line indicates the baseplate (R0) and slot (:04) selected. GBC stands for Genius Bus Controller. The number 1.0 identifies the firmware revision. The bottom line shows the addresses in %I memory that are assigned to the status bits.

If you press the → key, the following screen appears:

```

R0:04 GBC 1.0 <S
SBA: 31
  
```

Line 2 of the screen shows the module's Serial Bus Address (SBA).

If the GBC was not previously configured, but is present in the rack and slot, it does not appear at first. The HHP indicates that the slot is "empty".

```

R0:04 EMPTY <S
  
```

To add the GBC to the configuration, press the READ/VRFY and ENTER keys. The following screen, the first in a series of parameter configuration screens, appears:

```

R0:04 GBC 1.0 <S
I32:I_
  
```

Configure GBC-specific Parameters

Using the HHP, configure the following, pressing the **➡** key to go through the module parameters in sequence. Pressing the **-/+** key toggles through the values for the parameter being configured. Or, you can use the HHP keypad to enter a value. Press the **ENTER** **↵** key to actually make each selection. If you want to go back to an earlier parameter, use the **←** key.

GBC Status Reference

This field contains the starting reference for the 32-bit status area maintained by the GBC. Each bit of this area represents the online/offline status of a device on the bus.
Default: %I0001

- ▶ Enter the beginning reference in %I memory for the GBC module's 32 status bits. It is not necessary to enter leading zeros. After entering the number, press the **ENTER** **↵** key. The HHP displays the range of selected status bit addresses. For example:

```

RO:04 GBC 1.0 <S
I032:I0001-0032
  
```

Press the **➡** key to go to the next configuration screen.

GBC Bus Address

The following screen is used to configure the Bus Address (SBA) of the GBC.

- ▶ If the Bus Address shown is not correct, type in the new number from the keypad then press the **ENTER** **↵** key. Press the **➡** key to continue. Default: 31

```

RO:04 GBC 1.0 <S
SBA: 31
  
```

Baud Rate

The following screen can be used to change the baud rate for the GBC.

All devices on a bus *must* use the same baud rate: 153.6 Kbaud standard, 153.6 Kbaud extended, 76.8 Kbaud, or 38.4 Kbaud. Selection of a baud rate depends on the application, as explained in the *Genius I/O System User's Manual*. Usually, the bus length determines the baud rate. The entry made here establishes the baud rate for the GBC *only*. If the default baud rate (153.6 Kbaud extended) will not be used, the baud rate of other devices on the bus must also be changed. Default: 153K STD

```

RO:04 GBC 1.0 <S
BAUD: 153.6 EXT
  
```

- ▶ If the baud rate shown is not correct, press the **+/-** key to change it. When the correct baud rate appears, press the **ENTER** **↵** key. Press the **➡** key to display the next configurable feature of the module.

Series Six Reference

If there is a Series Six or Series Five PLC on the bus that should listen to the global data sent by the GBC, a beginning register address for the data must be supplied. The range of registers available for global data use is 1 to 16,383. The Series Five or Series Six PLC will figure out the length automatically. *Default: 0*

```

R0:04 GBC 1.0 <S
S6 REF: 0

```

- If there is a Series Five or Series Six PLC on the bus that should receive global data from the GBC, enter a register number here. Then press the ➡ key to continue.
- If a previously-configured Series Five or Series Six PLC should no longer receive global data from the GBC, enter 0.

Press the ➡ key to continue.

Input Default

The next selection determines how the GBC will respond if it loses communications with a device or devices. Data will either HOLD its last state, or be set to 0 (OFF). If the GBC stops receiving data from one or more devices on the bus, it applies the data default to the corresponding data being passed back to the CPU. *Default: OFF*

```

R0:04 GBC 1.0 <S
INPUT DEF: OFF

```

- If data should hold its last state when communications are lost, select HOLD. If data should be set to 0, select OFF. Press the -/+ key to make the selection, then press the ENTER ↵ key.

Outputs Powerup Enable/Disable

```

R0:04 GBC 1.0 <S
OUTPUTS:ENABLE

```

Device outputs can be initially ENABLED or DISABLED when the GBC is powered up. To change the outputs powerup parameter to DISABLE, press the -/+ key, followed by the ENTER ↵ key. *Default: ENABLE*

This completes the GBC module-specific portion of GBC configuration. The following screens are used to complete the device-specific portion of GBC configuration. Press the ➡ key to continue.

Configure Device-specific Parameters

A GBC module can support up to 31 devices on its bus. (One of the 32 bus addresses is used by the GBC module.) Enter the appropriate parameters for each serial bus address (SBA) that has a device assigned to it. (If there is no device configured at an SBA, the second line will read UNASSIGNED.)

Pressing the **➡** key will cause the next parameter for the SBA to be displayed. If you want to go back to an earlier address, use the **⬅** key.

```
R0:04 GBC 00I1<S
UNASSIGNED
```

GENERIC Devices

All devices entered using the HHP are of the Generic type.

Input1 Ref Type

A GENERIC device can be configured with two independent starting locations for input data with associated lengths for each location. The input data received from the device by the GBC is extracted and deposited into the PLC memory areas starting at these specified locations. You can change the reference type, by pressing the I/ AI, Q/ AQ, R, or G keys. When the desired reference type is displayed, press the **ENTER** **↵** key.

```
R0:04 GBC 00I1<S
%I_
```

Input1 Len

Length associated with Input1 Ref type, above. You can change the length, using the HHP keypad. When the desired length is displayed, press the **ENTER** **↵** key. Lengths should be entered as the number of bits for %I, %Q, %G and as the number of words for %AI, %AQ, and %R.

```
R0:04 GBC 00I1<S
%I8:_
```

Input1 Start Ref

Starting reference associated with Input1 Ref Type and Input1 Len, above. You can change the start reference using the HHP keypad. When the desired address is displayed, press the **ENTER** **↵** key.

```
R0:04 GBC 00I1<S
%I8: I001-008
```

Input2 Ref Type

See Input1 Ref Type.

Input2 Len

Length associated with Input2 Ref starting location, below.

Input2 Start Ref

Starting reference associated with Input2 Ref Type and Input2 Len, above.

Output1 Ref Type

A GENERIC device can be configured with two independent starting locations for output data with associated lengths for each location. The output data transmitted to the device by the GBC is extracted from the PLC memory areas starting at these specified locations. You can change the reference type by pressing the I/ AI, Q/ AQ, R, or G keys on the HHP keypad. When the desired reference is displayed, press the ENTER key.

```
R0:04 GBC 00I1<S
%Q
```

Output1 Len

Length associated with Output1 Ref starting location. You can change the length, using the HHP keypad. When the desired length is displayed, press the ENTER key. Lengths should be entered as the number of bits for %I, %Q, %G and as the number of words for %AI, %AQ, and %R.

```
R0:04 GBC 00I1<S
%Q8: _
```

Output 1 Start Ref

Starting location for output data. You can change the address, using the HHP keypad. When the desired address is displayed, press the ENTER key.

```
R0:04 GBC 00I1<S
%Q8: Q001-Q008
```

Output2 Ref Type

See Output1 Ref Type.

Output2 Len

Length associated with Output2 starting reference.

Output 2 Start Ref

See Output1 Start Ref.

Note

For a device to be configured correctly using the generic device type, the number of input points (channels), and the number of output points configured must match exactly the amount of I/O the device is transmitting or expecting to receive. Otherwise, the device will be considered mismatched and the device's status bit will be set to off (0).

Fault Table

Faults and alarms from I/O devices, Bus Controller faults, and bus faults are automatically logged into the Series 90-30 PLC's I/O Fault Table. Faults can be displayed in On-Line or in Monitor mode. GBC faults can not be cleared using the HHP.

Note that the 90-30 GBC does not provide **addn of device** or **loss of device** faults as the 90-70 PLC does. This information is contained in the status bits, which are also set to off (0) if there is a configuration or device mismatch. See page 2-3 for a discussion of status bits.

1 PROGRM	2 TABLES	3 STATUS	4	5 LIB	6 SETUP	7 FOLDER	8 UTILITY	9 PRINT	
1 plcrun	2 passwd	3 plcflt	4 io flt	5 plcmem	6 blkmem	7 refsiz	8 sweep	9 clear	0 zoom

>

I / O F A U L T T A B L E

TOP FAULT DISPLAYED: 0001	TABLE LAST CLEARED: 09-21 08:00:00
TOTAL FAULTS: 0007	ENTRIES OVERFLOWED: 0000
FAULT DESCRIPTION: OPEN WIRE	PLC DATE/TIME: 10-14 10:05:13

FAULT LOCATION	CIRC NO.	REFERENCE ADDR.	FAULT CATEGORY	FAULT TYPE	DATE M-D	TIME H: M: S
33#0.4	6	%AI010124	CIRCUIT FAULT	ANALOG FAULT	10-12	08:12:20

MAINPLC	RUN/ENABLE	7 MS SCAN	ONLINE	L4 ACC: WRITE CONFIG	CONFIG EQUAL
PLC C: LESSON		PRG: LESSON			
REPLACE					

Remote Drop Fault
Drop ID#, rack, slot

For a Genius bus fault, the display shows the date and time the fault occurred, and the following information:

- Fault Location:** For a Genius bus fault, the format is rack/slot/bus/busaddress. For a Remote Drop fault, the format is: Drop ID#/ rack/ slot.
- Circ No:** The relative position of a point within its module.
- Reference Addr:** The I/O reference address where the fault was detected. It consists of the memory type (%I, %Q, %IQ, %AI, %AQ) and a five-digit offset.
- Fault Category:** The general type of fault that has occurred. For diagnostic faults, the CPU sets fault references. For fatal faults, the CPU sets fault references and places itself in STOP mode.
- Fault Type:** Further explains fault categories: Circuit Fault, Module Fault, I/O Bus Fault, Loss of Block, and GBC Software Exception. These categories are defined in the table on page 5-4.
- Fault Description:** Provides additional information if the highlighted fault is one of the Circuit Faults or a Module Fault.

Number of Faults in the I/O Fault Table

The I/O Fault Table can contain up to 32 faults. Additional faults cause the table to overflow, and faults are lost. The system reference **IO_FULL** (%S00010) is set to indicate that the fault table is full.

As faults occur, the first 16 are logged into the table and remain there until the table is cleared again; none of these 16 faults will be dropped if the table overflows. For faults 17 through 32, the Fault Table operates as a First-In-First-Out stack. When fault 33 occurs, fault 17 is dropped from the table. Clearing the Fault Table removes all the fault listings.

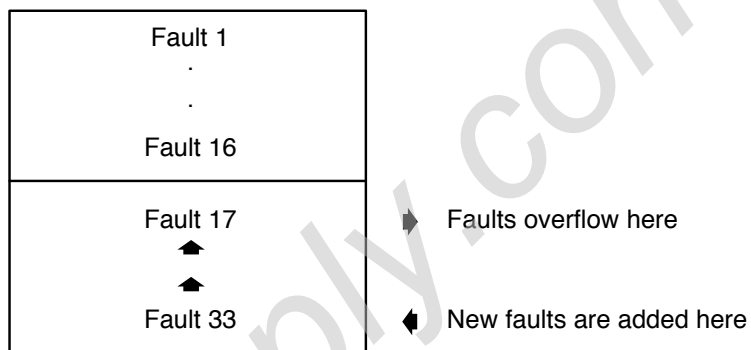

Clearing Faults

Faults can be cleared from the fault table using Logicmaster 90-30 (in the online mode), using a Hand-held Monitor on the Genius bus, or by sending a Clear All Faults datagram (see example on page 6-11). Clearing the fault table removes all fault entries.

Also, clearing faults only removes them from the table; it does not clear fault conditions in the system. If the condition that caused a fault still exists and is detected, the fault will be reported again.

Note

If you have a GCM+ and a 90-30 GBC in the same CPU system and on the same Genius bus, you must turn the report faults configuration parameter on the GCM+ to **no**. If you enable report faults on the GCM+ in such a system, a single fault that occurs on the Genius bus or inside the 90-30 system will be reported endlessly, causing the fault table to be filled with multiple reports of the same fault.

Fault Table Definitions

Fault Category	Diag. or Fatal	Indicates	Fault Type	Indicates	Fault Description	Indicates
CIRCUIT FAULT	D	Short circuit, open wire, etc.	DISCRETE FAULT	Circuit fault on discrete I/O point	LOSS POWER	Loss of user side power
					SHORTCIRCUIT	Short in user wiring
					OVERLOAD	Sustained overcurrent
					NO LOAD	Very low or no current flow
					OVERTEMP	Switch temperature too high
					SWITCH FAIL	Genius "smartswitch" failure
					POINT FAULT	Integral individual point fault
					FUSE BLOWN	Integral output fuse blown.
			ANALOG FAULT	Fault on analog I/O channel	AI LOW ALARM	Input channel low alarm
					AI HI ALARM	Input channel high alarm
					AI UNDER RANGE	Input channel under range
					AI OVER RANGE	Input channel over range
					OPEN WIRE	Open wire detected on input channel
					AQ UNDER RANGE	Output channel under range
					AQ OVER RANGE	Output channel over range
					CS FEEDBACK ERR	Feedback error from Current-source Analog block
			GENA FAULT	Fault on a GENA	GENA CKT FLT	Fault on a GENA analog or discrete point
			LL ANALOG FAULT	Fault on a low-level analog channel	AI LOW ALARM	Input channel low alarm
					AI HI ALARM	Input channel high alarm
					AI UNDER RANGE	Input channel under range
					AI OVER RANGE	Input channel over range
					OPEN WIRE	Open wire detected on input channel
					WIRING ERROR	improper RTD connection or thermocouple reverse junction fault
					INTERNAL FAULT	Cold junction sensor fault on thermocouple block, or internal error in RTD block.
			INPUT SHORT	Input channel shorted		
			REMOTE FAULT	Fault on a Remote I/O Scanner	n/a	Any fault detected by a Remote I/O Scanner and sent to the PLC.

Fault Table Definitions (continued)

Fault Category	Diag or Fatal	Indicates	Fault Type	Indicates	Fault Description	Indicates
I/OBUS FAULT	D	Genius bus fault	BUS FAULT	Genius bus fault		
			BUS OUT DISABLE	Bus Controller disabled all outputs on the bus because communications timed out between the PLC CPU and the Bus Controller		
I/O MODULE FAULT	D	EEPROM fault, watch dog timeout	HEADEND FAULT	Block Fault (EEPROM, Watchdog, etc..)	CONFIG MEM FAIL	Genius EEPROM or NVRAM failure
					CAL MEM FAIL	Genius calibration memory failure
					SHARERAM FAIL	Genius Shared RAM fault
					INTRNAL CKT FLT	Genius internal circuit fault
					WD TIMEOUT	Watchdog Timeout (discrete I/O modules only)
					POINT FAULT	Point fault (also indicated for CIRCUIT FAULT category)
					FUSE BLOWN	Integral output fuse blown (also indicated for CIRCUIT FAULT category)
			A TO D COMM FAULT	Analog to digital communications fault or calibration error		
			USER SCALING ERROR	Scaling error cause out of range values		

Additional Fault Information

If you need more information about a listing in the Fault Table, move the cursor to that fault and press the **CTRL** and **F** keys. A number string will appear above the command line. The *Series 90-30 PLC Installation and Operation Manual* (GFK-0356) explains how to interpret this additional fault information.

If you find it necessary to contact Field Service concerning a fault, you should be prepared to tell them the information that is provided in the Fault Table *and the hexadecimal information you see when you press the Ctrl/F keys*. Field Service personnel will give you further instructions.

Technical Help

PLCHotline	
Phone numbers	1-800-828-5747(or804-978-5747)
Internet address	PLCHOTLINE@CHO.GE.COM
Fax number	804-978-5099
GE Fanuc Bulletin Board	Files on this bulletin board are provided by GE Fanuc "as-is" and no warranties apply. The phone number is 804-978-5458 (up to 19200 baud, 8 bits, no parity).
Fax Link	804-978-5824

Chapter 6

Communication Requests

This chapter explains how to use Communication Requests (COMMREQs) to:

- Enable/disable all outputs from the GBC to devices on the bus
- Send a datagram to a device on the bus.
- Send a datagram containing a Reply Datagram Request to a device on the bus
- Transfer an unsolicited incoming datagram from the GBC to the CPU.

For additional information, see the *Genius® I/O System and Communications Manual* (GEK-90486-1), which describes Genius Datagrams in detail.

COMMREQs and Passwords

Level 1 and 2 Logicmaster passwords, which prevent write access, cannot be used in applications that include COMMREQs. COMMREQs require write access to return their completion status.

Programming for a Communication Request

In order to communicate with an intelligent module (such as a GBC), the application program should perform the following actions.

1. **Supply the content of the communication.** Block Moves or similar program instructions can be used to place the information into CPU memory. This content is called the Command Block.

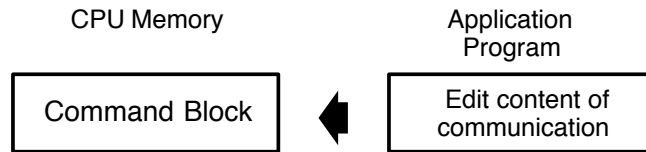

2. **Clear status block.** The program should set the status block to all zeroes (see page 6-9). Establishing this initial condition allows the program to differentiate between the result of an earlier command and the currently-executing command.

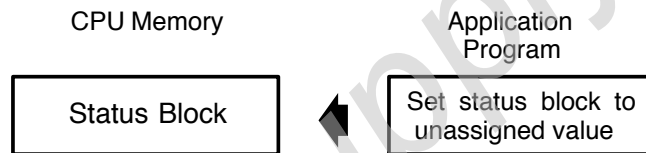

3. **Use a COMMREQ instruction** to perform the intended function.

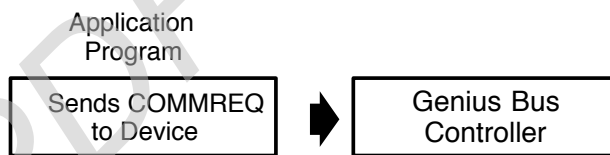

4. **Check the status of the requested task.** COMMREQs should be executed sequentially. The application program should check that the status of the previous COMMREQ to a GBC is complete, before sending it another one. Failure to do this may result in improper operation of the GBC.

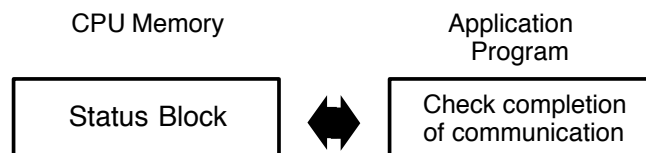

COMMREQ Command Block Format

The first step in programming communications requests is to set up the contents of the communication. This can be done using Block Moves or similar program instructions, as shown later in this chapter.

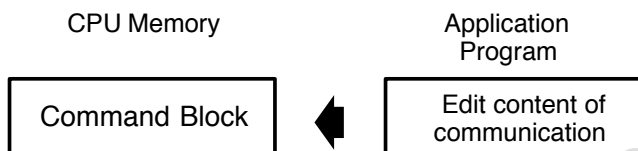

Data is placed together in adjacent locations in CPU memory to form a Command Block.

Location	Data
address	"Data Block" Length
address + 1	Wait/NoWait Flag
address + 2	Status Pointer Memory Type
address + 3	Status Pointer Offset
address + 4	Idle Timeout Value
address + 5	Max. Communication Time
address + 6 to address + 70	Data Block

The length of the Command Block depends on the type of COMMREQ being sent. Although 70 words is the maximum, for a COMMREQ that transfers a 128-byte datagram; most Command Blocks are much shorter. The table on page 6-5 gives an overview of the contents of each type of COMMREQ that may be sent to a Series 90-30 GBC.

Command Block Contents

Command Block contents are described below. Further details are given in the table on page 6-5.

Length: The first word of the Command Block indicates the "data block" length. This is the amount of data from **[address + 6]** to the end of the Command Block. Each type of COMMREQ command has a unique Data Block.

Wait/No Wait Flag: This must be set to 0 for No Wait.

Status Pointer Memory Type:

The Status Pointer Memory Type and Offset (see below) identify the location of the function's associated Status Block. The Status Block is where the COMMREQ will return its status. If one of the bit-oriented memories (%I or %Q) is used as the status location, its bits can be monitored (see page 6-9).

Location	Data
address + 1	Status Pointer Memory
address + 2	Status Pointer offset

The high byte of address + 2 of the pointer is not used; it must be zero. The low byte of address + 2 specifies the type of memory where the Status Pointer will be located.

For This Memory Type:		Enter This Number:
%I	discrete input table	70
%Q	discrete output table	72
%R	register memory	8
%AI	analog input table	10
%AQ	analog output table	12

Status Pointer Offset:

Address + 3 of the Command Block contains the address within the memory type selected. **The offset of the status location is 0-based.** For example, if the Status Block was located at %R099, memory type would be specified as 08 (for %R memory) and the offset would be 98.

Note that if a bit-oriented memory is specified, a byte boundary must be used for the offset.

Idle Timeout Value:

This field is not used for the No Wait mode of communication.

Maximum Communication Time:

This field is not used for the No Wait mode of communication.

Data Block:

The Data Block contains the parameters of the command. Complete descriptions of all commands appear later in this chapter (see pages 6-14 through 6-22). The Data Block begins with a Command Number in Address +6. The Command Number identifies the type of communications function to be performed. The following Command Numbers are used for the Genius GBC:

Command	Function
8	Enable/disable outputs command
13	Dequeue datagram
14	Send datagram
15	Request datagram reply

Command Block Quick Reference

The following table summarizes the content of the COMMREQ commands for a GBC.

COMMREQ Description	Command Block Content									
	Addr.	Addr.+1	Addr.+2	Addr.+3	Addr.+4	Addr.+5	Addr.+6	Addr.+7	Addr.+8	to Addr.+n
	Length	Wait/No Wait	Status Pointer Memory Type	Status Pointer Offset	Idle Timeout Value	Max. Comms. Time	COMMREQ #	Additional Content		
Outputs Enable, Disable (#8)	3	0	see page 6-14		0	0	8	see page 6-14	1 (enable) or 0 (disable)	see page 6-14
Dequeue Datagram (#13)	7	0	see page 6-15		0	0	13	Addr.+7 to Addr.+12 see page 6-15		
Send Datagram (#14)	6 to 70 words	0	see page 6-19		0	0	14	Addr.+7 to Addr.+n see page 6-19		
Request Datagram Reply (#15)	10 to 78 words	0	see page 6-22		0	0	15	Addr.+7 to Addr.+n see page 6-22		

The COMMREQ Instruction

After supplying the content of the communication in the Command Block, the application program uses a COMMREQ instruction to request communications with the GBC.

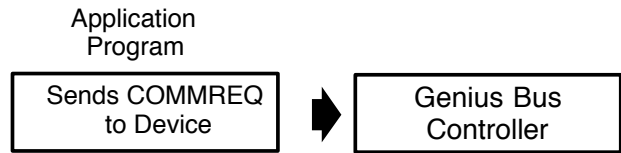

COMMREQ Inputs and Outputs

The COMMREQ instruction has four inputs and two outputs:

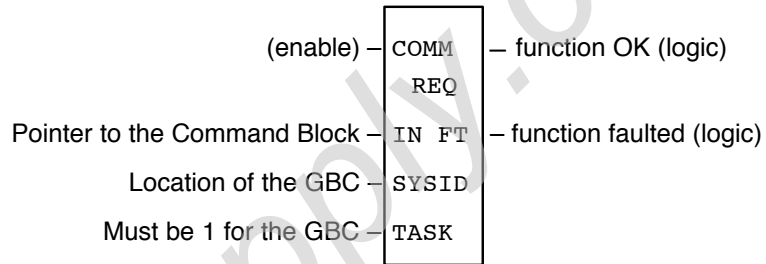

COMMREQ Inputs

- (enable)** Permissive logic that controls power flow to the COMMREQ function block.
- IN:** The memory location of the Command Block, which contains the specific command information. The Command Block may be located in any word-oriented area of memory (%P, %L, %R, %AI, or %AQ).
- SYSID:** A hex value that gives the rack and slot location of the GBC. Use this format:



Examples

Rack	Slot	Hex word value
0	4	0004h
7	2	0702h

TASK: The task is always "1".

COMMREQ Outputs

The function's OK and FT outputs can provide power flow to optional logic which can verify successful completion of the COMMREQ. The OK and FT outputs may have these states:

ENable	Error?	OK output	FT output
active	no	true	false
active	yes	false	true
not active	no execution	false	false

The OK and FT outputs are never both true at the same time; OK indicates correct execution while FT indicates a fault condition. The COMMREQ passes power flow to OK unless:

- The specified module (in rack / slot) is not present.
- The specified task is not valid for the device. This is not checked if the specified device is a GBC.
- The data length is zero.

If any fault above occurs, the function passes power flow to FT instead.

If there are errors in the portion of the Command Block used specifically by the GBC (for example, the Device Number entered is incorrect), these errors are reflected in the value returned in the status location, not in the FT output.

COMMREQ Status Block

When the GBC receives the communication from the CPU, it returns its current status to the CPU, at the two-word memory location reserved for the Status Block. Possible status values that can be returned are listed on the next page.

When a command is complete, the GBC writes any resulting data into the area designated in the command, and sets the status to Complete (4).

Note

Because COMMREQs require write access to return their status, level 1 and 2 Logicmaster software passwords, which prevent write access, cannot be used with COMMREQs. If an illegal memory type is specified, a fault will be generated.

If one of the bit-oriented memories (%I or %Q) is used as the status location, its bits can be monitored. These bits correspond to the binary values listed below. For example, if %I048 were selected as the beginning location, reference %I050 would be set to 1 each time the COMMREQ completed successfully.

Clearing the Status Block

COMMREQs to the GBC should be executed sequentially. Before sending a COMMREQ to the GBC, the application program should check the status of any previous COMMREQ to that GBC.

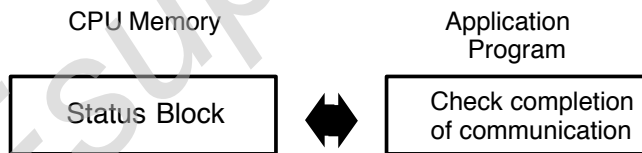

When the previous COMMREQ has completed, the program should set the Status Block to a value not in the list on the next page. Establishing this initial condition allows the program to differentiate between the result of an earlier command and the currently-executing command.

Contents of the Status Block

The Status Block is two words of memory to which the GBC returns the status of the COMMREQ.

The lower word is used for general information about the execution of the COMMREQ:

VALUE		DESCRIPTION
decimal (word)	binary (bit)	
	MSB	
0	000000000000	GBC has not yet processed COMMREQ
1	000000000001	Command not accepted, GBC busy with previous request
4	000000000100	Command completed successfully
8	000000001000	Command terminated due to syntax error
16	000000010000	Command terminated due to data error
32	000000100000	Command terminated due to suspended activity on bus
64	000001000000	No data to transfer
128	000010000000	Command not supported by target device
256	000100000000	Only No Wait commands may be sent to the target device
512	001000000000	Maximum Comms. Time must be greater than or equal to 5mS
1024	010000000000	Text buffer invalid in wait mode
2048	100000000000	Device did not accept the message, or timed out.

The upper word of the status location provides additional status information.

VALUE decimal (word)	DESCRIPTION
11	Non-discrete block specified for Pulse Test
21	Non-I/O devices specified for Read Configuration
51	Invalid circuit number
71	Non-controller device specified for Assign Monitor
101	Switch BSM - device not BSM
102	Switch BSM - bus position greater than 1
121	P and L access not available
141	Function code greater than 111
142	Sub function code greater than 255
143	Priority greater than 1
144	Datagram length greater than 134
201	Invalid Device Number (greater than 31, but not 255)
202	Incorrect length for the command type
203	Device Number not configured or not active
204	Previous No Wait command in progress; current No Wait command not accepted
205	Invalid status pointer location specified
206	Command number is out of range
207	Subcommand code is out of range
208	Only partial data transferred
209	Device Number 255 not allowed for this command
210	Command specified is not valid for GBC
211	Command specified is only valid for controller devices
212	Command specified is not supported by the device to which it was sent
213	Invalid Alarm Enable/Disable mask

Using COMMREQs to Send Datagrams

The table on page 6-13 lists datagrams with their Subfunction Codes, lists possible ways to send datagrams, and explains what happens to datagrams received from other devices.

COMMREQ 14 (Send Datagram) and COMMREQ 15 (Request Datagram Reply) are the only way to send messages to or from the GBC. Also, COMMREQ 13 (Dequeue Datagram) must be used to handle datagrams that are not handled automatically.

All datagrams can be sent using COMMREQ 14 (Send Datagram). If COMMREQ 14 is used to send a datagram that has a reply, COMMREQ 13 (Dequeue Datagram) must also be used to obtain the reply from the GBC's queue of unsolicited incoming datagrams.

Using COMMREQs to Send Datagrams

Datagram (hex code)	Ways to Send It	How Incoming Datagram is Handled
Read ID (00)	COMMREQ 15 (Request Datagram Reply) *	GBC replies automatically to Read ID datagram received from bus device.
Read ID Reply (01)	(Sent automatically)	Handled automatically if COMMREQ 15 was used to send Read ID datagram. *
Read Configuration (02)	COMMREQ 15 (Request Datagram Reply) *	GBC queues it up. Use COMMREQ 13 (Dequeue Datagram) to read it.
Read Configuration Reply (03)	(Sent automatically)	Handled automatically if COMMREQ 15 was used to send Read Configuration datagram. *
Write Configuration (04)	COMMREQ 14 (Send Datagram)	GBC queues it up. Use COMMREQ 13 (Dequeue Datagram) to read it.
Assign Monitor (05)	COMMREQ 14 (Send Datagram)	
Begin Packet Sequence (06)	COMMREQ 14 (Send Datagram)	
End Packet Sequence (07)	COMMREQ 14 (Send Datagram)	
Read Diagnostics (08)	COMMREQ 15 (Request Datagram Reply) *	GBC replies automatically.
Read Diagnostics Reply (09)	(Sent automatically)	Handled automatically if COMMREQ 15 was used to send Read Diagnostics datagram. *
Write Point (0B)	COMMREQ 14 (Send Datagram)	GBC queues it up. Use COMMREQ 13 (Dequeue Datagram) to read it.
Read Block I/O (0C)	COMMREQ 15 (Request Datagram Reply) *	Handled automatically if COMMREQ 15 was used to send Read Block I/O datagram. *
Read Block I/O Reply (0D)	(Sent automatically)	
Report Fault (0F)	(Sent automatically)	Received from bus devices; GBC automatically places the fault in the Fault Table.
Pulse Test (10)	COMMREQ 14 (Send Datagram)	GBC queues it up. Use COMMREQ 13 (Dequeue Datagram) to read it.
Pulse Test Complete (11)	(Sent automatically)	Handled automatically if COMMREQ 14 was used to send Pulse Test datagram. *
Clear Circuit Faults (12)	COMMREQ 14 (Send Datagram)	GBC queues it up. Use COMMREQ 13 (Dequeue Datagram) to read it.
Clear All Circuit Faults (13)	COMMREQ 14 (Send Datagram)	
Switch BSM (1C)	COMMREQ 14 (Send Datagram)	
Read Device (1E)	COMMREQ 15 (Request Datagram Reply)	GBC automatically sends reply.
Read Device Reply (1F)	(Sent automatically)	Handled automatically if COMMREQ 15 was used to send Read Device datagram. *
Write Device (20)	COMMREQ 14 (Send Datagram)	GBC processes automatically.
Read Data (27)	COMMREQ 15 (Request Datagram Reply)	GBC queues it up. Use COMMREQ 13 (Dequeue Datagram) to read it.
Read Data Reply (28)	(Sent automatically)	Handled automatically if COMMREQ 15 was used to send Read Data datagram. *
Write Data (29)	COMMREQ 14 (Send Datagram)	GBC queues it up. Use COMMREQ 13 (Dequeue Datagram) to read it.
Read Map (2A)	COMMREQ 15 (Request Datagram Reply)	
Read Map Reply (2B)	(Sent automatically)	Handled automatically if COMMREQ 15 was used to send Read Map datagram.
Write Map (2C)	COMMREQ 14 (Send Datagram)	GBC queues it up. Use COMMREQ 13 (Dequeue Datagram) to read it.

* All datagrams can be sent using COMMREQ 14 (Send Datagram). If COMMREQ 14 is used to send a datagram that has a reply, COMMREQ 13 (Dequeue Datagram) must also be used to obtain the reply from the GBC's queue of unsolicited incoming datagrams.

COMMREQ Descriptions

COMMREQ #8: Enable/Disable Outputs Command

The Enable/Disable Outputs command can be sent to the GBC to disable sending outputs *to any block*.

Command Block for the Enable/Disable Outputs Command

Address:	CommandLength	3
Address +1:	No Wait	0
Address +2:	Status Block memory type	70 (%I), 72 (%Q), 8 (%R), 10 (%AI), or 12 (%AQ)
Address +3:	Status Block offset	Beginning address for the COMMREQ status.
Address +4:	Idle timeout value	0
Address +5:	Max. communications time	0
Address +6:	Command number	8
Address +7:	Device Number	Enter 0–31 to enable or disable outputs to one block. To enable or disable outputs to ALL devices on the bus, enter the number 255.
Address +8:	Enable/Disable command	To disable outputs to the device(s) specified in address +7, enter 0. To enable outputs, enter 1.

Note that this COMMREQ overrides the configuration parameter **outputs enable/disable at start**. For example, if outputs were initially disabled to all blocks during configuration, this COMMREQ could be used to enable outputs to specific devices or to all devices.

COMMREQ #13: Dequeue Datagram Command

The GBC handles most incoming datagrams automatically, with no additional programming required. Under certain circumstances, however, the Dequeue Datagram command must be used to transfer incoming datagrams to the CPU. Program the Dequeue Datagram command for the following:

- Replies that are received after sending Reply-type datagrams with the Send Datagram command. (If Send Datagram with Reply is used instead, it automatically handles replies).
- Unsolicited datagrams that are not recognized by the GBC (Function Code not 20).

Command Block for the Dequeue Datagram Command

Location	Parameter	Contents
Address	CommandLength	7
Address +1:	No Wait	0
Address +2:	StatusBlock memory type	70 (%I), 72 (%Q), 8 (%R), 10 (%AI), or 12 (%AQ)
Address +3:	StatusBlock offset	Beginning address for the COMMREQ status.
Address +4:	Idle timeout value	0
Address +5:	Max. communication time	0
Address +6:	Command number	13
Address +7:	Maximum data memory length	Enter bit or word value (depends on the memory type selected below). This entry tells the CPU how much memory will be needed to store all the data. If the length of data returned by the device exceeds this length, the GBC writes as much data as possible to the PLC CPU and returns a data error to the COMMREQ status location.
Address +8:	Memory type	Enter the number that represents the location where the GBC will place the data in the CPU: 70 (%I), 72 (%Q), 8 (%R), 10 (%AI), or 12 (%AQ)
Addresses 9–12	Not used	Not used

Number of Dequeue Datagram Commands Needed

One Dequeue Datagram command is needed for each incoming datagram. If multiple incoming Datagrams are expected during one CPU sweep, it will be necessary to place multiple Dequeue Datagram commands in the program to assure their efficient transfer to the CPU.

The number of Dequeue Datagram commands needed depends on whether the Datagrams have been sent using Normal or High Priority, and the relative lengths of the CPU sweep time and the scan time of the bus, as explained below.

If the Bus Scan Time is Greater than the CPU Sweep Time

If all Datagrams on the bus are sent with Normal Priority, there is a limit of one incoming Datagram per CPU sweep. Therefore, only one Dequeue Datagram command per sweep will be needed to handle incoming Datagrams.

If all Datagrams on the bus are sent with High Priority, the GBC can potentially receive one Datagram from each transmitting device during a scan. The program should include the same number of Dequeue Datagram commands as incoming Datagrams. (See page 6-19 for a description of datagram priority.)

If the Bus Scan Time is Less than the CPU Sweep Time

If the bus scan time is significantly shorter than the CPU sweep time, you can estimate the number of Dequeue Datagram commands that must be sent to the GBC to accommodate incoming Datagrams on that bus.

First, determine how many scans can occur in one CPU sweep. For example, if the bus scan were 20mS and the CPU sweep were 90mS, the ratio between them would be 4.5 to 1. This should be rounded upward to 5.

This is the maximum number of Normal Priority Datagrams that might be received in a single CPU sweep. Plan to have the same number of Dequeue Datagram commands to that GBC in the program to handle the incoming Datagrams.

For High Priority Datagrams, multiply the number found above by the total number of devices on the bus that might send a High Priority Datagram to the GBC in one bus scan. This is the total number of incoming Datagrams from that bus the program might have to handle in a single CPU sweep. Plan on this number of Dequeue Datagram commands to the GBC.

Additional Logic for Incoming Datagrams

The GBC can place up to 16 datagrams into an internal queue. These include any unsolicited reply-type datagrams. This permits the program to, for example, send a Read ID Send Datagram and dequeue the Read ID Reply with the Dequeue Datagram COMMREQ.

If the 16-item queue becomes filled, an informational fault GBC_SOFTWR_EXCPTN is logged (Fault Type is DQ_QUEUE_FULL) in the I/O Fault Table. If the Dequeue Datagram is issued and there are no datagrams in the queue, the Status Pointer is set to NO DATA TO TRANSFER.

Program logic should be used to assure that no datagrams are accidentally written over. This might be done by copying each datagram to another memory location, or by changing the data memory location specified in the Command Block after each incoming datagram is received.

Note that the Dequeue Datagram queue is operated as a first-in-first-out (FIFO) queue. Specific datagrams within the queue can not be dequeued without first dequeuing datagrams received earlier. This feature is different from the Series 90-70 GBC operation.

Format of Returned Data

The Dequeue Datagram returns data in the following format.

Location	High Byte	Low Byte
Memory Address	Data Length	Status byte
Memory address +1	Subfunction code	Function code
Memory address +2	Data byte 2	Data byte 1
↓	↓	↓
↓	↓	↓
↓	↓	↓
Memory address +69	Data byte 134	Data byte 133

Returned Data items are explained below.

Status Byte: The status byte reports the Device Number of the device that sent the datagram. It also indicates whether the message was broadcast or directed by the other device.

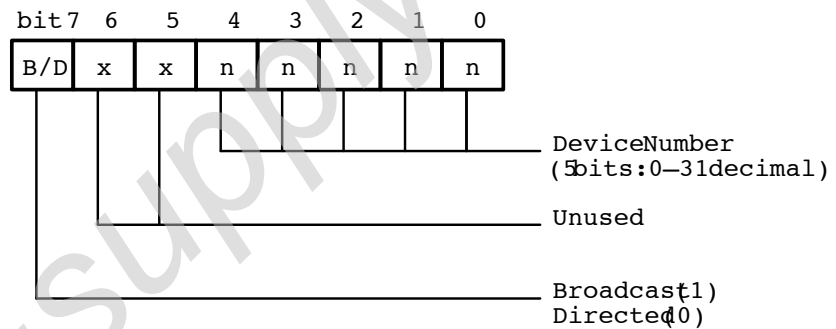

Data Length: The number (0 to 134) of data bytes after the subfunction code.

Function Code: The function code of the received message: 0 to 111 decimal or 0 to 6F hex.

Subfunction Code: The subfunction code of the received message: 0 to 255 decimal or 0 to FF hex.

COMMREQ #14: Send Datagram Command

Most datagrams are normally programmed using their assigned COMMREQ command numbers. However, datagrams can also be sent using the Send Datagram command and the Request Datagram Reply command. The Send Datagram command might be used to send:

- Datagrams for which no COMMREQ command number is defined, such as Begin Packet Sequence, End Packet Sequence, and Write Point.
 - Read Device and Write Device datagrams that are broadcast, but which should be ignored by another Series 90-30 GBC.
 - Datagrams that must be guaranteed transmission during the next bus scan. This should be done with restraint, for the reasons explained on the following pages.
 - Datagrams which do not cause another device to send back a reply, such as Pulse Test, or Write Configuration.
 - Messages that the 90-70 GBC has COMMREQs for, but the 90-30 GBC does not
- Datagrams which DO cause another device to send back a reply, such as Read Diagnostics or Read Configuration, are usually programmed using their assigned COMMREQ numbers or the Request Datagram Reply command (COMMREQ #15). However, if Send Datagram is used to send datagrams that cause replies, the Dequeue Datagram command must be used to transfer the replies back to the CPU.

Before using Send Datagram, refer to the table on page 6-12 for more information about COMMREQs and datagrams.

Command Block for the Send Datagram Command

Address:	Command Length	6 – 70. Enter the number of words from Address +6 to Address +n.
Address +1:	No Wait	0
Address +2:	Status Block memory type	70 (%I), 72 (%Q), 8 (%R), 10 (%AI), or 12 (%AQ)
Address +3:	Status Block offset	Beginning address for the COMMREQ status.
Address +4:	Idle timeout value	0
Address +5:	Max. communication time	0
Address +6:	Command number	14
Address +7:	Device Number of the device to receive the message.	0–31, or 255 to broadcast the message.
Address +8:	Function code	For any datagram listed below, 32 decimal (20 hex).
Address +9:	Subfunction code (hex)	See the list on page 6-12.
Address +10:	Priority	Enter 0 for normal priority, or 1 for high priority.
Address +11:	Datagram length (in bytes)	Enter the actual length of the Datagram, beginning at [address +12].
Address +12: to Address +n:	Datagram content	Enter the entire datagram as part of the Command Block. The <i>Genius I/O System User's Manual</i> shows datagram structures. <i>If the Send Datagram command is used to broadcast a Write Device datagram, and that datagram should be IGNORED by another Series 90-30 GBC, set the first byte of the datagram as shown in the System User's Manual (this byte is normally 0), to FE hex.</i>

Datagram Priority

A GBC can send one datagram per bus scan. That datagram may be assigned either normal priority or high priority. Therefore, during one bus scan, there may be one normal priority datagram followed by up to 31 high priority datagrams, or up to 32 high priority datagrams sent by the devices on the bus.

In one bus scan (one complete rotation of the bus token among all devices on the bus), there can be only one normal priority datagram sent by any device. If a normal priority datagram or similar system message (such as a fault report) has already been sent by any device (including itself), a device must wait until its next turn on the bus before it can send a normal priority datagram.

Datagrams and I/O Blocks

If the bus will also be used for I/O block control, normal priority datagrams are recommended to allow other messages such as fault reports (which the system handles as normal priority datagrams) to get through. In addition, normal priority datagrams ensure that bus scan time is only modestly delayed for communications. Bus scan time affects the response time of any I/O data on the bus. If there are I/O blocks on the bus, use high priority only if the datagram transmission cannot be delayed. Normal priority will work satisfactorily except when there are many devices attempting to send datagrams simultaneously.

Number of Datagrams per CPU Sweep

The application program should include logic that verifies successful completion of earlier datagrams before requesting new ones. Because a GBC can only send one datagram per bus scan, the number of datagrams that can be executed during the same CPU sweep of program logic depends on the relative lengths of the CPU sweep and the bus scan.

If the Bus Scan Time is Greater than the CPU Sweep Time: If the bus scan time is greater than the CPU sweep time, the GBC will be able to send no more than one datagram during one execution of the application program. Successful transmission of a normal priority datagram will depend on the absence of datagram and system message traffic on the bus.

If the Bus Scan Time is Less than the CPU Sweep Time: If the bus scan time is significantly shorter than the CPU sweep time, the bus may be able to transmit multiple datagrams during one execution of the application program.

Effect of Datagrams on the Genius I/O Bus Timing: Normal Priority Datagrams allow fault reports and Hand-held Monitor communications on a bus to continue undisturbed. Only one Normal Priority Datagram is allowed each bus scan, so the scan time stays relatively constant, and I/O update timing varies only by small increments.

If High Priority Datagrams are being transmitted constantly, the Hand-held Monitor will not function properly; fault reports from blocks will be prevented from being transmitted on the bus, and regular COMMREQ commands (such as Write Configuration commands) to that GBC will fail with a transmission error. For these reasons, use of High Priority Datagrams on a bus with I/O blocks should be avoided if possible.

If High Priority Datagrams are transmitted infrequently, they will cause some delay in the Hand-held Monitor communications and other normal system messages, but the delay should not be noticeable.

High Priority Datagrams will typically put more pressure on the GBC to transfer multiple Datagrams per CPU sweep. However, this can also occur with Normal Priority Datagrams if the bus scan time is much shorter than the CPU sweep time.

Maximum CPU Sweep Time Increase for Datagrams: To estimate the impact of Datagrams on CPU sweep time, add together the times required for all Datagrams that might be sent between the GBC and the CPU during one sweep if No Wait mode is selected. Repeat this for each GBC in the PLC that sends or receives Datagrams.

	Total Datagram Bytes Sent (may be none)	x	.031mS	=	
+	LARGEST incoming Normal Priority Datagram Received, bytes	x	.031mS	=	
OR					
+	Total incoming High Priority Datagrams Bytes Received	x	.031mS	=	
+			1.200mS	=	_____mS

Additional Information about Timing

If you need more information about timing for datagrams, Global Data, I/O devices, and remote drops, refer to the *Genius® I/O System User's Manual* (GEK-90486-1).

PDFSupply.com

COMMREQ #15: Request Datagram Reply Command

The Request Datagram Reply command can be used to send any datagram that causes the target device to return a reply, such as: Read Configuration or Read Diagnostics. With this command, the GBC automatically transfers replies to the CPU; no separate Dequeue Datagram command is needed to handle them.

These datagrams are normally programmed using their assigned COMMREQ command numbers. The primary reason for sending any of these datagrams using COMMREQ #15 would be to assign it high priority, guaranteeing that it would be sent on the next bus scan. Before doing this, see page 6-19 for important information about datagram priority.

Command Block for the Request Datagram Reply Command

Address:	Command Length	10 – 78. Enter the number of words from Address +6 to Address +n.
Address +1:	No Wait	0
Address +2:	Status Block memory type	70 (%I), 72 (%Q), 8 (%R), 10 (%AI), or 12 (%AQ)
Address +3:	Status Block offset	Beginning address for the COMMREQ status.
Address +4:	Idle timeout value	0
Address +5:	Max. communications time	0
Address +6:	Command number	15
Address +7:	Device Number of the device to receive the message.	0 – 31
Address +8:	Function code	For any datagram listed below, 32 decimal (20 hex).
Address +9	Subfunction code (hex) of the datagram to be sent.	00 Read ID 02 Read Configuration 08 Read Diagnostics 0C Read Block I/O 1E Read Device 27 Read Data
Address +10	Priority	Enter 0 for normal priority, or 1 for high priority.
Address +11:	Datagram length (in bytes)	Enter the actual length of the Datagram, beginning at [address +16].
Address +12:	Subfunction code (hex) of the reply	01 Read ID Reply 03 Read Configuration Reply 09 Read Diagnostics Reply 0D Read Block I/O Reply 1F Read Device Reply 28 Read Data Reply
Address +13:	Memory type for the reply	Enter a number: 8 (%R), 10 (%AI), or 12 (%AQ)
Address +14:	Memory offset	Starting address within this memory type.
Address +15:	Maximum data memory length needed If the length of the memory is smaller than the amount of reply data received, the extra portion of the data will be lost, and a data error (16) will be returned to the status location.	Enter a value in bits or words, depending on the memory type selected. This entry tells the CPU how much memory will be needed to store all the reply data. The length depends on the message and device type. – for Read Configuration Reply, see COMMREQ #2. – for Read Diagnostics Reply, see COMMREQ #4. – for Read Device Reply, message length depends on device type. May be up to 64 words. – for Read Data Reply, message length is 5 words. – for Read ID Reply, message length depends on device type. See the <i>Genius I/O System User's Manual</i> .
Address +16 to Address +n:	Datagram Content	Enter the entire datagram as shown in the <i>Genius I/O System User's Manual</i> .

Format of Returned Data

Returned data format is the same as for the Dequeue Datagram. See page 6-17.

A

A to D Comm fault, 5-5
 AIHi/LowAlarm fault, 5-4
 AIUnder/Overrange fault, 5-4
 Analog faults, 5-4
 AQUnder/Overrange fault, 5-4

B

Baud rate, 1-8, 4-5
 configuration, 4-11
 Bulletin board, 5-6
 Bus
 cable characteristics, 1-10
 cable types, 1-8–1-10
 how to disconnect, 3-5
 installation, 3-6
 length, 1-8
 noise, 3-5
 removal, 3-5
 termination, 1-8, 3-8
 using other cable types, 1-10
 Bus address, 4-5
 Bus controller, operation, 1-11
 Bus error rate, 5-3
 Bus fault, 5-5
 Bus Out Disable fault, 5-5
 Bus scan, 6-16
 description, 1-11, 2-6
 reducing time of, 2-11
 Bus scan time, 6-20

C

Cable types
 characteristics, 1-10
 high temperature, 1-9
 prefabricated, 1-10
 recommended, 1-9
 Cal Mem fault, 5-5
 Catalog numbers
 cables
 IC660BLC001, 1-10
 IC660BLC003, 1-10

CPU, 1-7
 GBC, IC693BEM331, 1-1, 1-6
 Genius Bus Interface Unit,
 IC760GBI001, 1-4
 Hand-Held Programmer, IC693PRG300,
 1-7
 HHM, IC660HHM501, 1-7
 inline HHM port, 44A736310-001-R001,
 1-7, 3-11
 mounting plate, IC660MPH509, 3-13
 Series Six Bus Controller,
 IC660CBB902F/903F1-7
 software, 1-7

Circuit faults, 5-4
 Circuit number, 5-2
 Clearing faults, 5-3, 6-10
 Comm OK, LED, 1-5
 Command block, COMMREQ, 6-3
 Command numbers, 6-4
 COMMREQ
 command block, 6-3
 command numbers, 6-4
 commands
 Dequeue Datagram, 6-5, 6-13, 6-15
 Outputs Enable/Disable, 6-5, 6-13
 Outputs Enabled, 6-14
 Request Datagram Reply, 6-5, 6-13,
 6-22
 Send Datagram, 6-5, 6-13, 6-18
 examples, 6-10–6-12
 inputs, 6-7
 instruction, 6-6
 outputs, 6-7
 quick reference, 6-5
 Status Block, 6-8–6-11
 status pointer, 6-4
 COMMREQs and Passwords, allowable
 password levels, 6-1
 Communication Request. *See* COMMREQ
 Communications, stopped, 2-3, 2-5
 Compatibility, 1-2, 1-7
 Computer, receives global data from GBC,
 2-12
 Config Mem fault, 5-5
 Configuration
 devices, 4-11
 generic devices, 4-7, 4-13
 I/Oblocks, 4-1
 remote drops, 4-1

using Hand-held Programmer, 4-9–4-15
using Logicmaster 90 software, 4-3–4-15
Connector, Hand-held Monitor, 3-11
CPU sweep, 2-2, 6-16, 6-20
CS Feedback Error fault, 5-4

D

Data block, 6-4
Data default, 2-3
Data quantities, 1-4
Datagrams, 1-14
 incoming, 6-12, 6-16
 number per CPU sweep, 6-20–6-21
 priority, 6-16, 6-18, 6-19
 ways to send, 6-12, 6-18
Default, input state, 4-5
Definitions, faults, 5-4
Dequeue Datagram COMMREQ, 6-5, 6-15
Device number, 4-5
Device outputs, enabled / disabled at start-up, 4-5, 4-12
Device type, 4-6
Diagnostics, 1-13, 5-1–5-7
Discrete faults, 5-4
D-shell connector, installing, 3-13

E

E-mail address, 5-6
Enable / Disable Outputs COMMREQ, 6-14
End of bus, terminating, 3-12, 3-13
Error messages, Hand-held Programmer, 4-9
Errors, number on bus, 4-4

F

Fault table, 5-2
Faults
 categories, 5-2

clearing, 5-3, 6-10
descriptions, 5-2
finding additional information about, 5-5
identification, 5-4
illegal memory type, 6-8
location, 5-2
number of, 5-3
types, 5-2

FieldcontrolI/O, 1-2

Field Control station, 1-4

Fuse Blown fault, 5-4, 5-5

G

GBC. *See* Genius Bus Controller
GCM. *See* Genius Communications Module
GE Fanuc bulletin board, 5-6
GENA faults, 5-4
Generic devices, configuring, 4-7, 4-13
Genius blocks, 1-2, 1-3
Genius Bus Controller
 description, 1-5
 number in system, 1-2
 operation, 1-11
 specifications, 1-6
Genius bus scan, description, 1-11
Genius Communications Module, 1-2, 2-12
 receives global data from GBC, 2-12
Genius Hand-held Monitor, compatibility, 1-7
GeniusI/O blocks, compatibility, 1-7
Global data, 1-15
 memory types, 2-1
 operation, 2-2, 2-5
 sending and receiving, 4-2

H

Hand-held Monitor, 1-2
 connector, 3-11
Hand-held Programmer, compatibility, 1-7
Headend fault, 5-5

I

I/O blocks, 1-2, 1-3
 compatibility, 1-7
 configuration, 4-1
 on bus, 2-12

I/O bus fault, 5-5

I/O data, 1-4

I/O Fault Table capacity, 5-3

Illegal memory type fault, 6-8

Input default state, 4-5

Input Short fault, 5-4

Inputs and outputs, 1-11, 1-12

Installation, Genius Bus Controller,
 3-4-3-5

Internal fault, 5-4

Intrnal Ckt fault, 5-5

Isolation, 1-8

L

LEDs
 Channel OK, 4-4
 Comm OK, 1-5
 Module OK, 1-5

LL Analog faults, 5-4

Location, Genius Bus Controller, 3-2, 3-4

Logicmaster 90 software, configuration
 with, 4-3

Logicmaster 90-30 software, compatibility,
 1-7

Loss Power fault, 5-4

M

Memory, for I/O blocks, 1-3

Memory types, for global data, 1-6, 2-1
 in other hosts, 2-12

Modulation technique, 1-8

Module, Genius Bus Controller, descrip-
 tion, 1-5

Module OK, LED, 1-5

N

No Load fault, 5-4

No Wait mode, 6-4

O

Open Wire fault, 5-4

Operation, Genius Bus Controller, 1-11

Output data, operation, 2-4

Outputs Enable; Disable COMMREQ, 6-5,
 6-14

Outputs enable/ disable at start, override,
 6-14

Over Temp fault, 5-4

Overload fault, 5-4

P

Passwords, Levels suitable for COMM-
 REQs, 6-1

Phone numbers, 5-6

PLC Hotline, 5-6

PLC sweep, scan time contributions, 2-7

Point fault, 5-4, 5-5

Priority, datagram, 6-16, 6-19

Programming for a COMMREQ, 6-2

R

Racks, installing GBC in, 3-4-3-7

Read Configuration datagram, 6-22

Read Data datagram, 6-22

Read Device datagram, 6-22

Read Diagnostics datagram, 6-22

Reference address, 5-2

Reference view, 4-8

Remote drop, memory required for, 1-4

Remote drops, 1-2
 configuration, 4-1

Removing the module, 3-5

Request Datagram Reply COMMREQ,
 6-5, 6-22

S

- S6. *See* Series 6; Series Six
- SBA, 4-6, 4-11
 - See also* Bus address
 - configuring devices for, 4-13
- Scan time contributions, 2-7
- Selecting a cable type, 1-8–1-10
- Send Datagram COMMREQ, 6-5, 6-18
- Serial Bus Address. *See* SBA
- Series 90-30 PLC, receives global data from GBC, 2-12
- Series 90-30 PLC, compatibility, 1-7
- Series Five PLC
 - See also* Series Six PLC
 - reference address, 4-12
- Series Six PLC
 - compatibility, 1-7
 - receives global data from GBC, 2-12
 - reference address, 4-12
- Series Six Reference, 4-5
- Share RAM fault, 5-5
- Short Circuit fault, 5-4
- Signal/noiseratio, 1-8
- Slot number, 3-4
- Specifications
 - Genius bus, 1-8
 - Genius Bus Controller, 1-6
- Status
 - of COMMREQ, 6-8–6-11
 - starting reference, 4-5, 4-11
- Status bits, 5-1
 - meaning, 2-3
 - memory for, 2-1
 - transferring to CPU, 2-7
- Status block
 - clearing, 6-8
 - COMMREQ, 6-9

- Status LEDs, 1-5
- Subfunction code, 6-12, 6-22
- Sweep time, 2-6
 - minimizing, 2-10
- Sweep, PLC, scan time contributions, 2-7
- Switch Fail fault, 5-4
- System design, 3-2–3-4

T

- Technical help, 5-6
- Terminal assembly
 - installation, 3-10
 - removal, 3-9
- Terminating the bus, 1-8, 3-8
- Timing
 - additional information, 6-21
 - bus scan and CPU sweep, 6-16, 6-20
 - bus scan time, 2-11
 - CPU sweep time, 2-7
 - device to device response time, 2-11
- Token passing, 1-11, 2-6

U

- User Scaling Error fault, 5-5

V

- Versions
 - CPU, 1-7
 - software, 1-7

W

- WD (watchdog) Timeout fault, 5-5
- Wiring Error fault, 5-4