

**IC693CMM311**

**New In Stock!**

**GE Fanuc**

<http://www.pdfsupply.com/automation/ge-fanuc/series-90-30/IC693CMM311>

**Series 90-30**

**1-919-535-3180**

**In Stock! IC693CMM Communications Card IC693C IC693CM  
IC693CMM**

[www.pdfsupply.com](http://www.pdfsupply.com)

**Email:** [sales@pdfsupply.com](mailto:sales@pdfsupply.com)

# Chapter 2

## *The Communications Coprocessor Modules*

---

---

This chapter describes the Communications Coprocessor modules (CMM311, CMM711) and explains how to install and configure the modules. Also included is a discussion of the system operation of the modules in the Series 90 PLC:

The chapter is divided into two sections.

- Section 1: Description of CMM Hardware and Operation
- Section 2: Installing and Configuring the CMM

### **Overview of the CMM**

The Communications Coprocessor Module (CMM) is a high-performance microcomputer designed to perform communications functions in a Series 90 PLC system.

The CMM is closely coupled to the Series 90 PLC and may be configured to behave as two independent communications ports. For many applications, each port behaves like an independent window into the PLC for access by other devices, such as industrial computers and color graphic terminals. Many applications, which accessed the Series Six PLC user reference tables using CCM or RTU protocols, can now support the Series 90 PLC with little or no change. Many applications, which access the Series 90 PLC via the built-in serial port on the PLC CPU using SNP protocol, can now access the PLC via the CMM module.

Each CMM occupies a single slot in a Series 90 PLC rack. Up to 28 CMMs may be installed in a single Series 90-70 PLC system to improve access to serial I/O devices and to access PLC memory. In Series 90-30 PLCs, up to 4 CMMs may be installed in the main rack (baseplate).

# Section 1: Description of CMM Hardware and Operation

This section covers the following topics for both the CMM711 for the Series 90-70 PLC and the CMM311 for the Series 90-30 PLC.

- LED Indicators
- Restart/Reset Pushbutton
- Serial Connectors
- System Operation

The figures below show the layout of the CMM modules:

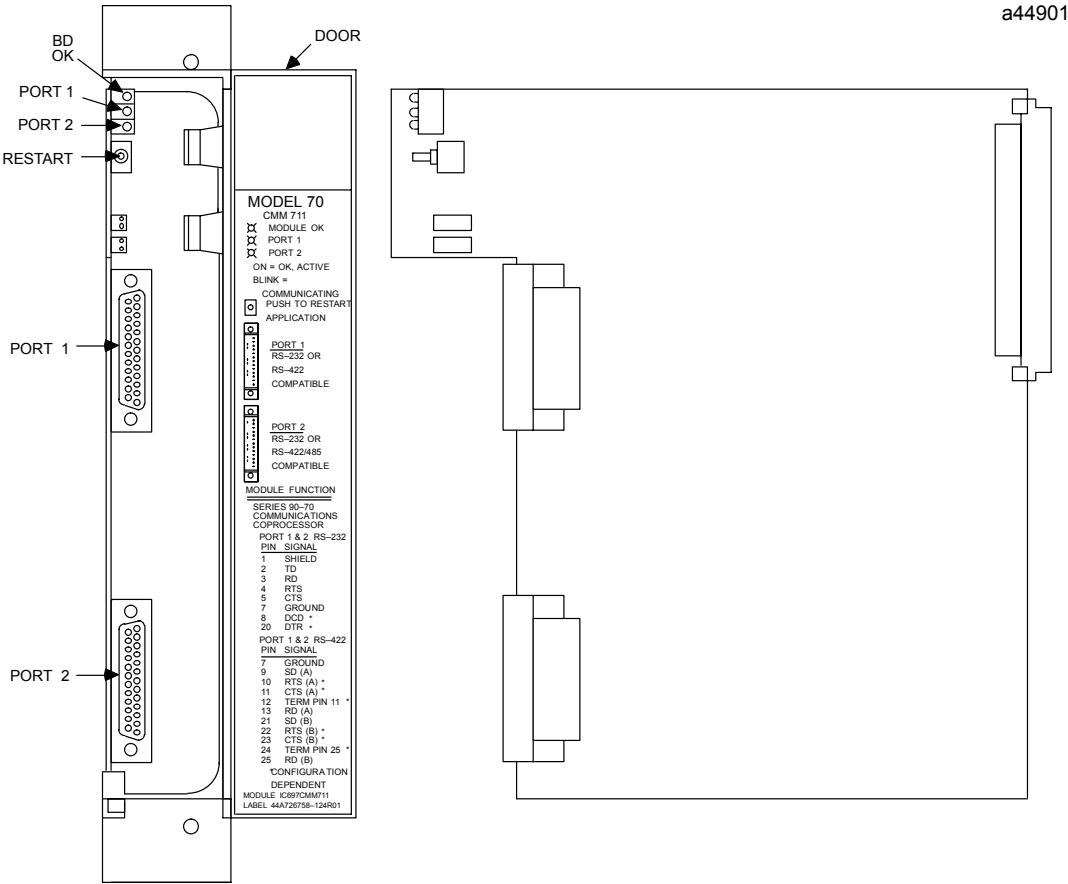
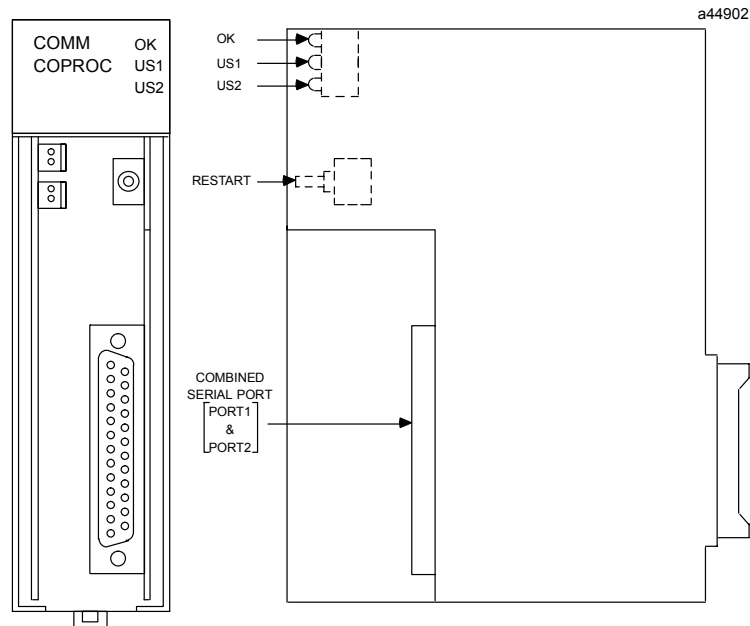


Figure 2-1. Series 90-70 CMM (CMM711)



**Figure 2-2. Series 90-30 CMM (CMM311)**

Except for the serial port connectors, the user interfaces for the CMM311 and CMM711 are the same. The Series 90-70 CMM711 has two serial port connectors. The Series 90-30 CMM311 has a single serial port connector supporting two ports. Each of the user interfaces are discussed below in detail.

## LED Indicators

The three LED indicators, as shown in the figures above, are located along the top front edge of the CMM board.

### Module OK LED

The MODULE OK LED indicates the current status of the CMM board. It has three states:

*Off:* When the LED is off, the CMM is not functioning. This is the result of a hardware malfunction (that is, the diagnostic checks detect a failure, the CMM fails, or the PLC is not present). Corrective action is required in order to get the CMM functioning again.

*On:* When the LED is steady on, the CMM is functioning properly. Normally, this LED should always be on, indicating that the diagnostic tests were successfully completed and the configuration data for the module is good.

*Flashing:* The LED flashes during power-up diagnostics.

### Serial Port LEDs

The remaining two LED indicators, PORT1 and PORT2 (US1 and US2 for the Series 90-30 CMM311) blink to indicate activity on the two serial ports. PORT1 (US1) blinks when port 1 either sends or receives data; PORT2 (US2) blinks when port 2 either sends or receives data.

## Restart/Reset Pushbutton

If the Restart/Reset pushbutton is pressed when the MODULE OK LED is on, the CMM will be re-initialized from the Soft Switch Data settings.

If the MODULE OK LED is off (hardware malfunction), the Restart/Reset pushbutton is inoperative; power must be cycled to the entire PLC for CMM operation to resume.

## Serial Ports

The serial ports on the CMM are used to communicate with external devices. The Series 90-70 CMM (CMM711) has two serial ports, with a connector for each port. The Series 90-30 CMM (CMM311) has two serial ports, but only one connector. The serial ports and connectors for each PLC are discussed below.

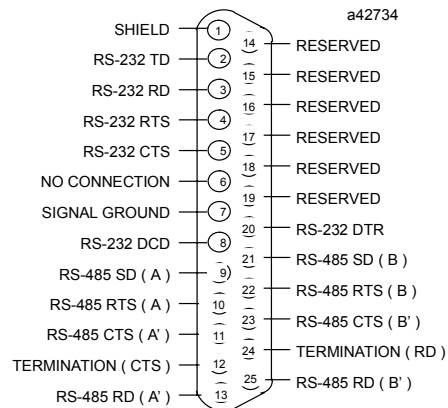
### Serial Ports for the CMM711

The Series 90-70 CMM has two serial ports, each of which support both RS-232 and RS-485 modes. The pin assignments of the serial ports are identical.

#### Note

When using the RS-485 mode, the CMM can be connected to RS-422 devices as well as RS-485 devices.

The connector pin assignments for both ports of the Series 90-70 CMM are shown below:



**Figure 2-3. Serial Port Pin Assignments for the Series 90-70 CMM**

#### Note

In the figure above, SD (Send Data) and RD (Receive Data) are the same as TXD and RXD (used in the Series Six™ PLC). (A) and (B) are the same as – and +. A' and B' denote inputs, and A and B denote outputs. To terminate the RS-485 CTS input signal, jumper pins 11 and 12; to terminate the RD input signal, jumper pins 24 and 25.

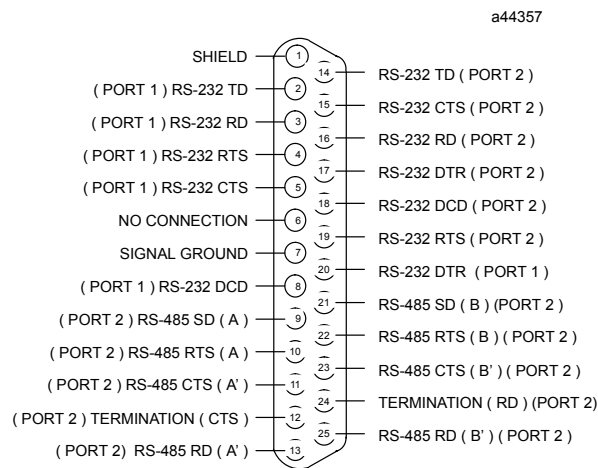
## Serial Ports for the IC693CMM311

The Series 90-30 CMM has a single serial connector which supports two ports. Port 1 applications must use the RS-232 interface. Port 2 applications can select either the RS-232 or RS-485 interface.

### NOTE

When using the RS-485 mode, the CMM can be connected to RS-422 devices as well as RS-485 devices.

The connector pin assignments for the Series 90-30 CMM are shown below.



**Figure 2-4. Serial Port Pin Assignments for the IC693CMM311**

The RS-485 signals for port 2 and the RS-232 signals for port 1 are assigned to the standard connector pins. The RS-232 signals for port 2 are assigned to normally unused connector pins.

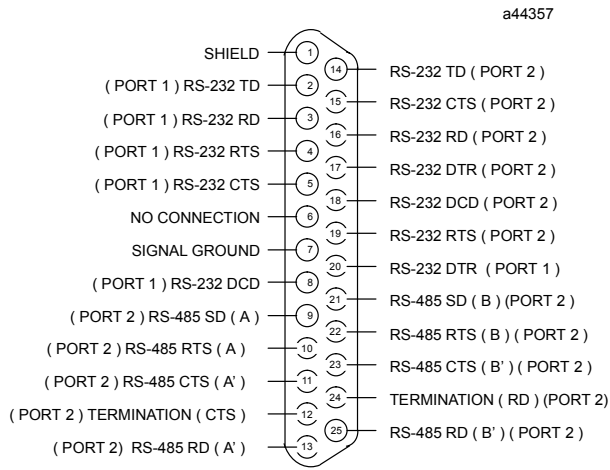
## IC693CBL305 Wye Cable

A Wye cable (IC693CBL305) is supplied with each Series 90-30 CMM and PCM module. The purpose of the Wye cable is to separate the two ports from a single physical connector (that is, the cable separates out the signals). In addition, the Wye cable makes cables used with the Series 90-70 CMM fully compatible with the Series 90-30 CMM and PCM modules.

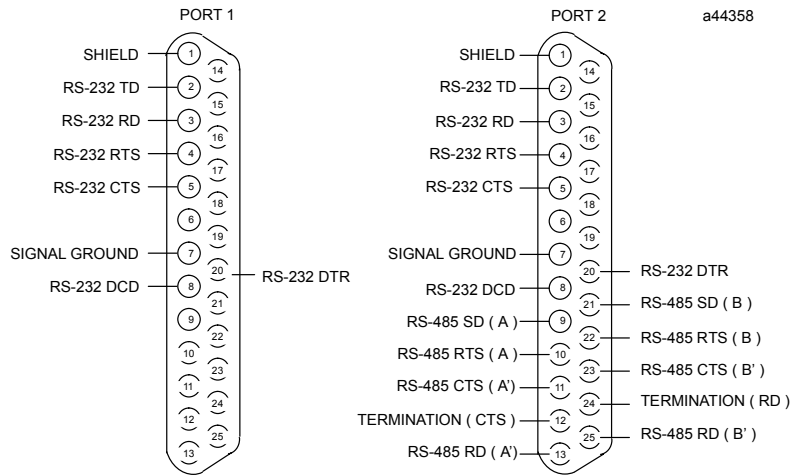
The IC693CBL305 Wye cable is 1 foot in length and has a right angle connector on the end that connects to the serial port on the CMM module. The other end of the cable has dual connectors; one connector is labeled **PORT 1**, the other connector is labeled **PORT 2** (see figure below).

The IC693CBL305 Wye cable routes the Port 2, RS-232 signals to the RS-232 designated pins. If you do not use the Wye cable, you will need to make a special cable to connect RS-232 devices to Port 2.

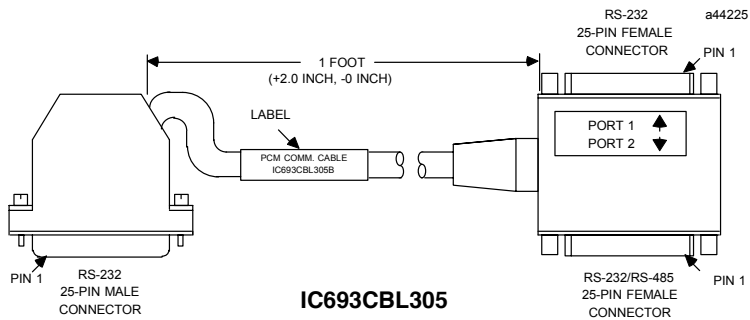
See the following figure for IC693CBL305 cable connection information.



**Single Connector End**



**Wye Connector End**



**Figure 2-5. IC693CBL305 Wye Cable Connections**

## *Section 2: Installing and Configuring the CMM*

This section explains how to install the CMM in the rack (Series 90-70) or baseplate (Series 90-30) and how to configure the module using Logicmaster 90 or the windows-based programming software. Topics covered are:

- What you will Need
- Installing the CMM
- Configuring the CMM

### **What you will Need**

Before you can begin the installation procedure, you must have the following equipment and software packages:

- A Series 90-70 or Series 90-30 Programmable Logic Controller (PLC).  
(For Series 90-30, the CPU must be a model CPU331 or higher.)
- A Communications Coprocessor Module (CMM) to install and test:
  - IC697CMM711 for a Series 90-70 CMM
  - IC693CMM311 for a Series 90-30 CMM

If this application uses CCM protocol with standard default settings for a Series 90-30 CMM (CMM 311), no other equipment is required.

For other applications, you will also need the following:

- A computer with a hard disk.
- Programming software (either Logicmaster 90 or windows-based programming software).

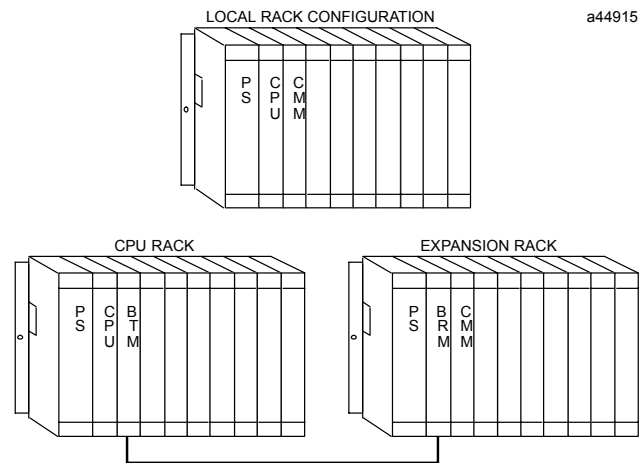
## Installing the CMM Hardware

The first step in the installation procedure is to physically install the CMM hardware and verify that it is working properly.

### Overview

In a single rack system, the CMM resides in the same rack as the CPU. In a Series 90-70 multiple rack system, the CMM can reside in either the CPU rack or in an expansion rack. The Series 90-30 CMM must reside in the same rack as the CPU.

The following illustration shows one possible system configuration for installing a Series 90-70 CMM in a local or expansion rack:



**Figure 2-6. Series 90-70 CMM Configurations**

The power supply, CPU, and Series 90-70 Bus Expansion Module must reside in specific slots within the rack. The term Bus Expansion Module includes both Bus Transmitter Modules and Bus Receiver Modules. The CPU Module must be located in slot 1 of rack 0.

The Series 90-70 system usually includes a Bus Transmitter Module (BTM). Version A of the Bus Transmitter Module must be located to the right of all other GE Fanuc boards; version B must be located in slot 2 of rack 0. If the PLC system will have more than one rack, a Bus Receiver Module (BRM) must be located in slot 1 of each expansion rack.

The CMM can be placed in any slot not already allocated in any rack, with the following cautions:

- The configuration files created by the Logicmaster 90 configuration software must match the physical configuration of the modules. If they do not, the controller may not operate as expected. Any faults will be logged in the PLC fault table.
- When CMMs are in a Series 90-70 rack, all the slots between the CMM and the PLC CPU must be occupied. If any of these slots are empty, the CMM will not be able to communicate across the backplane to the Series 90-70 PLC CPU.
- The Series 90-30 CMM must be in the main rack (baseplate) with the PLC CPU.

## Installing the CMM in the Rack

To install the CMM in the rack, follow these steps:

1. Set the PLC CPU to STOP. This will prevent the local PLC application program, if any, from initiating any command that may affect the operation of the module.
2. Power down the Series 90 PLC system.
3. Locate the desired rack and slot.
4. Slide the CMM completely into the slot. The three LEDs will be at the top of the board.
5. Press down firmly to lock the board in place, but do not use excessive force.
6. Power up the PLC rack. The top LED (MODULE OK) of the Series 90-70 CMM will flash during power-up diagnostics. It continues to flash while waiting for configuration data from the CPU. If no signal is received across the backplane for 30 seconds, the Series 90-70 CMM will assume the CPU is not there and continue to power up without it. Once the CMM is ready, this LED should stop flashing and remain ON.

### Note

The top LED (MODULE OK) of the Series 90-30 CMM will not light if the PLC is not present, or if the CMM fails its power-up diagnostics.

7. Repeat this procedure for each CMM.

## Troubleshooting

After completing the above steps to install the CMM, the MODULE OK (BD OK) LED should be on continuously. If it is not, the problem may be either that the LED is burned out, or the board has not passed diagnostics. Follow this procedure to determine the cause of the problem:

1. Make sure that power to the rack is on, the PLC is okay, and that the CMM is seated properly.
2. Check the PLC fault table using the programming software. If there is a *bad or missing module* fault, the board may be defective; otherwise, contact the GE Fanuc Technical Support Hotline for assistance. The GE Fanuc PLC Technical Support Hotline can be reached at 1-800-GE FANUC (1-800-433-2682), or International direct dial 804-978-6036.
3. Change the CMM config to *SNP* (RS-232 is needed), and run the programming software through the CMM using either the IC690CBL702 (9-pin AT) or IC690CBL705 (25-pin PS-2) cable.

## Configuring the CMM

Configuring the CMM through the programming software is a two-part procedure:

- I/O Rack Configuration
- Module Configuration (Soft Switch Data)

### I/O Rack Configuration

The Series 90 I/O Rack Configuration software is used to define the type and location of all modules present in the PLC racks. This is done by completing setup screens which represent the modules in a rack. Specific configuration settings for individual modules can then be selected. The configuration data is saved in a configuration file which is then stored to the Series 90 PLC.

#### Series 90-70 PLCs

A rack in the Series 90-70 PLC can be used as a main CPU rack or as an expansion rack. Racks are available that have either 5 or 9 slots for modules, plus provision for a power supply or power supply connection in the leftmost slot. The rack shown in the previous illustration has 9 slots for modules.

The rack in which the CPU resides requires a power supply in slot PS and a CPU module in slot 1. Slot 1 in the CPU rack is reserved for the CPU module; in an expansion rack, slot 1 is reserved for the Bus Receiver Module (BRM). A Bus Transmitter Module must be installed in slot 2 of rack 0 if it is a version B (or later) module; version A of the BTM must be located to the right of all other GE Fanuc boards. The BTM is required for parallel communications with the programmer, or if multiple racks are to be in a system.

The remaining slots can contain combinations of I/O or intelligent modules to suit the application program. The CMM can be installed in any slot, except for slot 1, in any rack in the system. There can be no empty slots to the left of option modules or I/O modules using interrupts (unless a Blank Slot Interrupt Jumper is installed in the empty slot) in a Series 90-70 PLC system. If more I/O is required in the system than can be contained in a single rack, additional racks can be added to the system, up to a maximum of eight racks (including the CPU rack).

#### Series 90-30 PLCs

For Series 90-30 PLCs, the CMM must reside in the CPU rack (baseplate). There is a slot for the power supply and slot 1 is reserved for the CPU module; the CMM can reside in any other slot. There are no Bus Expansion Modules as there are for the Series 90-70 PLCs.

### CMM Configuration Modes

The CMM configuration mode selects the communication protocol for each serial port on the module. There are nine possible configuration modes for the CMM module:

- CCM ONLY - CCM protocol on both ports
- CCM/RTU - CCM protocol on port 1, RTU protocol on port 2
- RTU/CCM - RTU protocol on port 1, CCM protocol on port 2

- RTU ONLY - RTU protocol on both ports
- SNP ONLY - SNP and SNP-X protocols on both ports
- SNP/CCM - SNP and SNP-X protocols on port 1, CCM protocol on port 2
- CCM/SNP - CCM protocol on port 1, SNP and SNP-X protocols on port 2
- SNP/RTU - SNP and SNP-X protocols on port 1, RTU protocol on port 2
- RTU/SNP - RTU protocol on port 1, SNP and SNP-X protocols on port 2

A different Soft Switch Data Screen is displayed for each configuration mode.

The factory default is CCM protocol on both ports. Make sure that the proper protocol is selected. If you are using SNP multidrop, make sure that the proper SNP ID has been stored to the PLC CPU. Note: If you change the CMM's SNP ID via the programming software, it is necessary to reset the CMM in order for the new SNP ID to take effect. Resetting the CMM can be done by either pressing the CMM's "Restart" pushbutton, or by power-cycling the PLC rack that contains the CMM.

## Description of Communications Parameters

The tables below describe the communications parameters available for each serial protocol on the CMM module:

**Table 2-1. CCM Communications Parameters**

Field	Range	Default
CCM Enable	YES, NO	YES
CCM Mode	SLAVE, MASTER, PEER	SLAVE
Interface <sup>1</sup>	RS232, RS485	RS232
Data Rate	300, 600, 1200, 2400, 4800, 9600, 19200	19200
Flow Control	NONE, HARDWARE	NONE
Parity	ODD, NONE	ODD
Retry Count	NORMAL, SHORT	NORMAL
Timeout	LONG, MEDIUM, SHORT, NONE	LONG
Modem Turnaround Delay	NONE, 10 ms, 100 ms, 500 ms	NONE
CCM CPU ID	1-254	1

**Table 2-2. RTU Communications Parameters**

Field	Range	Default
RTU Enable	YES, NO	YES
Interface <sup>1</sup>	RS232, RS485	RS232
Data Rate	300, 600, 1200, 2400, 4800, 9600, 19200	19200
Flow Control	NONE, HARDWARE	NONE
Parity	ODD, EVEN, NONE	ODD
Station Address	1 - 247	1

**Table 2-3. SNP Communications Parameters**

Field	Range	Default
SNP Enable	YES, NO	YES
SNP Mode	SLAVE, MASTER	SLAVE
Interface <sup>1</sup>	RS485, RS232	RS485
Data Rate	300, 600, 1200, 2400, 4800, 9600, 19200	19200
Flow Control	NONE, HARDWARE	NONE
Parity	ODD, EVEN, NONE	ODD
Stop Bits	1, 2	1
Timeout	LONG, MEDIUM, SHORT, NONE	LONG
Modem Turnaround Delay	NONE, 10 ms, 100 ms, 500 ms	NONE

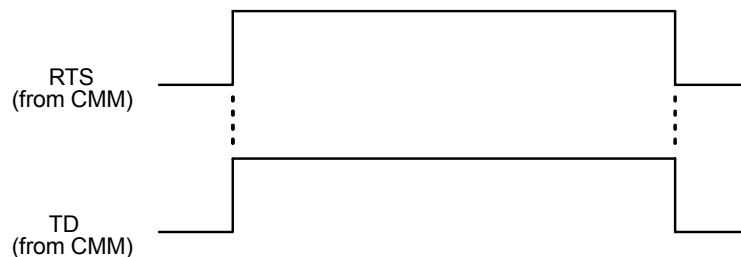
<sup>1</sup> For the CMM311 module, port 1 is RS-232 only.

### Notes on Communication Parameters

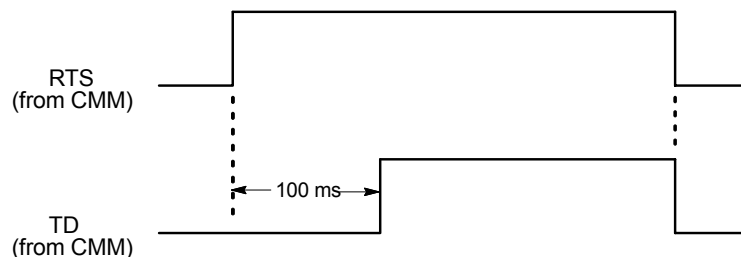
**Interface.** (CCM, RTU, and SNP) The *Interface* field specifies the type of electrical interface used at this serial port. Valid selections are RS-485 or RS-232. Note that for the CMM311 module, port 1 operates as RS-232 only.

**Flow Control.** (CCM, RTU, and SNP) The *Flow Control* field specifies the method of flow control to use at this serial port. Valid selections are NONE or HARDWARE. The timing diagrams below illustrate the state of the flow control lines for flow control = NONE and HARDWARE. **Note: The CMM modules do not support hardware flow control when used with an RS-485 interface.**

The NONE selection makes use of the signals Transmit Data (TD) and Receive Data (RD) only. The signal Request to Send (RTS), however, is used as a modem keying signal. The RTS signal is energized for the Modem Turnaround Delay interval and during the character transmission; the RTS signal is then immediately de-energized.

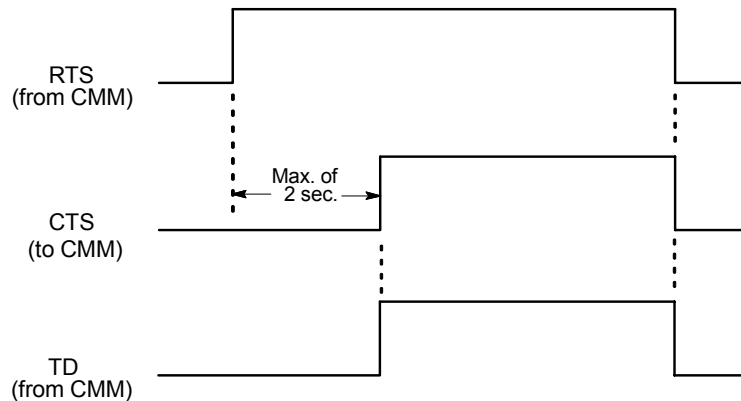


**Figure 2-7. Flow Control = NONE, MODEM TURNAROUND DELAY=0**



**Figure 2-8. Flow Control = NONE, MODEM TURNAROUND DELAY=100 ms**

The HARDWARE selection makes use of the Transmit Data (TD), Receive Data (RD), Request to Send (RTS, Clear to Send (CTS), Data Carrier Detect (DCD), and Data Terminal Ready (DTR). The signals are used in the manner specified by the RS-232 and RS-422/RS-485 electrical standards; these signals are described below:



**Figure 2-9. Flow Control = HARDWARE**

**Request to Send (RTS) and Clear to Send (CTS).** These signals are used to control the transmission of data to the remote device. The RTS signal is asserted at the beginning of each transmission by the CMM. The actual characters are not transmitted, however, until the CTS signal is returned. Once the characters are transmitted, the RTS signal is immediately removed. As in the case of NONE flow control, a nonzero Modem Turnaround Delay is NOT used to control the operation of the RTS signal. It is simply used to adjust the appropriate protocol timers for any delay in receiving the CTS signal once the RTS signal is asserted.

**Data Carrier Detect (DCD) and Data Terminal Ready (DTR).** These signals are used to control the reception of data from the remote device. The DCD signal, when received from the remote device, essentially forms a request to the CMM to prepare for reception of data. The CMM, in turn, asserts the DTR signal when it is prepared to receive the data. In the CMM, DTR is always asserted; it is never turned off.

**Timeout.** (CCM) The *Timeout* field displays the length of timeouts used for CCM on the target port. Valid selections are LONG, MEDIUM, SHORT, or NONE.

**Timeout.** (SNP) The *Timeout* field specifies a set of values for each of the SNP timers. Valid selections include LONG, MEDIUM, SHORT, or NONE. The SNP Timeout selections and the related timer values are specified in the following table. The timers in the second half of the table are derived from earlier timer values via the specified equation.

**Modem Turnaround Delay. (CCM and SNP Only)** The *Modem Turnaround Delay* field specifies the length of time required by the intervening modems to turn the link around. In the case that NONE flow control is selected, the Modem Turnaround Delay also specifies the length of time that the Request to Send (RTS) signal is asserted before any characters are transmitted. Valid selections are NONE, 10 ms, 100 ms, or 500 ms.

## Note

Timeout values used by Logictmaster 90 software and the Series 90-70 and 90-30 CPUs are also listed for comparison.

**Table 2-4. SNP Timer Values for Timeout Selections**

SNP Timer	None	Short	Medium	Long	LM90	90-30	90-70
T1	5 ms	5 ms	5 ms	5 ms	10 ms	5 ms	5 ms
T2	2 sec	500 ms	1 sec	2 sec	3 sec	1 sec	500 ms
T3'	Disabled	5 sec	10 sec	10 sec	10 sec	10 sec	10 sec
T4	50 ms	50 ms	50 ms	50 ms	100 ms	N/A	N/A
T5	Disabled	2 sec	5 sec	Disabled	10 sec	10 sec	10 sec
Transmission Delay <sup>1</sup>	0 sec	0 sec	0 sec	0 sec	0 sec	0 sec	0 sec
COMMREQ timeout <sup>2</sup>	30 sec	30 sec	30 sec	30 sec	N/A	N/A	N/A
T3	T3' - 80 character times						
T3''	T3 + 65 seconds						
T5'	T5 + 80 character times						
T5''	T5 + Transmission Delay + twice next message transmission time.						

<sup>1</sup> The *Transmission Delay* specifies the length of time required for the data to transfer from the initiating device to the responding device. This duration is also referred to as the *wire time*. Examples where this value may be changed to a non-zero value include instances where satellite links are used to transfer data.

<sup>2</sup> The *COMMREQ Timeout* specifies the maximum length of time that a COMMREQ can remain in process. If the COMMREQ command cannot be completed before this time interval, the COMMREQ processing is terminated, and an error code is returned in the COMMREQ Status Word indicating that a COMMREQ timeout has occurred.

See the "SNP Timers" section of Chapter 7, *Protocol Definition*, for a complete description of the SNP timers.