

IC693MDL240

New In Stock!

GE Fanuc

<http://www.pdfsupply.com/automation/ge-fanuc/series-90-30/IC693MDL240>

Series 90-30

1-919-535-3180

In Stock! 120 Volts ac Input IC693M IC693MD IC693MDL

www.pdfsupply.com

Email: sales@pdfsupply.com

IC693MDL240 Input Module Field Wiring Information

The following figure provides wiring information for connecting user supplied input devices and power source to the 120 volt AC input module.

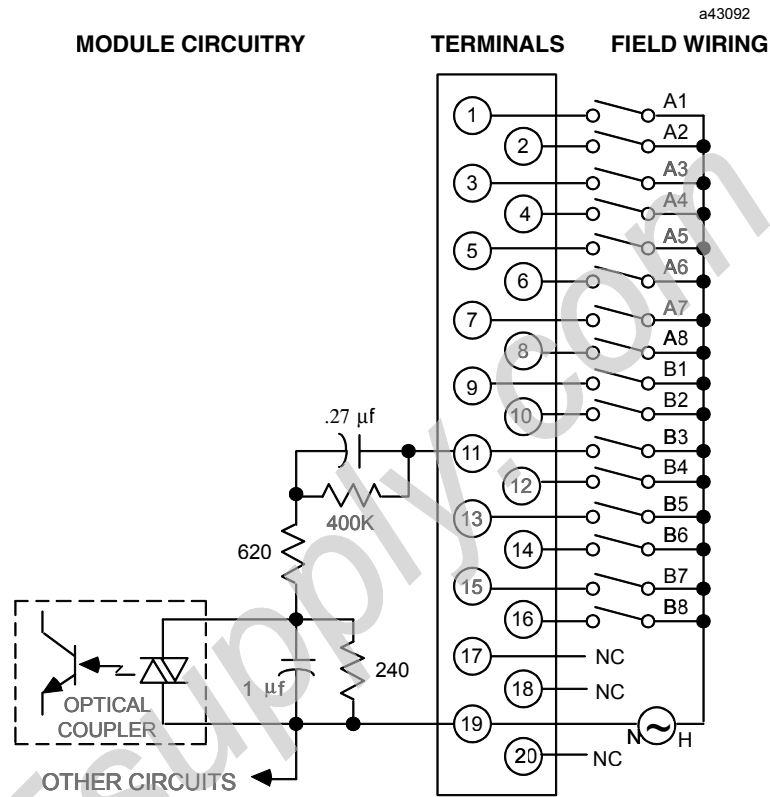

Figure 6-3. Field Wiring - 120 Volt AC Input Module - IC693MDL240

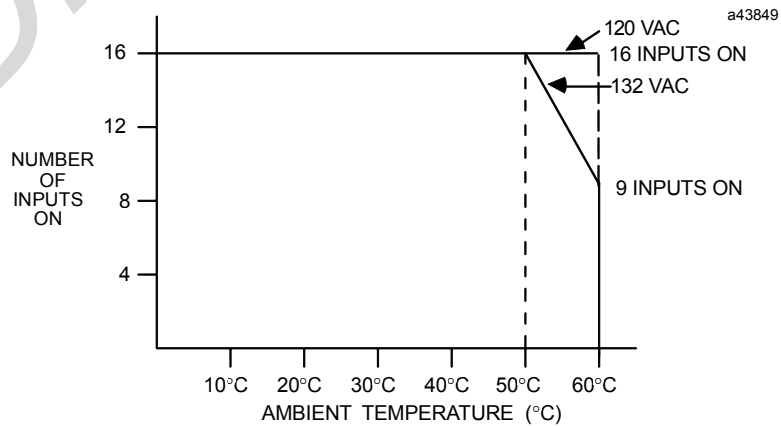

Figure 6-4. Input Points vs. Temperature for IC693MDL240