

IC693MDL250

New In Stock!

GE Fanuc

<http://www.pdfsupply.com/automation/ge-fanuc/series-90-30/IC693MDL250>

Series 90-30

1-919-535-3180

120 VAC ISOLATED 16 PT INPUT IC693M IC693MD IC693MDL

www.pdfsupply.com

Email: sales@pdfsupply.com

Series 90™-30

IC693MDL250

GFK-2366A
April 2009

120VAC 16-Point Isolated Input Module

The **120VAC 16-Point Isolated Input** module, IC693MDL250, provides 16 isolated input points. Input points can be used on different phases of the AC supply or powered from the same supply. An RC snubber protects each input against transient electrical noise on the power line.

The module's input filtering time can be changed during system operation by the application program.

This module can be used with a Box-style (IC694TBB032), Extended Box-style (IC694TBB132), Spring-style (IC694TBS032), or Extended Spring-style (IC694TBS132) Terminal Block. Extended terminal blocks provide the extra shroud depth typically needed for field wiring to AC devices. See the *PACSystems RX3i System Manual*, GFK-2314 revision B or later for more information about Terminal Blocks. Terminal Blocks are ordered separately.

Individually numbered LEDs show the ON/OFF status of each Input point. The TB LED is green when the module's removable terminal block is locked in place. It is red when the terminal block is not locked.

The red band on the door card shows that MDL250 is a high-voltage module.

This module can be installed in any I/O slot in a Series 90-30 or PACSystems RX3i system. It must be used with RX3i CPU release 3.50 or later. For compatible Series 90-30 CPUs, see "CPU Compatibility" on page 2.

Specifications: IC693MDL250

Rated Voltage	120VAC
Input Voltage Range	0 – 132VAC (47 to 63 Hz), 120VAC nominal
Inputs per Module	16 isolated
Isolation	
Field to Backplane	250 VAC continuous; 1500 VAC for 1 minute
Group to Group	250 VAC continuous; 1500 VAC for 1 minute
Input Current	7.0 mA per point (typical) at rated voltage
Input Filter Times	20 msec – 2540 msec in 20 msec increments. Sent from CPU. Enabled by DIP switch.
Power Consumption	220mA (with all inputs on) from 5 volt bus on backplane
Input Characteristics:	
On-state Voltage	70-132VAC
Off-state Voltage	0 to 20VAC
On-state Current	5mA minimum
Off-state Current	2.5mA maximum
On/Off Response Time	±0–1 AC cycles for filter times up to 840ms ±1–2 AC cycles for filter times of 840ms to 1600ms ±2–3 AC cycles for filter times of 1600ms to 1920ms ±3–4 AC cycles for filter times of 1920ms or more

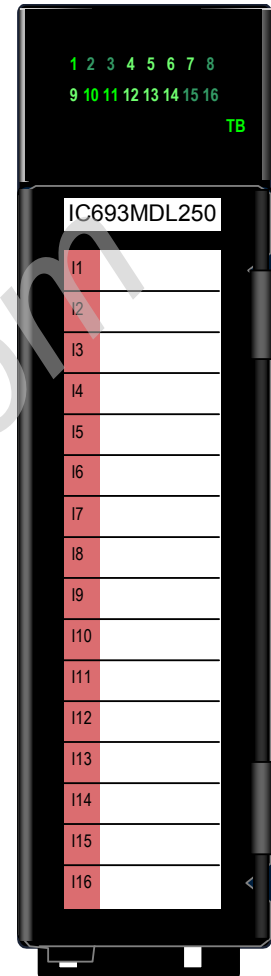

For product standards and general specifications, refer to Appendix A of the *PACSystems RX3i System Manual*, GFK-2314 or *GE Fanuc Product Agency Approvals, Standards, General Specifications*, GFK-0867 (Series 90-30 systems).

GFK-2366A

CPU Compatibility

Family	Model	Firmware Version
RX3i	All	3.5 and later
Series 90-30	CPU350	10.60 or later
	CPU352	10.50 or later
	CPU364	10.60 or later
	CPU374	11.03 or later

Release Information**Release History**

Version	Description
IC693MDL250-BA Firmware version: 1.10	Hardware update to correct a manufacturing issue.
IC693MDL250-AA Firmware version: 1.10	Initial release

Updates

No field upgrade is required or available for this hardware revision.

Enabling Input Filtering

The DIP switch pack on the back of the module can be used to enable or disable input filtering for all of the module’s inputs. The module must be removed from the backplane to set the switch.

- If switch 2 is disabled (OFF – the default setting), the CPU will not send Input Filtering settings to the module.
- If the CPU will send Input Filtering settings to the module, switch 2 must be set to Enabled (ON).

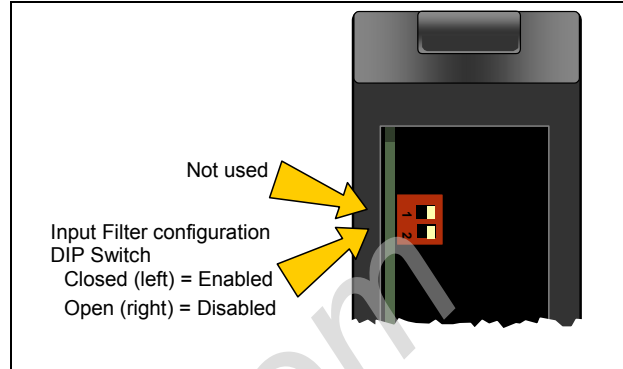

Configuring and Implementing Input Filtering

In addition to setting DIP switch 2 as described above, if an input filter time should be applied to all the module’s inputs, input filtering must be enabled in the module’s software configuration. This changes the Digital Filter Settings Length to 16. A memory location to be used for the filter value must be specified. If the software configuration does not match the DIP switch setting, a fault occurs.

During system operation, the input filter time can be changed from the programmer by entering a filter setting value from 1 to 127 decimal (1_{hex} to 7F_{hex}) into the assigned memory location. This filter setting value is equal to the new filter time divided by 20 decimal. For example, to change the filter time to 200ms, enter the value 10_{dec} (0A_{hex}) into the memory location. The filter setting value is sent in each scan of the module’s output data.

Some example filter times and their hexadecimal setting values are listed below.

Setting (hexadecimal)	Filter Time in milliseconds	Setting (hexadecimal)	Filter Time in milliseconds	Setting (hexadecimal)	Filter Time in milliseconds
0A	200	21	660	5A	1800
0F	300	22	680	5F	1900
11	340	2A	840	71	2260
12	360	2F	940	72	2280
1A	520	51	1620	7A	2240
1F	620	52	1660	7F	2540

GFK-2366A

Field Wiring: MDL250

Field wiring connections to the module are made to the removable terminal assembly, as described in the *RX3i System Manual*, GFK-2314 and the *Series 90-30 Installation Manual*, GFK-0356.

Connections	Terminals	Terminals	Connections
Input 1	1	19	Input 9
Input 1 Return	2	20	Input 9 Return
Input 2	3	21	Input 10
Input 2 Return	4	22	Input 10 Return
Input 3	5	23	Input 11
Input 3 Return	6	24	Input 11 Return
Input 4	7	25	Input 12
Input 4 Return	8	26	Input 12 Return
Input 5	9	27	Input 13
Input 5 Return	10	28	Input 13 Return
Input 6	11	29	Input 14
Input 6 Return	12	30	Input 14 Return
Input 7	13	31	Input 15
Input 7 Return	14	32	Input 15 Return
Input 8	15	33	Input 16
Input 8 Return	16	34	Input 16 Return
No connection	17	35	No connection
No connection	18	36	No connection

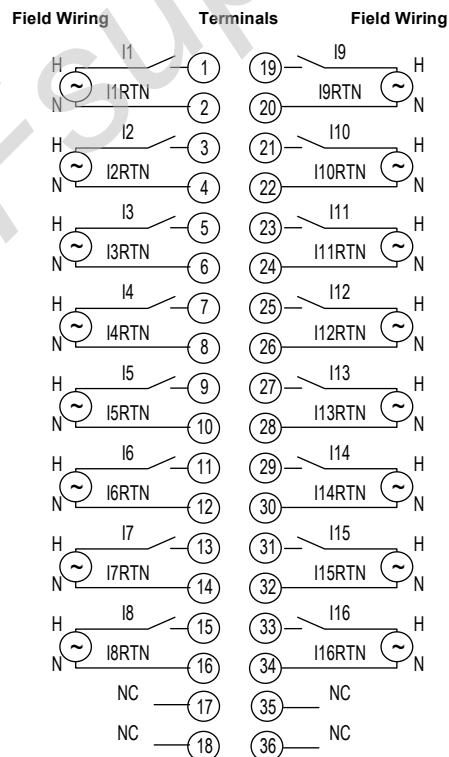

Installation in Hazardous Locations

- WARNING - EXPLOSION HAZARD - SUBSTITUTION OF COMPONENTS MAY IMPAIR SUITABILITY FOR CLASS I, DIVISION 2.
- WARNING - EXPLOSION HAZARD - WHEN IN HAZARDOUS LOCATIONS, TURN OFF POWER BEFORE REPLACING OR WIRING MODULES.
- WARNING - EXPLOSION HAZARD - DO NOT CONNECT OR DISCONNECT EQUIPMENT UNLESS POWER HAS BEEN SWITCHED OFF OR THE AREA IS KNOWN TO BE NONHAZARDOUS.
- EQUIPMENT LABELED WITH REFERENCE TO CLASS I, GROUPS A, B, C & D, DIV. 2 HAZARDOUS LOCATIONS IS SUITABLE FOR USE IN CLASS I, DIVISION 2, GROUPS A, B, C, D OR NON-HAZARDOUS LOCATIONS ONLY.

PDFsupply.com