

IC693MDL632

New In Stock!

GE Fanuc

<http://www.pdfsupply.com/automation/ge-fanuc/series-90-30/IC693MDL632>

Series 90-30

1-919-535-3180

125 Volts DC IC693M IC693MD IC693MDL

www.pdfsupply.com

Email: sales@pdfsupply.com

IC693MDL632 Input Module Field Wiring Information

The following figure provides wiring information for connecting user supplied input devices and power source to the 125 volt DC positive/negative logic input module. The negative logic connections are shown in dashed lines.

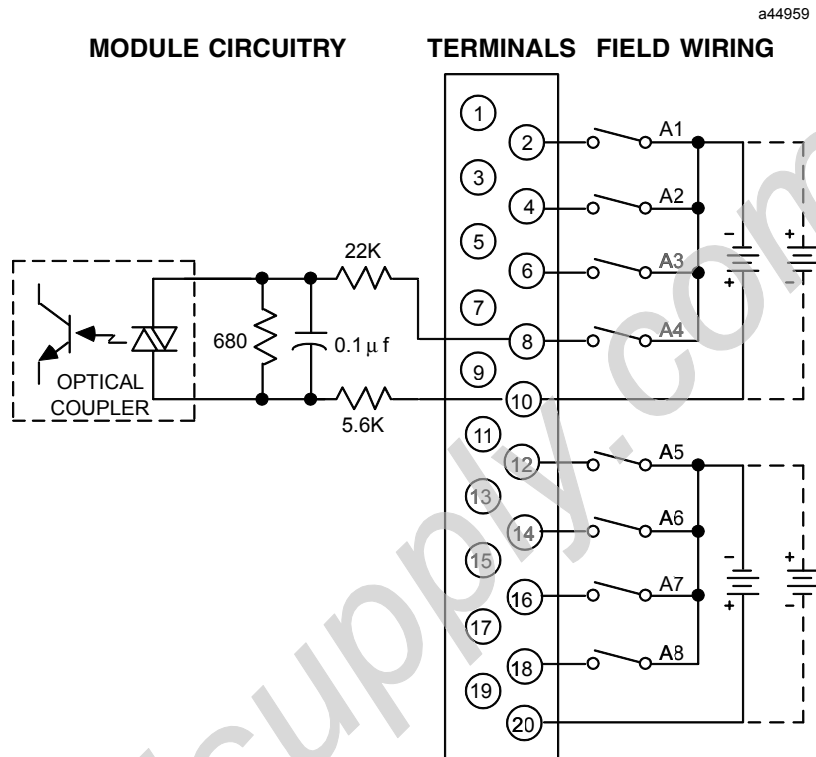

Figure 6-7. Field Wiring - 125 Volt DC Positive /Negative Logic Input Module - IC693MDL632

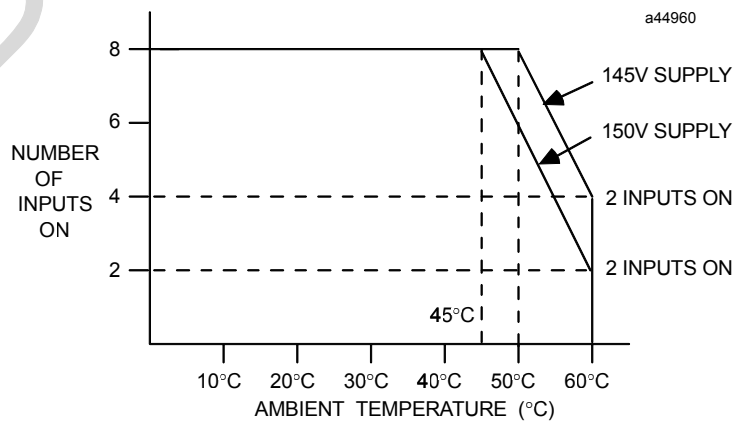

Figure 6-8. Input Points vs. Temperature for IC693MDL632