

**IC693MDL646**

**New In Stock!**

**GE Fanuc**

<http://www.pdfsupply.com/automation/ge-fanuc/series-90-30/IC693MDL646>

**Series 90-30**

**1-919-535-3180**

**In Stock! 24 Volts dc Input, Neg/Pos Logic IC693M IC693MD  
IC693MDL**

[www.pdfsupply.com](http://www.pdfsupply.com)

**Email:** [sales@pdfsupply.com](mailto:sales@pdfsupply.com)

## 24 Volt DC Positive/Negative Logic Input, 16 Point IC693MDL646

This **24 volt DC Positive/Negative Logic Input** module for the Series 90-30 Programmable Logic Controller provides 16 input points in one group with a common power input terminal. *The on and off response times for this module are typically 1 ms.* This input module is designed to have either positive logic or negative logic characteristics. Input characteristics are compatible with a wide range of user-supplied input devices, such as pushbuttons, limit switches, and electronic proximity switches. Current into an input point results in a logic 1 in the input status table (%I). Power to operate the field devices can be supplied by the user, or an Isolated +24 VDC supply on the power supply (+24V OUT and 0V OUT terminals) can power a limited number of inputs.

LED indicators which provide the ON/OFF status of each point are located at the top of the module. This LED block has two horizontal rows with eight green LEDs in each row; the top row labeled A1 through 8 (points 1 through 8) and the bottom row labeled B1 through 8 (points 9 through 16). An insert goes between the inside and outside surface of the hinged door. The surface towards the inside of the module (when the hinged door is closed) has circuit wiring information, and circuit identification information can be recorded on the outside surface. The outside left edge of the insert is color-coded blue to indicate a low-voltage module. This module can be installed in any I/O slot in a Series 90-30 PLC system.

**Table 6-8. Specifications for IC693MDL646**

<b>Rated Voltage</b>	24 volts DC
<b>Input Voltage Range</b>	0 to +30 volts DC
<b>Inputs per Module</b>	16 (one group with a single common)
<b>Isolation</b>	1500 volts between field side and logic side
<b>Input Current</b>	7 mA (typical) at rated voltage
<b>Input Characteristics</b>	
<b>On-state Voltage</b>	11.5 to 30 volts DC
<b>Off-state Voltage</b>	0 to +5 volts DC
<b>On-state Current</b>	3.2 mA minimum
<b>Off-state Current</b>	1.1 mA maximum
<b>On response Time</b>	1 ms typical
<b>Off response Time</b>	1 ms typical
<b>Power Consumption: 5V</b>	80 mA (all inputs on) from 5 volt bus on backplane
<b>Power Consumption: 24V</b>	125 mA from the Isolated 24 volt backplane bus or from user supplied power

Refer to Appendix B for product standards and general specifications.

### IC693MDL646 Input Module Field Wiring Information

The following figure provides wiring information for connecting user supplied input devices and power source to the 24 volt DC positive/negative logic input module.

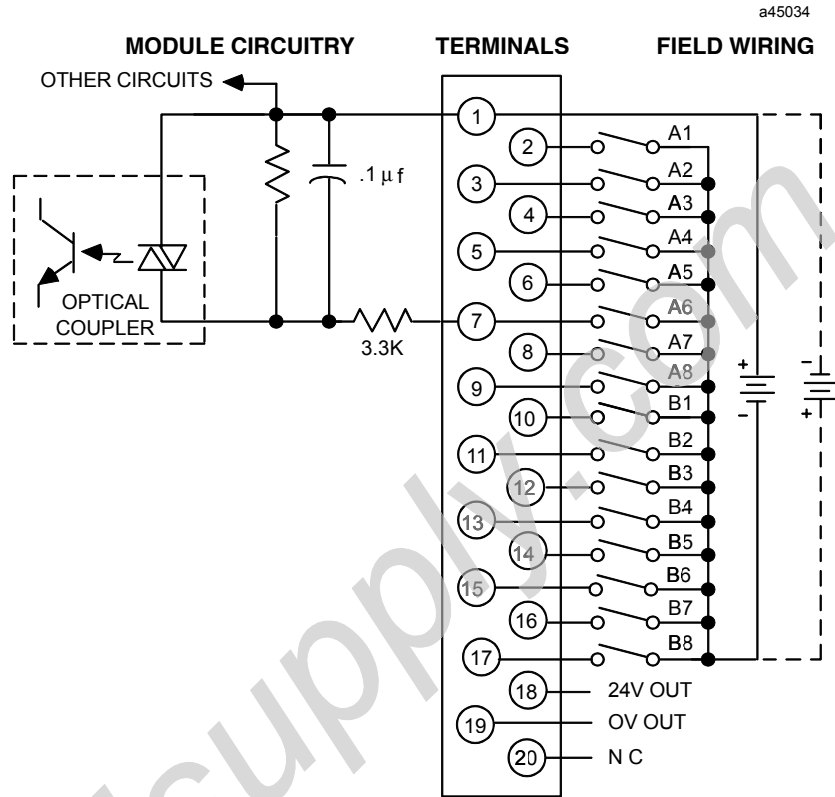

Figure 6-13. Field Wiring - 24 Volt DC Pos/Neg Logic Input Module - IC693MDL646

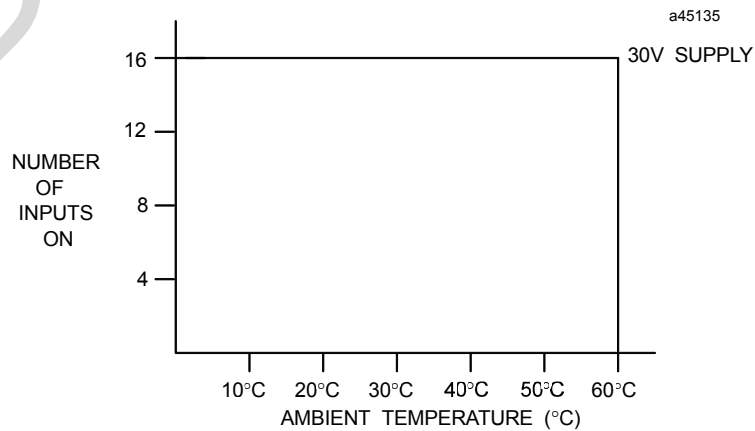

Figure 6-14. Input Points vs. Temperature for IC693MDL646