

**IC693MDL654**

**New In Stock!**

**GE Fanuc**

<http://www.pdfsupply.com/automation/ge-fanuc/series-90-30/IC693MDL654>

**Series 90-30**

**1-919-535-3180**

In Stock! 5/12 Volts dc (TTL) Input, Neg/Pos Logic IC693M  
IC693MD IC693MDL

[www.pdfsupply.com](http://www.pdfsupply.com)

**Email:** [sales@pdfsupply.com](mailto:sales@pdfsupply.com)

**Table 6-11. Specifications for IC693MDL654**

<b>Rated Voltage</b>	5 to 12 volts DC, Positive or Negative Logic
<b>Input Voltage Range</b>	0 to 15 volts DC
<b>Inputs per Module †</b>	32 (four groups of eight inputs each) <i>98.4 feet (30 meters) , maximum cable length</i>
<b>Isolation</b>	1500 volts between field side and logic side 250 volts between groups
<b>Input Current</b>	3.0 mA (typical ON current @ 5 VDC) 8.5 mA (typical ON current @ 12 VDC)
<b>Input Characteristics</b>	
<b>On-state Voltage</b>	4.2 to 15 volts DC
<b>Off-state Voltage</b>	0 to 2.6 volts DC
<b>On-state Current</b>	2.5 mA (minimum)
<b>Off-state Current</b>	1.2 mA (maximum)
<b>On response Time</b>	1 ms maximum
<b>Off response Time</b>	1 ms maximum
<b>Internal Power Consumption</b>	195 mA (maximum) from +5V bus on backplane; (29 mA + 0.5 mA/point ON + 4.7 mA/LED ON) 440 mA (maximum) from +5V bus on backplane <i>(if module isolated +5V supply used to power inputs and all 32 inputs ON)</i> 96 mA (typical) from user input supply @ 5 VDC and all 32 inputs ON 272 mA (typical) from user input supply @ 12 VDC and all 32 inputs ON
<b>Isolated +5V Supply Current limit</b>	+5 volts DC ±5% 150 mA (typical)

† Maximum number of inputs ON is dependent on ambient temperature as shown in the figure below.  
Refer to data sheet GFK-0867C, or later revision for product standards and general specifications.

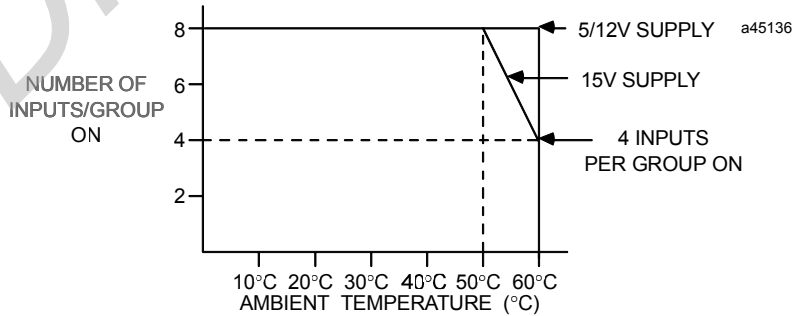

**Figure 6-17. Input Points vs. Temperature for IC693MDL654**

### IC693MDL654 Input Module Field Wiring Information

The following figures provide wiring information for connecting user supplied input devices and power source to the 5/12 volt DC (TTL) pos/neg logic input module.

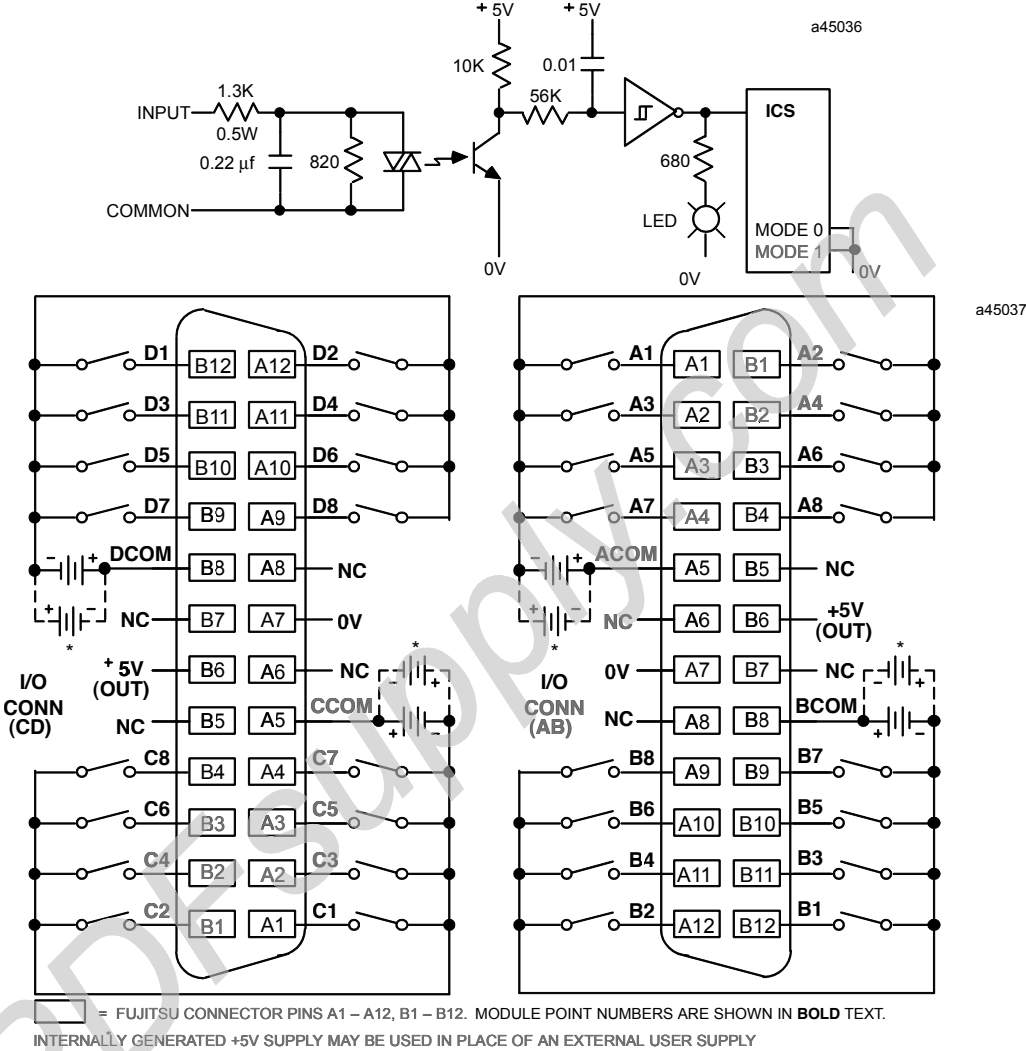

Figure 6-18. Field Wiring 5/12 Volt DC (TTL) Pos/Neg Logic 32-Point Input Module - IC693MDL654

## Field Wiring Work Sheet for IC693MDL654

The following table is provided for the convenience of our customers as an aid to wiring 32-point I/O modules that have 24-pin connectors using cable IC693CBL315. It includes all of the required wiring information in one table. This table has the following information:

- *module point number:* A1 - A8, B1 - B8, C1 - C8, D1 - D8, voltage and common points
- *connector pin number:* A1 through A12, and B1 through B12
- *cable pair number:* pair 1 through pair 12
- *wire color code:* base color or base color with tracer color

Columns are also provided for circuit references and customer wire numbers. Please copy and use the work sheets on this and the following page as needed when wiring the 5/12 VDC (TTL) Positive/Negative Logic, 32 Point Input module.

### Wiring for Module Groups A and B (connector on right front of module)

Reference	Module Point Number	Connector Pin Number	Cable Pair Number	Wire Color Code	Wire Number
	A1	A1	1	Brown	
	A2	B1	7	Violet	
	A3	A2	1	Brown/Black	
	A4	B2	7	Violet/Black	
	A5	A3	2	Red	
	A6	B3	8	White	
	A7	A4	2	Red/Black	
	A8	B4	8	White/Black	
	<b>A Common</b>	A5	3	Orange	
	N/C	B5	9	Gray	
	N/C	A6	3	Orange/Black	
	<b>+5V OUT</b>	B6	9	Gray/Black	
	<b>0 VOLTS</b>	A7	4	Yellow	
	N/C	B7	10	Pink	
	N/C	A8	4	Yellow/Black	
	<b>B Common</b>	B8	10	Pink/Black	
	<b>B8</b>	A9	5	Dark Green	
	<b>B7</b>	B9	11	Light Blue	
	<b>B6</b>	A10	5	Dark Green/Black	
	<b>B5</b>	B10	11	Light Blue/Black	
	<b>B4</b>	A11	6	Dark Blue	
	<b>B3</b>	B11	12	Light Green	
	<b>B2</b>	A12	6	Dark Blue/Black	
	<b>B1</b>	B12	12	Light Green/Black	

## Wiring for Module Groups C and D (connector on left front of module)

Reference	Module Point Number	Connector Pin Number	Cable Pair Number	Wire Color Code	Wire Number
	C1	A1	1	Brown	
	C2	B1	7	Violet	
	C3	A2	1	Brown/Black	
	C4	B2	7	Violet/Black	
	C5	A3	2	Red	
	C6	B3	8	White	
	C7	A4	2	Red/Black	
	C8	B4	8	White/Black	
	<b>C Common</b>	A5	3	Orange	
	N/C	B5	9	Gray	
	N/C	A6	3	Orange/Black	
	<b>+5V OUT</b>	B6	9	Gray/Black	
	<b>0 VOLTS</b>	A7	4	Yellow	
	N/C	B7	10	Pink	
	N/C	A8	4	Yellow/Black	
	<b>D Common</b>	B8	10	Pink/Black	
	<b>D8</b>	A9	5	Dark Green	
	<b>D7</b>	B9	11	Light Blue	
	<b>D6</b>	A10	5	Dark Green/Black	
	<b>D5</b>	B10	11	Light Blue/Black	
	<b>D4</b>	A11	6	Dark Blue	
	<b>D3</b>	B11	12	Light Green	
	<b>D2</b>	A12	6	Dark Blue/Black	
	<b>D1</b>	B12	12	Light Green/Black	