

IC693MDL733

New In Stock!

GE Fanuc

<http://www.pdfsupply.com/automation/ge-fanuc/series-90-30/IC693MDL733>

Series 90-30

1-919-535-3180

In Stock! 12/24 Volts dc Output, 0.5 Amp, Negative Logic (8)

IC693M IC693MD IC693MDL

www.pdfsupply.com

Email: sales@pdfsupply.com

12/24 Volt DC Negative Logic 0.5 Amp Output - 8 Point IC693MDL733

The *12/24 volt DC Negative Logic 0.5 Amp Output* module for the Series 90-30 Programmable Logic Controller provides 8 output points in one group with a common power output terminal. This output module is designed to have negative logic characteristics in that it sinks current from the loads to the user common or negative power bus. The output device is connected between the positive power bus and the module output. The output characteristics are compatible with a wide range of user-supplied load devices, such as: motor starters, solenoids, and indicators. Power to operate the field devices must be supplied by the user.

LED indicators which provide the ON/OFF status of each point are located at the top of the module. This LED block has two horizontal rows with eight green LEDs in each row; the top row labeled A1 through 8 (points 1 through 8) is used by this module. An insert goes between the inside and outside surface of the hinged door. The surface towards the inside of the module (when the hinged door is closed) has circuit wiring information, and circuit identification information can be recorded on the outside surface. The outside left edge of the insert is color-coded blue to indicate a low-voltage module. There are no fuses on this module.

This module can be installed in any I/O slot of a 5 or 10-slot baseplate in a Series 90-30 PLC system.

Table 7-10. Specifications for IC693MDL733

Rated Voltage	12/24 volts DC
Output Voltage Range	12 to 24 volts DC (+20%, -15%)
Outputs per Module	8 (one group)
Isolation	1500 volts between field side and logic side
Output Current	0.5 amps maximum per point 2 amps maximum per common
Output Characteristics	
Output Voltage Drop	0.5 volts maximum
Off-state Leakage	1 mA maximum
On Response Time	2 ms maximum
Off Response Time	2 ms maximum
Power Consumption	50 mA (all outputs on) from 5 volt bus on backplane

Refer to Appendix B for product standards and general specifications.

IC693MDL733 Output Module Field Wiring Information

The following figure provides wiring information for connecting user supplied load devices and power source to the 8 point 12/24 volt DC negative logic 0.5 amp output module.

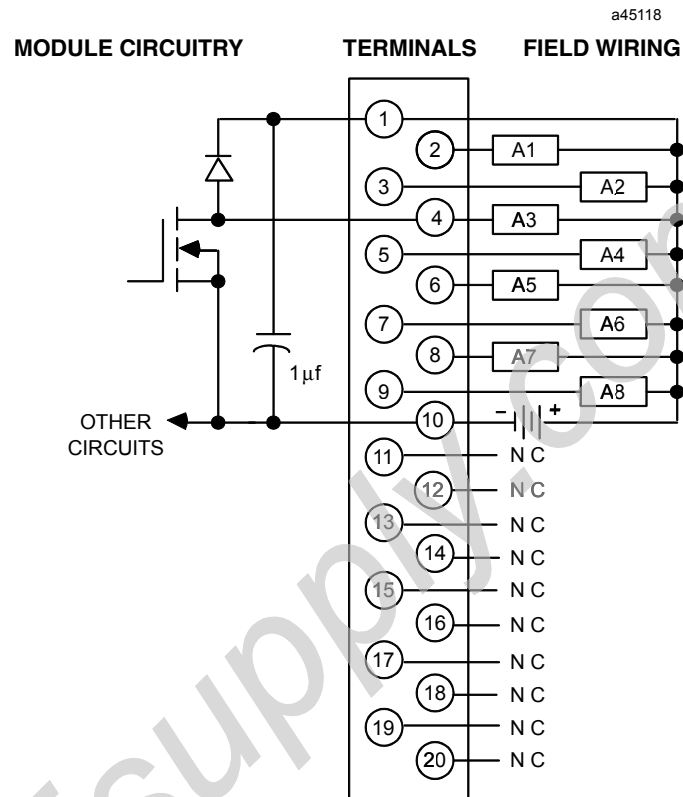

Figure 7-18. IC693MDL733 Output Module Field Wiring

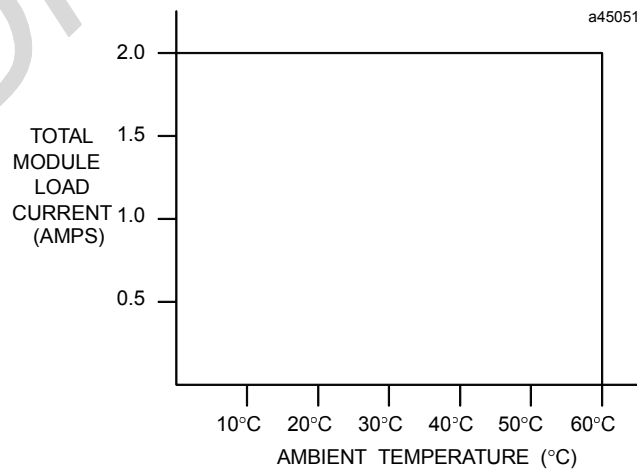

Figure 7-19. Load Current vs. Temperature for IC693MDL733