

IC693MDL753

New In Stock!

GE Fanuc

<http://www.pdfsupply.com/automation/ge-fanuc/series-90-30/IC693MDL753>

Series 90-30

1-919-535-3180

In Stock! IC693MDL 12/24 Volts dc Output, Pos Logic (32) IC693M
IC693MD IC693MDL

www.pdfsupply.com

Email: sales@pdfsupply.com

Table 7-24. Specifications for IC693MDL753

Rated Voltage	12 through 24 volts DC, positive logic
Output Voltage Range	10.2 to 28.8 volts DC
Outputs per Module	32 (four groups of eight outputs each)
Isolation	1500 volts between field side and logic side 250 volts between groups
Output Current	0.5 amps per point with 4 amps maximum per group and 3 amps maximum per group common pin
Output Characteristics	
Inrush Current	5.4 amps for 10 ms
On-state Voltage Drop	0.3 volts DC
Off-state Leakage Current	0.1 mA maximum
On Response Time	0.5 ms maximum
Off Response Time	0.5 ms maximum
Internal Power Consumption	260 mA (maximum) from 5 volt bus on backplane; (13 mA + 3 mA/point ON + 4.7 mA/LED) 16.5 mA (maximum) per group from user supply @ 24 VDC and all eight outputs in group ON 9.6 mA (maximum) per group from user supply @ 12 VDC and all eight outputs in group ON

Refer to data sheet GFK-0867C, or later revision for product standards and general specifications.

TYPICAL CIRCUIT

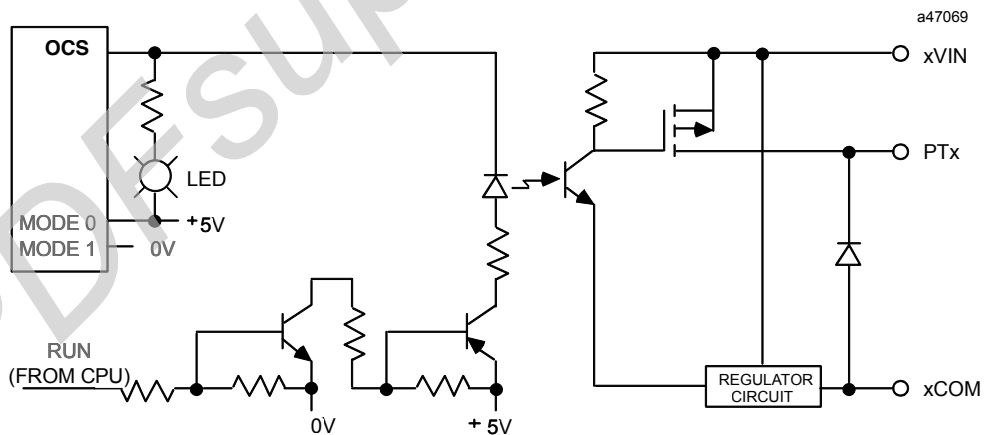

IC693MDL753 Output Module Field Wiring Information

The following figure provides wiring information for connecting user supplied load devices and power source to the 12/24 volt DC, 0.5A positive logic output module.

Module point numbers are shown in **bold text**.

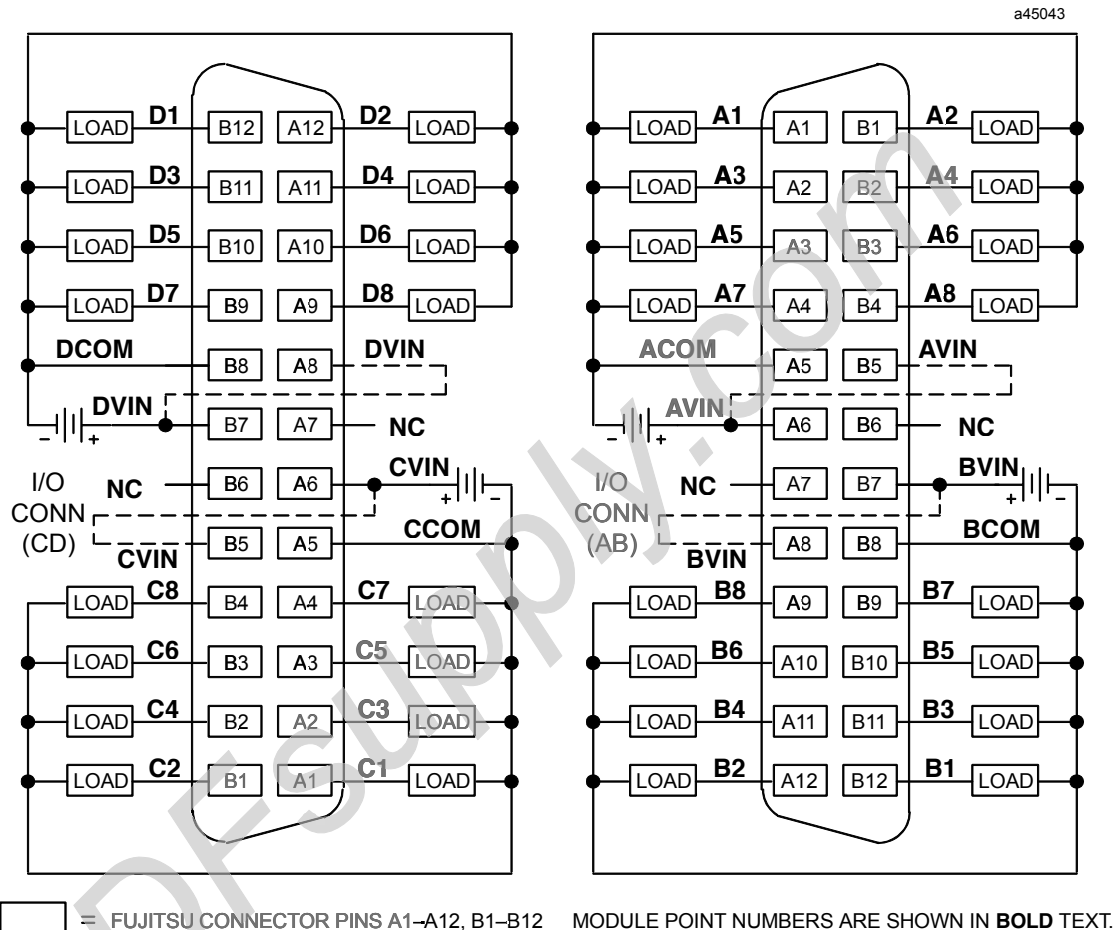

Figure 7-41. Field Wiring - 12/24 Volt DC, 0.5A Positive Logic 32 Point Output Module - IC693MDL753

Field Wiring Work Sheet for IC693MDL753

The following table is provided for the convenience of our customers as an aid to wiring the 24-pin connectors using cable IC693CBL315. It includes all of the required wiring information in one table. This table has the following information:

- *module point number:* A1 - A8, B1 - B8, C1 - C8, D1 - D8, voltage and common points
- *connector pin number:* A1 through A12, and B1 through B12
- *cable pair number:* pair 1 through pair 12
- *wire color code:* base color or base color with tracer color

Columns are also provided for circuit references and customer wire numbers. Please copy and use the work sheets on this and the following page as needed when wiring the 12/24 Volt DC, 0.5A Positive Logic, 32 Point Output module.

Wiring for Module Groups A and B (connector on right front of module)

Reference	Module Point Number	Connector Pin Number	Cable Pair Number	Wire Color Code	Wire Number
	A1	A1	1	Brown	
	A2	B1	7	Violet	
	A3	A2	1	Brown/Black	
	A4	B2	7	Violet/Black	
	A5	A3	2	Red	
	A6	B3	8	White	
	A7	A4	2	Red/Black	
	A8	B4	8	White/Black	
	A Common	A5	3	Orange	
	AVIN	B5	9	Gray	
	AVIN	A6	3	Orange/Black	
	N/C	B6	9	Gray/Black	
	N/C	A7	4	Yellow	
	BVIN	B7	10	Pink	
	BVIN	A8	4	Yellow/Black	
	B Common	B8	10	Pink/Black	
	B8	A9	5	Dark Green	
	B7	B9	11	Light Blue	
	B6	A10	5	Dark Green/Black	
	B5	B10	11	Light Blue/Black	
	B4	A11	6	Dark Blue	
	B3	B11	12	Light Green	
	B2	A12	6	Dark Blue/Black	
	B1	B12	12	Light Green/Black	

Wiring for Module Groups C and D (connector on left front of module)

Reference	Module Point Number	Connector Pin Number	Cable Pair Number	Wire Color Code	Wire Number
	C1	A1	1	Brown	
	C2	B1	7	Violet	
	C3	A2	1	Brown/Black	
	C4	B2	7	Violet/Black	
	C5	A3	2	Red	
	C6	B3	8	White	
	C7	A4	2	Red/Black	
	C8	B4	8	White/Black	
	C Common	A5	3	Orange	
	CVIN	B5	9	Gray	
	CVIN	A6	3	Orange/Black	
	N/C	B6	9	Gray/Black	
	N/C	A7	4	Yellow	
	DVIN	B7	10	Pink	
	DVIN	A8	4	Yellow/Black	
	D Common	B8	10	Pink/Black	
	D8	A9	5	Dark Green	
	D7	B9	11	Light Blue	
	D6	A10	5	Dark Green/Black	
	D5	B10	11	Light Blue/Black	
	D4	A11	6	Dark Blue	
	D3	B11	12	Light Green	
	D2	A12	6	Dark Blue/Black	
	D1	B12	12	Light Green/Black	