

IC693MDR390

New In Stock!

GE Fanuc

<http://www.pdfsupply.com/automation/ge-fanuc/series-90-30/IC693MDR390>

Series 90-30

1-919-535-3180

In Stock! IC693MDR 24Vdc Input Relay Output 8pt IC693M
IC693MD IC693MDR

www.pdfsupply.com

Email: sales@pdfsupply.com

Table 8-3. Specifications for IC693MDR390

Inputs	
Rated Voltage	24 volts DC
Input Voltage range	-30 to +32 volts DC
Inputs per Module	8 (one group of eight inputs)
Isolation	1500 volts RMS between field and logic side 500 volts RMS between inputs
Input Current	7.5 mA (typical) at rated voltage
Input Characteristics	
On-State Voltage	15 to 32 volts DC
Off-State Voltage	0 to +5 volts DC
On-State Current	4 mA (minimum)
Off-State Current	1.5 mA (maximum)
On Response Time	7 ms typical
Off Response Time	7 ms typical
Outputs	
Rated Voltage	24 VDC, 120/240 VAC
Operating Voltage	5 to 30 volts DC 5 to 250 volts AC, 50/60 Hz
Outputs per Module	8 (two groups of four outputs each)
Isolation	1500 volts RMS between field and logic side 500 volts RMS between groups
Maximum Load †	2 amps maximum per output 4 amps maximum per common
Minimum Load	10 mA
Maximum Inrush	5 amps
On Response Time	15 ms maximum
Off Response Time	15 ms maximum
Internal Power Consumption	80 mA (all I/O on) from +5V backplane bus 70 mA (all outputs on) from relay +24V backplane bus

† Maximum load current is dependent on operating voltage as shown in the following table.

Refer to Appendix B for product standards and general specifications.

Table 8-4. Load Current Limitations for IC693MDR390

Operating Voltage	Maximum Current for Load Type		Typical Operations (number of Operations)
	Resistive	Lamp or Solenoid †	
240 VAC, 120 VAC, 24 VDC	2 amps	.6 amps	200,000
240 VAC, 120 VAC, 24 VDC	1 amp	.3 amps	400,000
240 VAC, 120 VAC, 24 VDC	.5 amps	.1 amp	800,000

† For inductive loads

Relay contact life, when switching inductive loads, will approach resistive load contact life if suppression circuits are used. The following figures are examples of typical suppression circuits for AC and DC loads. The 1A, 100V diode shown in the DC load typical suppression circuit is an industry standard 1N4934. The resistor and capacitor shown for AC load suppression are standard components, available from most electronics distributors.

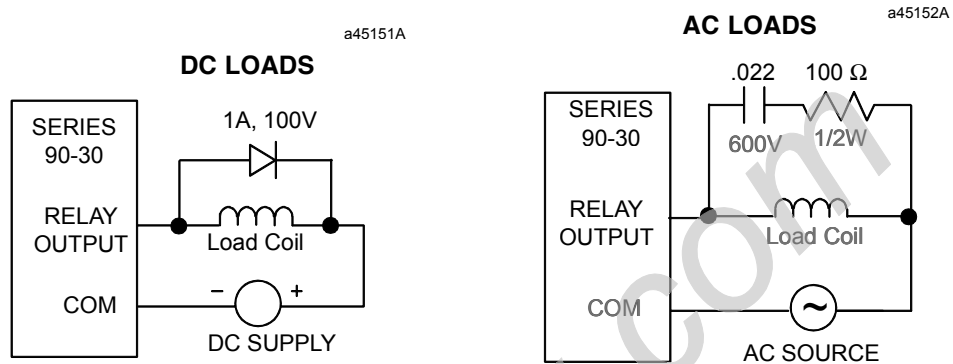

Field Wiring Information

The following figure provides wiring information for connecting user supplied input and load devices, and power source(s) to the 24 Volt Input/Relay Output module.

a45044

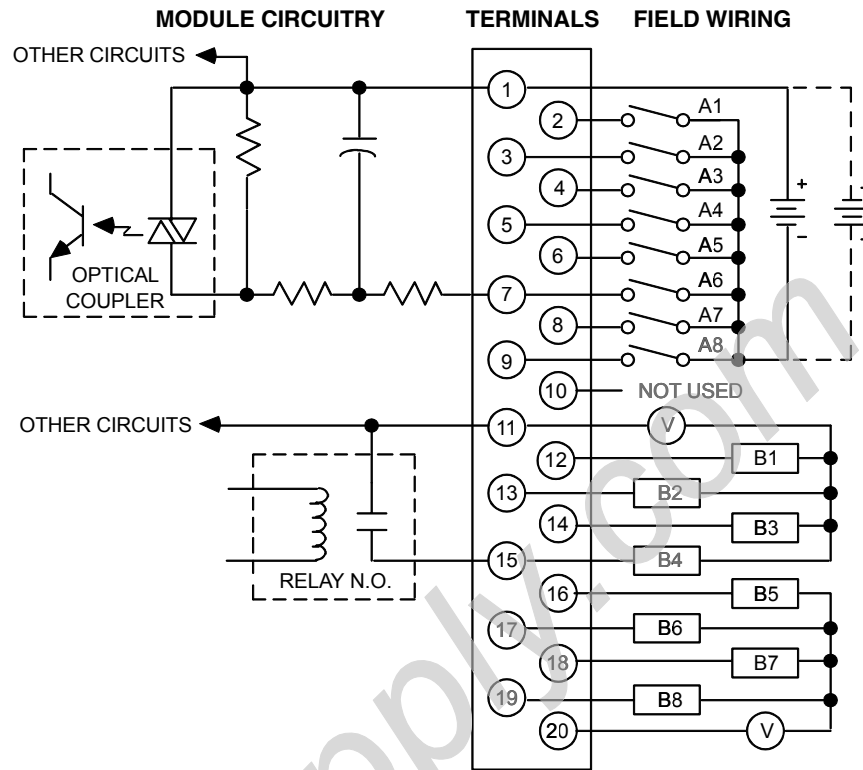

Figure 8-2. Field Wiring 24 VDC Input/Relay Output Module - IC693MDR390