

IC693PRG300

New In Stock!

GE Fanuc

<http://www.pdfsupply.com/automation/ge-fanuc/series-90-30/IC693PRG300>

Series 90-30

1-919-535-3180

In Stock! IC693PRG 90-30 Hand Held Programmer IC693P
IC693PG IC693PGR

www.pdfsupply.com

Email: sales@pdfsupply.com

Warnings, Cautions, and Notes as Used in this Publication

Warning

Warning notices are used in this publication to emphasize that hazardous voltages, currents, temperatures, or other conditions that could cause personal injury exist in this equipment or may be associated with its use.

In situations where inattention could cause either personal injury or damage to equipment, a Warning notice is used.

Caution

Caution notices are used where equipment might be damaged if care is not taken.

Note

Notes merely call attention to information that is especially significant to understanding and operating the equipment.

This document is based on information available at the time of its publication. While efforts have been made to be accurate, the information contained herein does not purport to cover all details or variations in hardware or software, nor to provide for every possible contingency in connection with installation, operation, or maintenance. Features may be described herein which are not present in all hardware and software systems. GE Fanuc Automation assumes no obligation of notice to holders of this document with respect to changes subsequently made.

GE Fanuc Automation makes no representation or warranty, expressed, implied, or statutory with respect to, and assumes no responsibility for the accuracy, completeness, sufficiency, or usefulness of the information contained herein. No warranties of merchantability or fitness for purpose shall apply.

The following are trademarks of GE Fanuc Automation North America, Inc.

Alam Master	CIMSTAR	Helpmate	PROMACRO	Series Six
CIMPLICITY	GENet	Logicmaster	Series One	Series 90
CIMPLICITY 90-ADS	Genius	Modelmaster	Series Three	VuMaster
CIMPLICITY PowerTRAC	Genius PowerTRAC	ProLoop	Series Five	Workmaster

Chapter 1

Introduction to the Hand-Held Programmer

The major features of the Hand-Held Programmer (catalog number IC693PRG300) for the Series 90-30, 90-20 and Micro Programmable Logic Controllers include:

- Creating a Statement List program, including insert, edit and delete functions.
- Making on-line program changes.
- Searching a logic program for instructions and/or machine references.
- Performing optional dual use checking of discrete output references when instructions are entered.
- Monitoring reference data or I/O point status while viewing the logic program.
- Monitoring reference data in table form in binary, hexadecimal, or decimal format.
- Monitoring register reference data in timer/counter format.
- Making on-line reference data changes.
- Four PLC access privilege levels
- Using the OEM protection key.
- Configuring I/O modules.
- Viewing PLC scan time, firmware revision code, and current logic memory usage.
- Loading, storing, and verifying program logic and configuration from/to/with the Series 90 Memory Card or EEPROM.
- Starting or stopping the PLC from any mode of operation.

Keypad

The keypad on the Hand-Held Programmer consists of 42 keys, arranged as a matrix of six keys across by seven keys down. The keypad is color-coded for easier identification of the different keys. Becoming familiar with the programmer keys and their functions will increase your programming efficiency.

Some of the keys have multiple uses, depending on the current operating mode and function. A description of the valid keys and their usage is included in chapter 2, *Operation*, and also in the beginning of each chapter of this manual.

LCD Screen

Information is displayed on an LCD screen which is two lines by sixteen characters in size. The contents of the screen depends on the current operating mode and function. The intensity of the screen can be increased or decreased by inserting a Phillips-head screwdriver into the small square opening on the right side of the programmer and turning it to the right or left, accordingly.

PLC Communications

The Hand-Held Programmer communicates with an attached PLC through an RS-422 compatible port. The cable connection supplies power to the Hand-Held Programmer and indicates to the PLC that a Hand-Held Programmer is attached. Please refer to chapter 2, *Operation*, for cable connection information.

Memory Card Interface

An interface to a removable memory card is provided. This removable memory card is a Series 90 Memory Card (catalog number IC693ACC303). The interface is used for storage and /or retrieval of program logic and configuration data. Detailed information on using the memory card to read, write, and verify data can be found in chapter 2.

Operating Modes

The Hand-Held Programmer supports four major operating modes:

Mode 1. Program Mode:

Program mode is used to create, alter, monitor, and debug Statement List (SL) logic programs. Interaction (Read, Write, and Verify) with a Series 90 Memory Card or EEPROM is also possible in program mode. Please refer to chapter 5, *Program Edit*, for additional information on using program mode.

Mode 2. Data Mode:

Data mode enables you to view and alter values in various reference tables. Numerous display formats are also supported. Please refer to chapter 6, *Reference Tables*, for additional information on using data mode.

Mode 3. Protection Mode:

Protection mode enables you to control access to (protect) a programmable logic controller, including program logic, reference data, and configuration information. The use of this mode is optional. Additional information on protection mode can be found in chapter 7, *PLC Control and Status*.

Mode 4. Configuration Mode:

In configuration mode, you can define the makeup of I/O modules in the PLC, including both those I/O modules already installed as well as those to be installed at a later time. Additional information on configuration mode can be found in chapter 3, *PLC Configuration*, and chapter 4, *I/O Configuration*.

Several functions may be performed independent of the current mode of operation. These functions include mode selection and starting or stopping the PLC. Please refer to chapter 7, *PLC Control and Status*.

References

The data used in an application program is stored as either register or discrete references. When entering a statement list program you must assign references to data in the PLC system. A reference specifies both a memory type and a precise location within that memory type. For example: %I0001 specifies address 1 in discrete input memory and %R0256 specifies address 256 in register memory.

The %I symbol is used by the PLC to distinguish machine references from nicknames (the % symbol is not entered or displayed on the HHP).

The valid register and discrete references that are used with the Series 90-30 and Series 90-20 programmable logic controllers are described in the following two tables.

Table 1-1. Register References

Type	Description
%R	The prefix %R is used to assign system register references, which will store program data such as the results of calculations.
%AI	The prefix %AI represents an analog input register. This prefix is followed by the register address of the reference (for example, %AI0015). An analog input register holds the value of one analog input or other value.
%AQ	The prefix %AQ represents an analog output register. This prefix is followed by the register address of the reference (for example, %AQ0056). An analog output register holds the value of one analog output or other value.

Note

All register references are retained across a power cycle to the CPU.

Table 1-2. Discrete References

Type	Description
%I	<p>The %I prefix represents input references. This prefix is followed by the reference's address in the input table (for example, %I0121). %I references are located in the input status table, which stores the state of all inputs received from input modules during the last input scan.</p> <p>A reference address is assigned to discrete input modules using the Logicmaster 90-30/90-20 configuration software or the Hand-Held Programmer. Until a reference address is assigned, no data will be received from the module.</p>
%Q	<p>The %Q prefix represents physical output references. The dual use coil checking function of the HHP checks for multiple uses of %Q references with relay coils or outputs on functions. Beginning with Release 3 of Series 90-30 and Release 2 of Series 90-20 firmware, you can select the level of coil checking desired (SINGLE, WARNMULTIPLE, or MULTIPLE). Refer to Chapter 3 for more information about this feature.</p> <p>The %Q prefix is followed by the reference's address in the output table (for example, %Q0016). %Q references are located in the output status table, which stores the state of the output references as last set by the application program. This output status table's values are sent to output modules at the end of the program scan.</p> <p>A reference address is assigned to discrete output modules using the Logicmaster 90-30/20/Micro configuration software or the Hand-Held Programmer. Until a reference address is assigned, no data is sent to the module. A particular %Q reference may be either retentive or non-retentive.</p>
%M	<p>The %M prefix represents internal references. The dual use coil checking function of the HHP software checks for multiple uses of %M references with relay coils or outputs on functions. Beginning with Release 3 of Series 90-30 and Release 2 of Series 90-20 firmware, you can select the level of coil checking desired (SINGLE, WARNMULTIPLE, or MULTIPLE). Refer to Chapter 3 for more information about this feature. A particular %M reference may be either retentive or non-retentive.</p>
%T	<p>The %T prefix represents temporary references. These references are never checked for multiple coil use and can, therefore, be used many times in the same program even when coil use checking is enabled.</p> <p>Because this memory is intended for temporary use, it is never retained through power loss or RUN-to-STOP-to-RUN transitions and cannot be used with retentive coils.</p>
%S	<p>The %S prefix represents system status references. These references are used to access special PLC data, such as timers, scan information, and fault information. System references include %S, %SA, %SB, and %SC references.</p> <p>%S, %SA, %SB, and %SC can be used on any contacts.</p> <p>%SA, %SB, and %SC can be used on retentive coils -(M)-.</p> <p>%S can be used as a word or bit-string input reference to functions or function blocks.</p> <p>%SA, %SB, and %SC can be used as a word or bit-string input or output reference to functions and function blocks .</p>
%G	<p>The %G prefix represents global data references. These references are used to access data shared among several PLCs. %G references can be used on contacts and retentive coils because %G memory is always retentive. %G cannot be used on non-retentive coils.</p>

Transitions and Overrides

The %I, %Q, %M, and %G user references have associated transition and override bits. %T, %S, %SA, %SB, and %SC references have transition bits, but not override bits. The CPU uses transition bits for counters and transitional coils. Note that counters do not use the same kind of transition bits as coils. Transition bits for counters are stored within the locating reference.

In the Series 90-30 model 331, 340, 341, and 351 CPU, override bits can be set. When override bits are set, the associated references cannot be changed from the program or the input device; they can only be changed on command from the programmer. Neither the Series 90-30 model 311 or 313 CPU nor the Series 90-20 model 211 CPU supports overriding discrete references.

Retentiveness of Data

Data is said to be retentive if it is saved by the PLC when the PLC is stopped. Unless otherwise stated for a particular model of CPU, the Series 90 PLCs preserve program logic, fault tables and diagnostics, overrides and output forces, word data (%R, %AI, %AQ), bit data (%I, %S (%SC is retentive: not %SA or %SB), %G, fault bits and reserved bits), %Q and %M data (unless used with non-retentive coils), and word data stored in %Q and %M. %T data is not saved.

%Q and %M references are non-retentive (that is, cleared at power-up when the PLC switches from STOP to RUN) whenever they are used with non-retentive coils. Non-retentive coils include coils -(), negated coils -(/), SET coils -(S)-, and RESET coils -(R)-.

When %Q or %M references are used with retentive coils, or are used as function block outputs, the contents are retained through power loss and RUN-to-STOP-to-RUN transitions. Retentive coils include retentive coils -(M)-, negated retentive coils -(/ M)-, retentive SET coils -(SM)-, and retentive RESET coils -(RM)-. The last use of a %Q or %M reference on a coil instruction determines its retentive state.

Table 1-3. Range and Size of User References for the Series 90-30 PLC Models 311/313/331/340/341 CPUs

Reference Type	Model311/313 CPU		Model331/340/341CPU	
	ReferenceRange	Size	ReferenceRange	Size
User program memory	Not applicable	3K words	Not applicable	8K words (model 331) 40K words (model 341) 16K words (model 340)
Discrete inputs †	%I0001 - %I0512	512 bits	%I0001 - %I0512	512 bits
Discrete outputs †	%Q0001 - %Q0512	512 bits	%Q0001 - %Q0512	512 bits
Discrete globals	%G0001 - %G1280	1280 bits	%G0001 - %G1280	1280 bits
Internal coils	%M0001 - %M1024	1024 bits	%M0001 - %M1024	1024 bits
Temporary coils	%T0001 - %T0256	256 bits	%T0001 - %T0256	256 bits
System status references	%S0001 - %S0032	32 bits	%S0001 - %S0032	32 bits
	%SA001 - %SA032	32 bits	%SA001 - %SA032	32 bits
	%SB001 - %SB032	32 bits	%SB001 - %SB032	32 bits
	%SC001 - %SC032	32 bits	%SC001 - %SC032	32 bits
System register references	%R0001 - %R0512	512 words	%R0001 - %R2048 %R0001 - %R9999	2048 words (model 331) 9999 words (model 340/341)
Analog inputs	%AI001 - %AI064	64 words	%AI001 - %AI128 %AI001 - %AI1024	128 words (model 331) 1024 words (model 340/341)
Analog outputs	%AQ001 - %AQ032	32 words	%AQ001 - %AQ064 %AQ001 - %AQ256	64 words (model 331) 256 words (model 340/341)
System registers ‡	%SR001 - %SR016	16 words	%SR001 - %SR016	16 words

† The actual number of physical discrete inputs and outputs depends on the baseplate and modules installed. Unused references can be used as internal references in your program.

‡ For reference table viewing only; can not be referenced in a user logic program.

Table 1-4. Range and Size of User References for the Series 90-30 PLC Model 351 CPU

Reference Type	Model 351 CPU	
	Reference Range	Size
Userprogram memory	Notapplicable	40K words
Discreteinputs	%I0001 - %I2048	2048bits
Discreteoutputs	%Q0001 - %Q2048	2048bits
Discreteglobals	%G0001 - %G1280	1280bits
Internal coils	%M0001 - %M4096	4096bits
Temporary coils	%T0001 - %T0256	256 bits
System status references	%S0001 - %S0032	32 bits
	%SA001 - %SA032	32 bits
	%SB001 - %SB032	32 bits
	%SC001 - %SC032	32 bits
System register references	%R0001 - %R9999	9999 words
Analoginputs	%AI001 - %AI2048	2048words
Analogoutputs	%AQ001 - %AQ0512	512 words
System registers †	%SR001 - %SR016	16 words

† For reference table viewing only; can not be referenced in a user logic program.

Table 1-5. Range and Size of User References for the Series 90-20 PLC

Reference Type	Reference Range	Size
Userprogram logic	Notapplicable	1K words
Discreteinputs	%I001 - %I016	16 bits
Discrete inputs, internal	%I017 - %I048	32 bits
Discreteoutputs	%Q0001 - %Q0016	12 bits
Discrete outputs, internal with LED indicators	%Q013 - %Q016	4 bits
Discrete outputs, internal	%Q017 - %Q048	32 bits
Discreteglobals	%G0001 - %G1280	1280bits
Discrete internal coils	%M0001 - %M1024	1024bits
Discretetemporary coils	%T0001 - %T0256	256 bits
System status references	%S0001 - %S0032	32 bits
	%SA001 - %SA032	32 bits
	%SB001 - %SB032	32 bits
	%SC001 - %SC032	32 bits
System register references	%R0001 - %R0256	256 words
Analog and High Speed Counter inputs	%AI001 - %AI016	16 words
Analogoutputs	%AQ001 - %AQ016	16 words
System registers †	%SR001 - %SR016	16 words

† For reference table viewing only; can not be referenced in a user logic program.

Table 1-6. Range and Size of User References for the Series 90 Micro PLC

Reference Type	Reference Range	Size
User program logic	Not applicable	1K words
Discrete inputs	%I001 - %I016	16 bits
Discrete inputs, internal	%I017 - %I048	32 bits
Discrete outputs	%Q0001 - %Q0016	12 bits
Discrete outputs, internal with LED indicators	%Q013 - %Q016	4 bits
Discrete outputs, internal	%Q017 - %Q048	32 bits
Discrete globals	%G0001 - %G1280	1280 bits
Discrete internal coils	%M0001 - %M1024	1024 bits
Discrete temporary coils	%T0001 - %T0256	256 bits
System status references	%S0001 - %S0032	32 bits
	%SA001 - %SA032	32 bits
	%SB001 - %SB032	32 bits
	%SC001 - %SC032	32 bits
System register references	%R0001 - %R0256	256 words
Analog and High Speed Counter inputs	%AI001 - %AI016	16 words
Analog outputs	%AQ001 - %AQ016	16 words
System registers †	%SR001 - %SR016	16 words

† For reference table viewing only; can not be referenced in a user logic program.

Using the Hand-Held Programmer

When power is applied to the PLC, the Hand-Held Programmer begins diagnostic tests on its hardware. Once these tests are successfully completed, the Hand-Held Programmer can interact with the PLC.

Initially, you must select an operating mode: program mode, protection mode, data mode, or configuration mode. When setting up a new system, you will normally want to select configuration mode first, in order to configure the I/O modules to be used in the system. In configuration mode, you can identify which PLC backplane slots contain I/O modules, and the size (number of Input or Output points) for each module. Based on the size of each module, a range of discrete input and output references can either be assigned automatically by the Hand-Held Programmer, or optionally specified by the user. The configuration of these I/O modules can be changed at any time.

After configuring the I/O modules, the next step is to program the actual logic program. Program mode is selected for this. Once in program mode, you can create, modify, and monitor the execution of program logic instructions. The optional Series 90 Memory Card or EEPROM can be used at any point to save or recall a particular version of the program.

While attempting to debug a logic program, you may need to view and modify data in one or more reference tables. Selecting data mode allows you to accomplish this. Once in data mode, you can view any of the PLC reference tables in binary, hexadecimal, or signed decimal format. Only the system register (%R) table can be viewed in timer/counter format.

Once a system has been properly configured and its logic program is functioning correctly, you may want to protect parts of the system from any changes. Selecting protection mode allows you to password-protect certain types of changes. A special OEM protection feature can also be enabled to prevent unauthorized access.

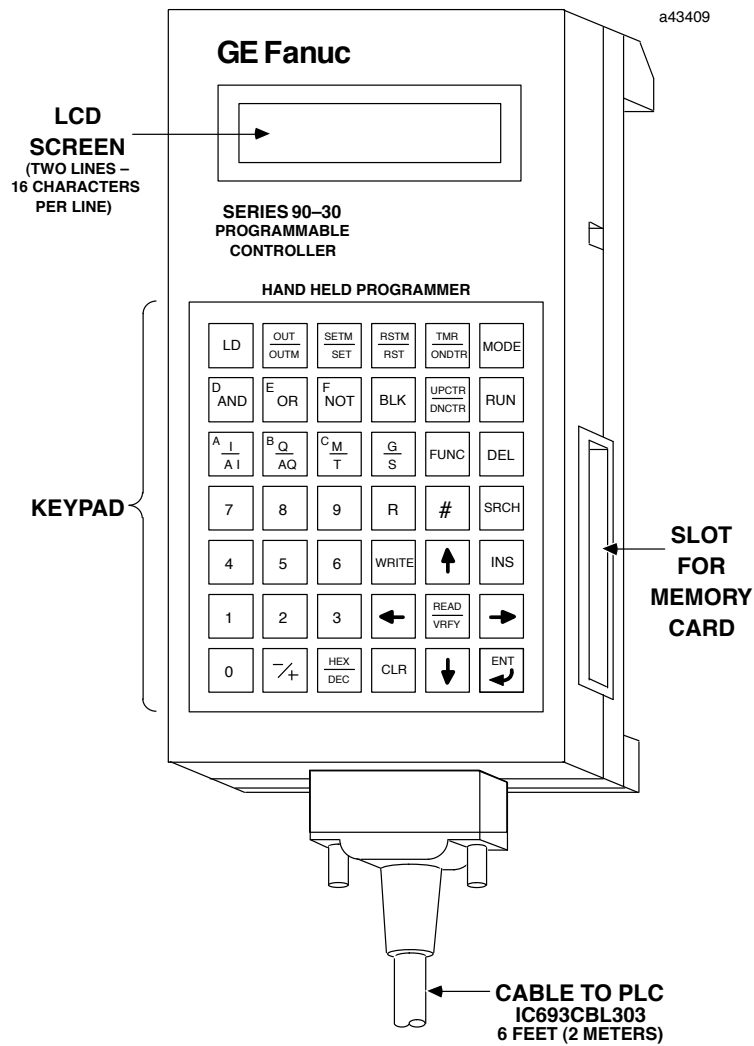

Figure 1-1. Series 90-30/20/Micro Hand-Held Programmer

Chapter 2

Operation

The setup and installation of the Hand-Held Programmer is easy. The Hand-Held Programmer connects to a Series 90-30, 90-20, or Micro Programmable Logic Controller through a cable attachment. The cable (catalog number IC693CBL303, 6 feet (2 meters) long) attaches to both the Hand-Held Programmer and the programmable controller through a latching connector (one on each end of the cable).

Power is supplied to the Hand-Held Programmer from the PLC through a connection in the cable. The cable connection also provides an indication to the PLC that a Hand-Held Programmer is attached as the programming device rather than a different programmer, since this is the same connection for the Logictmaster 90-30/20/Micro programmer.

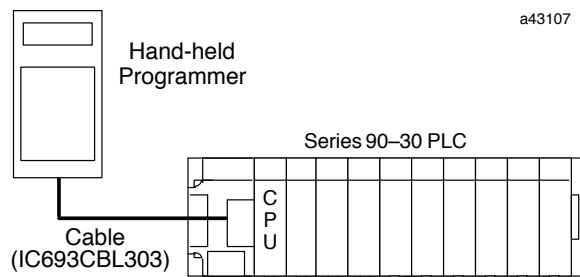

Figure 2-1. Hand-Held Programmer Connection to a Series 90-30 PLC

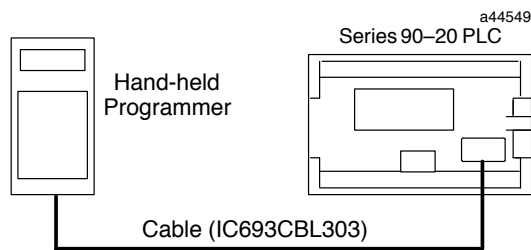

Figure 2-2. Hand-Held Programmer Connection to a Series 90-20 PLC

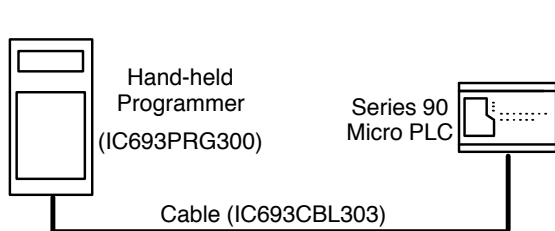

Figure 2-3. Hand-Held Programmer Cable Connection to a Series 90 Micro PLC

Powering up the Hand-Held Programmer

The Hand-Held Programmer may be connected to a programmable logic controller which is powered up, or it may be connected prior to power-up. When connected during power-up, the Hand-Held Programmer momentarily displays the following messages on the screen if no power-up diagnostic problems are found.

```
ROM CHECK OK
RAM CHECK OK
```

Following this momentary display, the screen will display *CONFIGURING SYSTEM*. The amount of time this is displayed can be as long as 7 seconds if there are intelligent modules plugged into the I/O slots. The initial screen displayed depends upon what was last displayed when the Hand-Held Programmer was powered down. If the last display was a data table in data mode, that same data table will be the first screen displayed when power is restored. If any other display in a different mode was displayed, the Mode Selection screen will be displayed when the Hand-Held Programmer is powered up again.

The following example shows the Hand-Held Programmer screen viewing the register (%R) table in timer / counter display format in data mode, with %R4 as the top reference displayed, when the unit was powered down.

```
T/C R0004 0 0 <R
      0      0
```

The same display returns after restoring power.

In the next example, the Hand-Held Programmer was viewing instruction step #0015 in program mode when the system was powered down.

```
#0015 <R
LD NOT S0001
```

In this case, the mode selection screen is displayed after restoring power.

```
- 1. PROGRAM <R
  2. DATA
```

Disconnecting the Hand-Held Programmer

The Hand-Held Programmer can be disconnected from the PLC while power is still applied. If this occurs in the middle of a modification operation, such as inserting a new logic instruction step, the operation is automatically canceled. The protection access level will be set to its default state. Refer to chapter 7, *PLC Control and Status*, for more information on password protection.

Keypad

The keypad consists of 42 keys, arranged as a matrix of six keys across by seven keys down, as shown in the following illustration.

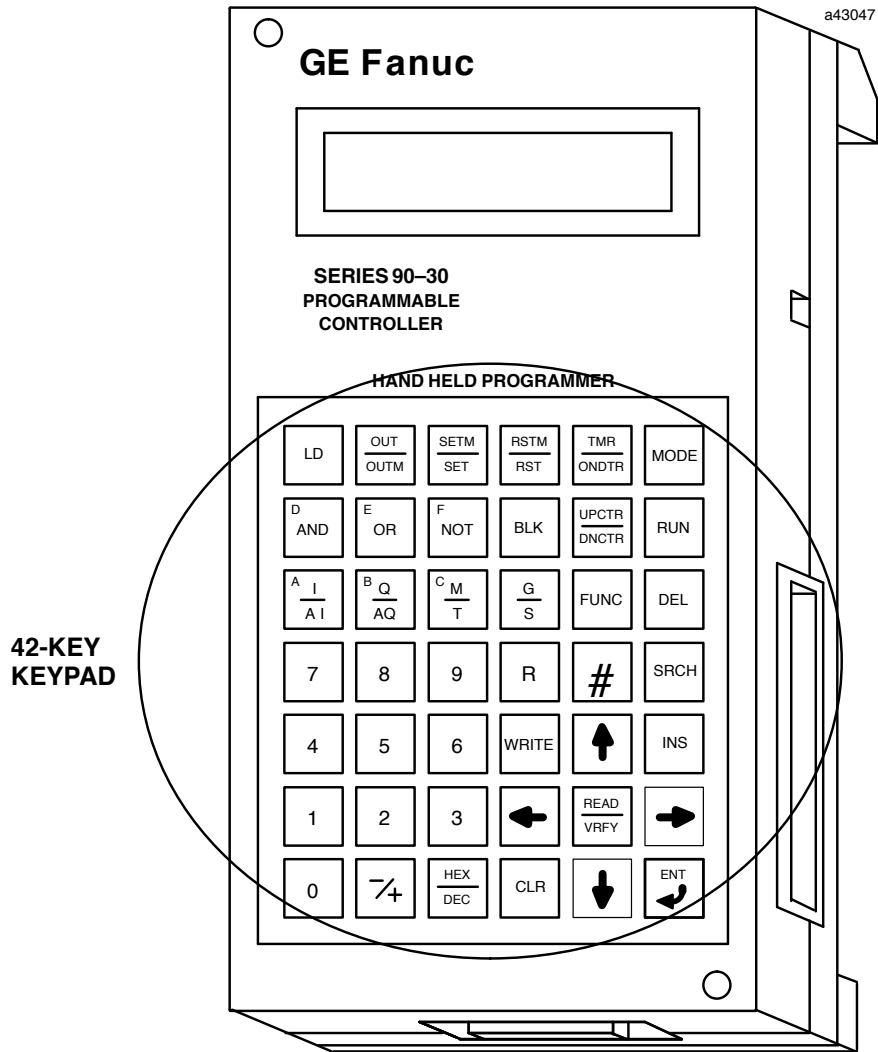

Figure 2-4. Hand-Held Programmer Keypad

The keypad on the Hand-Held Programmer is color-coded for easier identification of the different keys. Becoming familiar with the programmer keys and their functions will increase your programming efficiency.











Note

Several keys provide access to two instructions. To access the instruction printed on the lower half of the key, press the key twice.

Edit and Display Control Keys

The blue Edit and Display Control keys are located on the right side of the keypad. The CLR key is red. A description of these keys is provided in the following table:

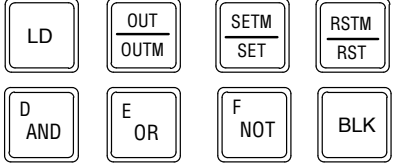
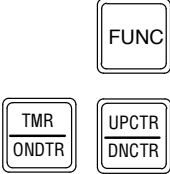
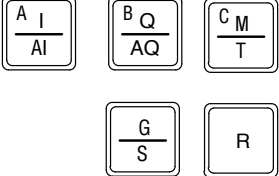
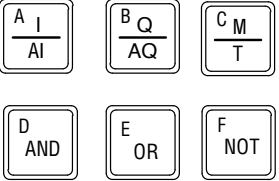

Table 2-1. Edit and Display Control Keys

Key	Description
	Select an HHP operating mode.
	Start or stop the PLC.
	Delete an instruction step in program mode. Delete configuration of currently displayed slot in I/O configuration mode. Delete password at specified access level in protection mode.
	Search for a given target or initiate a program check in program mode.
	Begin an instruction step insertion operation in program mode.
 	Move between instruction steps in program mode. Move view window around currently displayed table in data mode. Select an I/O slot for viewing in configuration mode. Enter a lower or higher access level in protection mode.
 	Move between function parameters in program mode. Invoke or abort a reference table contents change in data mode. Display a different PLC parameter, or position different binary bit for change in PLC configuration mode. Display a different module parameter or field in I/O configuration mode. Display password for lower or higher access level; view / modify OEM key in protection mode. Move between subroutines when in Subroutine Declaration mode.
	Complete an operation or user input.
	Abort or cancel the current operation or user input.

Ladder Logic Keys

The gray Ladder Logic keys are located on the upper portion of the keypad. These keys are used to enter the program elements that make up the user's program. A description of these keys is provided in the following table:

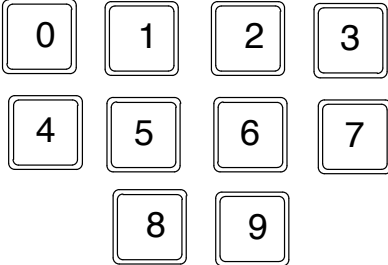

Table 2-2. Ladder Logic Keys

Key	Description
	<p>Program a boolean logic instruction in program mode.</p>
	<p>Program a function or function block instruction in program mode.</p> <p>Program TMR, ONDTR, UPCTR, DNCTR function blocks in program mode.</p> <p>Change data mode display format to timer / counter; automatically select register table if not displayed in data mode. (This does not apply to the FUNC key.)</p>
	<p>Specify a memory reference type in program and data mode.</p> <p>I/A and Q/AQ and G specify module types in configuration mode.</p>
	<p>Specify a binary, decimal (possibly signed) or hexadecimal value in program and data mode.</p> <p>Specify a slot number, reference address, point count or PLC parameter value; value format may be either binary, signed decimal, or hexadecimal in configuration mode.</p> <p>Specify the alpha characters of a 1 - 4 digit hexadecimal password value.</p>
	<p>Specify an instruction step in program mode.</p> <p>Override, or cancel the override on, a discrete reference in data mode.</p> <p>Indicate a new rack / slot number (GOTO) in configuration mode.</p> <p>Zoom into or out of subroutine logic.</p>

Numeric Keys

The white Numeric keys are located on the lower left side of the keypad. They include the keys for the numerals 0 through 9, the $-/+$ key, and the HEX/DEC key. A description of these keys is provided in the following table:



Table 2-3. Numeric Keys

Key	Description
	<p>Specify a binary, decimal (possible signed), or hexadecimal value in program and data mode.</p> <p>Specify a slot number, reference address, point count, or PLC parameter value; value format may be either binary, signed decimal, or hexadecimal in configuration mode.</p> <p>Specify a 1 - 4 digit hexadecimal password value in protection mode.</p>
	<p>Specify a binary, decimal (possible signed), or hexadecimal value in program and data mode.</p> <p>Toggle PLC configuration parameter setting in configuration mode.</p> <p>Toggle between run and stop mode in any mode.</p>
	<p>Specify a signed decimal or hexadecimal constant in program mode.</p> <p>Change display format between binary, signed decimal, and hexadecimal in data mode.</p> <p>Change display format between decimal, hexadecimal, and 8-bit binary in configuration mode.</p>

Program Transfer Keys

The Program Transfer keys are located in the blue shaded area in the lower right portion of the keypad. They include the READ/VERIFY and WRITE keys.

Table 2-4. Program Transfer Keys

Key	Description
	<p>Read or verify the memory card or system EEPROM in program mode.</p> <p>Read configuration of module currently installed in slot.</p>
	<p>Write the memory card or system EEPROM in program mode.</p>

Power-Up Key Sequences

The key sequences listed below can be used during power-up to provide additional start-up instructions for the PLC, or to override the previous configuration. When used to override the previous configuration these keys must be depressed simultaneously while the ROM CHECK OK & RAM CHECK OK screen is being displayed and held depressed until the mode screen is displayed on the HHP. (The keys must be pressed simultaneously until the *ROM CHECK OK, RAM CHECK OK* message is removed from the screen.)

During power-up, the PLC may be instructed to totally clear all data stored within it. This includes program logic, data tables, configuration, passwords, and the OEM key. To do this, press and hold the CLR and M/T keys simultaneously while the PLC is powering up. A ROM CHECK OK or RAM CHECK OK message is displayed on the Hand-Held Programmer screen upon receiving power. Double key strokes must be held until after the ROM CHECK OK and RAM CHECK OK message is cleared. *Note that power-up sequences from the HHP are not processed for warm start powerups.*







Caution

Do not press the CLR and M/T keys to clear memory if an OEM program is in RAM memory. All configuration data and logic will be lost.

The PLC can be configured to download a logic program during start-up from EEPROM (located in the EEPROM socket on the baseplate of the Model 311 and in the CPU module in a Model 331) to RAM, instead of running from the existing program in RAM. You can override this option when testing changes to the program so that the program in RAM is retained, and not overwritten by the program in EEPROM. To use RAM memory regardless of the configuration, press LD and NOT keys simultaneously while the PLC is powering up.

The PLC can be configured to power up in RUN or STOP mode, or in the same mode it was powered down in. This configured state can be overridden to ensure that the PLC will power up in STOP mode, regardless of the configuration. To do this, press NOT and RUN simultaneously during power-up until the *RAM CHECK OK, ROM CHECK OK* message is displayed on the screen.

Table 2-5. Power-Up Options

Key Sequence	Description
 	Totally clears all data stored within the PLC, including program logic, data tables, configuration, passwords, and the OEM key. Do not use this function if an OEM program is in RAM memory, as all configuration data and logic will be lost.
 	Prevents the PLC during power-up from downloading a program from EEPROM to RAM and puts the CPU in the STOP mode. Use RAM memory regardless of the configuration.
 	Ensures that the PLC powers up in the STOP mode.

Special Key Sequences

Table 2-6. Special Key Sequences

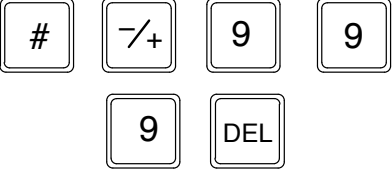
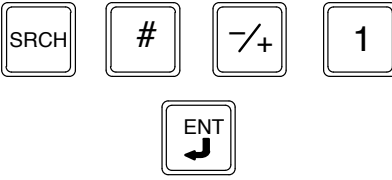
Key Sequence	Description
	Clear all program logic instruction steps from memory without affecting any other memory, such as data or configuration (only when in program mode, will not work in program insert mode).
	Begin the program check function (only when in program mode, will not work when in program insert mode).

Selecting an Operating Mode

In general, most functions are available only in a single mode of operation. To interact with a particular function, the correct mode of operation must first be selected.

1. Press the MODE key to select a new mode of operation. After pressing MODE, the following initial screen will be displayed:



2. Use the Up and Down cursor keys to scroll the menu selection display in order to view other possible selections. Each press of the Up cursor key scrolls the menu up one position; each press of the Down cursor key scrolls the menu down one position. Possible selections include:

- 1. PROGRAM
- 2. DATA
- 3. PROTECT
- 4. CONFIG

3. To select an operating mode, enter the single digit corresponding to the desired mode. The name of that mode does *not* have to be currently displayed on the menu display in order for that mode to be selected.
4. Press the ENT key to invoke the new mode.
5. One alternate method of selecting the operating mode is to use the Up and Down cursor keys to display the desired mode at the top of the screen and press the ENT key to execute the selection. If the desired mode is already displayed at the top of

the screen, simply press the ENT key. Pressing the ENT key with no mode value entered will execute the current top menu selection.

Modes 1, 2, 3, and 4 are currently the only modes supported. If any other number is entered on the mode selection screen, it will be ignored.

To cancel a mode change request, press the CLR key or press the desired new number.

Read/Write/Verify Functions

Support is provided for the storage of data in a secondary storage device. The secondary storage device may be either an EEPROM installed in the PLC backplane or a Series 90 Memory Card inserted into the Hand-Held Programmer. For either secondary storage device, the following PLC data is always stored:

- Program logic Statement List instructions.
- Registers.
- Slot configuration data.
- Passwords.
- OEM key.

Functionality is provided for writing, reading, and verifying this data with either an EEPROM or Series 90 Memory Card. *This functionality is available only in program mode, when the PLC is stopped and not scanning I/O.*

Series 90-30 CPU models 340, 341, and 351, and the Series 90 Micro PLC can have data written to flash memory. During a write to flash, there is no *in progress* indication. Other CPU models, that use EEPROM as a storage device, do have an *in progress* indication during a write operation.

Starting/Stopping the PLC

The PLC may be started or stopped while in the Mode Selection screen, or in any of the four major operating modes (program, data, protection, or configuration).

Selecting RUN/STOP Mode from Mode Selection Screen

The initial mode selection screen indicates that the PLC sweep is in the STOP mode as shown by the <S in the upper right corner of the display screen.

Initial display:



To select the RUN mode:

Press the  key:

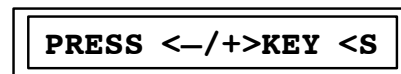

After exiting the RUN/STOP Sweep Mode function, the HHP will return you to the Mode Select menu.

Selecting RUN/STOP Mode from an Operating Mode

Before the PLC's operating state may be changed, a minimum access level of 2 must first be selected. If the access privilege is only level 1, the change mode request will be refused and a *PROTECT* error message will be displayed. See Chapter 7 for more information on *PROTECTION*.

Before the PLC's operating state is changed from stopped to running, the program is first checked to ensure that no syntax errors exist in the program. If an error is found, the request to execute the program is refused and an indication of the problem is displayed by an error message. By exiting the start/stop function and entering program mode if not already in that mode, you may view the instruction step containing the error. It is possible that the program may contain multiple errors; but only the first error detected, beginning with the start of the program, is displayed.

When making a mode change from STOP to RUN the following screen may be displayed:

```

CLEAR FAULTS? <S
<ENT>=Y <CLR>=N
```

This indicates that there is a fault in the CPU. Check the fault indicator system tables SA, SB, and SC. A fatal fault will not allow you to proceed into the run mode until it is removed and cleared. A diagnostic fault must be cleared. To clear faults, press the ENT key again. Press the CLR key to return to the stop mode and check tables for faults.

A change in the PLC operating state is first initiated by pressing the RUN key. The desired state, run mode or stop mode, is then selected. The -/+ key is used to toggle between the run mode and stop mode states. Pressing the -/+ key initially selects run mode; pressing the -/+ key again toggles the selection to stop mode. Each time you press the -/+ key, the mode is toggled. When the desired operating mode is displayed on the screen, press the ENT key.

In the following example, the current operating state of the PLC in the configuration mode is changed from run mode to stop mode.

1. If protect mode is selected, the initial display screen would appear as:

```

LEVEL3 <R
```

This screen indicates that the PLC is running (executing) a program, as shown by the <R in the PLC state field (upper right corner) of the display screen.

2. Press the RUN key to initiate a change in the PLC operating state:

```

PRESS <+/->KEY <R
```

3. Press the -/+ key to initially select run mode:

```

RUN MODE <R
```

4. Press the $-/+$ key again to toggle the selection to stop mode:

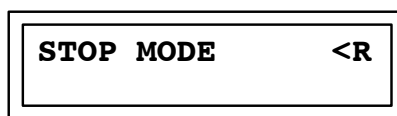

Each time the user presses the $-/+$ key, the mode is toggled. When the desired operating mode is displayed on the screen, the user initiates the change by pressing the [ENT] key.

5. Then, press the ENT key:

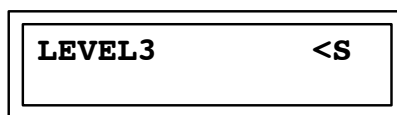

This screen indicates that the PLC is now stopped, as indicated by the <S in the PLC state field of the display screen.

Canceling a Mode Change

The CLR key may be used to cancel an operating mode change before activating it. Press the CLR key twice to exit from the mode change screen and return to the currently entered function.

User PROM Option

Application programs are normally developed in the CPU's RAM memory and executed from RAM memory. If additional program integrity is desired, or operation of the PLC without a battery is desired, an optional EEPROM or EPROM can be installed in a spare socket (labeled PROGRAM PROM) on the Model 311 backplane or in a socket on the Model 331 CPU module. EEPROMs can be written to and read from. EPROMs can be read when installed in the PLC, however they must be written to using an external PROM burning device. Non-removable *flash memory* performs this function on the Model 340, 341, and 351 CPUs.

A typical scheme for using these devices is to develop programs using an EEPROM. When the program in RAM has been developed and debugged, it is saved to EEPROM. The EEPROM can then be removed from the PLC and used as a master to make backup or multiple copies of the program to EPROM memory. The EPROM can then be installed in the socket provided in the CPU and used as a non-volatile memory for *battery-less* operation, or to run the same program in multiple PLCs. The Model 331 CPU has a jumper (JP1) located next to the EEPROM/EPROM socket to let you select between EEPROM or EPROM.

Jumper	Selects
3-2	EEPROM
2-1	EPROM

When the EEPROM or EPROM is installed, the application program stored in the device is automatically loaded into RAM memory whenever the CPU is powered-up. However, this only happens, if EEPROM is selected as the *Program Source* parameter during configuration with the Hand-Held Programmer or Logicmaster 90 configuration software.

Caution

If EEPROM is selected and a PROM is not in the socket or a blank PROM is in the socket, on a power-up cycle a blank program will be placed into the RAM memory, therefore the program in RAM will be lost.

EEPROM and EPROM memory chips are available from GE Fanuc. Catalog numbers for these devices are listed in the following table.

Table 2-7. EEPROM and EPROM Memory Catalog Numbers

Catalog Number	Description	GE Fanuc PROM Part Number	Third Party Source	
			Vendor	Part Number
IC693ACC305 (Qty 4)	28C256 EEPROM, 350ns	44A725999-000	XICOR	X28C256Por
			XICOR	X28C256-25
IC693ACC306 (Qty 4)	32Kx8 UV EPROM, 150ns	44A723379-000	NEC	PD27C256AD-15
			Atmel	AT27C256-15DC1
			Toshiba	TC57256AD-15
			Hitachi	HN27C256AG-15
			AMD	AM27C256-150DC
			Intel	TD27C256A-1

Installing a Blank EEPROM/EPROM

Use the following procedure for installing a blank EEPROM or EPROM in a Series 90-30 or Series 90-20 PLC.

Caution

You must be careful when installing a blank EEPROM or EPROM in the PROM socket of the CPU in a Series 90-30 or Series 90-20 or the program in RAM memory will be lost.

1. Configure the CPU to
 - PRG SRC RAM and REG SRC RAM**
 - (see NOTE at end of this procedure)
2. Remove power from the PLC.
3. Remove the CPU from its socket on the baseplate.
4. Remove the faceplate and LED lens cover from the CPU. The PROM socket is now accessible at the bottom of the CPU board.
5. Turn the screw at the center top of the socket counter clockwise so that the slot lines up with the **O**. This allows an EEPROM or EPROM to be inserted.

6. Insert the EEPROM or PROM into the socket with the notch facing the screw.
7. Turn the screw clockwise so that the slot lines up with the C. The EEPROM or EPROM is now locked into the socket.
8. Set the jumper plug at the bottom of the socket for EEPROM (3-2) or PROM (2-1), as required.
9. Replace the faceplate.
10. Insert the CPU into its connector in the baseplate.
11. Turn-on power to the PLC.
12. The CPU can now be configured to

PRG SRC EEPROM and REG SRC EEPROM

Note

If not configured for Program (PRG) and Register (REG) from RAM when power is applied after a blank EEPROM is inserted, the contents of the blank PROM will be loaded into the RAM memory. The CPU can be forced to load Program and Registers from RAM, if on power-up using the Hand-Held Programmer the LD and NOT keys are depressed simultaneously and held depressed during power-up until the MODE selection menu is displayed.

Series 90 Memory Card

In addition to EEPROM a Series 90 Memory Card inserted into the Hand-Held Programmer may be used to save, retrieve or verify program logic data and configuration data contained on it versus the actual PLC contents. The Series 90 Memory Card *is not supported* by the Model 351 CPU.

If the memory card or EEPROM has not been properly inserted before attempting a write, read, or verify operation, the absence of the card or EEPROM will be detected as an error and an error message will be displayed.

The PLC must also be stopped and must not be scanning I/O before you can perform a memory card or EEPROM operation. If you attempt to write, read, or verify data when the PLC is running, a *RUNNING* error message will be displayed on the screen. You must first stop the PLC before attempting the desired operation again. Also, when the CPU is configured for DO I/O, a *DO I/O* error message will be displayed on the screen. Change the CPU configuration STOP MD DO I/O to STOP MD NO I/O.

It is possible that a communications error between the Hand-Held Programmer and the memory card may occur during a write, read, or verify operation. If this occurs, the operation will be canceled and a *COMM ER* error message will be displayed. Make sure that the memory card is properly seated in the Hand-Held Programmer slot, before attempting the operation again.

The following screen format is used to write, read, or verify the memory card or EEPROM.

Table 2-8. Read/Write/Verify Series 90 Memory Card or EEPROM

Operation	Device			<S
	Device Address			

Operation:

The operation field indicates the particular operation which is to be performed on the destination device, MEM CARD or EEPROM. Its modes of operation are listed below, along with a description of each.

MODE OF OPERATION	DESCRIPTION
READ	Read the contents of the memory card or EEPROM into RAM.
WRITE	Write the contents of RAM to the memory card or EEPROM.
VERIFY	Verify contents of the memory card or EEPROM with RAM.

Device: This field identifies the destination device, which in this case, is the Series 90 Memory Card or EEPROM. This field may also function as an error message window if you attempt a read, write, or verify operation without a memory card or EEPROM properly inserted.

<S: <S indicates that the PLC is currently stopped. The PLC must be in STOP NO I/O before you can perform a read, write, or verify operation. <R displayed in this field would indicate that the PLC is currently running (executing a program). If you attempt an operation with the PLC running or in STOP DO I/O, an error message is displayed on the screen and the operation will not be performed.

Device Address: This number is continuously updated while the device is being read/written to indicate that the operation is in progress.

Loading RAM from the Memory Card or EEPROM

To read (load) the contents of a previously programmed Series 90 Memory Card or EEPROM into RAM memory, follow this procedure:

1. In program mode, press the READ/VERIFY key:

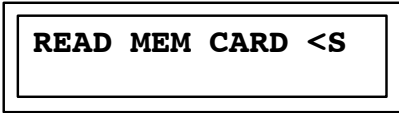

If EEPROM is desired, press the -/+ key to toggle the selection to EEPROM.

2. Then, press the ENT key twice to complete the read operation (see *Reading Program Logic Only* for selective read). The above screen will be displayed while the transfer is taking place. This time is approximately 1:35 (one minute, 35 seconds) for an OK program in a Model 311.

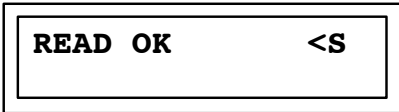

Storing RAM to the Memory Card or EEPROM

To store (write) a copy of the contents of RAM memory into a Series 90 Memory Card or EEPROM, follow this procedure: (Note: for the Model 340 or 341, use steps 1, 2, and 3; for all other models use only steps 1 and 3)

1. In program mode, press the WRITE key:

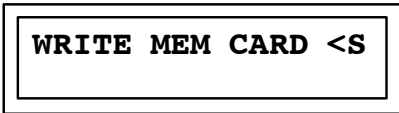

If EEPROM is desired, press the -/+ key to toggle the selection to EEPROM.

2. Then, in the Model 340 or 341, press the ENT key to choose the number of registers to save (either 9999 or 2048). The second line of the display will read:

REGS TO SAVE: 9999

To save 2048 registers instead, press the -/+ key to toggle the selection to 2048.

3. For all models, press the ENT key to complete the write operation. The above screen will be displayed while the transfer is taking place. This time is approximately 1:35 (one minute, 35 seconds) for an OK program in a Model 311.

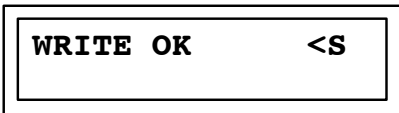

In order to write data, the memory card must not be write-protected (through the tab on the card). If it is write protected when a write operation is requested, the write protect will be detected and the request refused. A *PROTECT* error message will be displayed on the screen. Remove the write protect condition from the Series 90 Memory Card before attempting another programming operation.

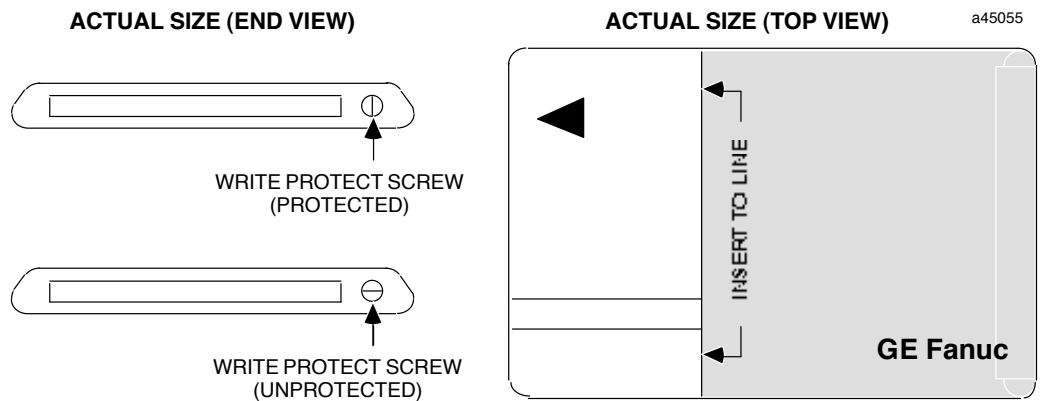

Figure 2-5. EEPROM Memory Card (Catalog Number IC693ACC303)

Verifying RAM with the Memory Card or EEPROM

To manually verify the contents of a previously programmed Series 90 Memory Card or EEPROM with the PLC's RAM memory, follow this procedure:

1. In program mode, press the READ/VERIFY key twice:

VERIFY MEM CARD <S

If EEPROM is desired, press the -/+ key to toggle the selection to MEM CARD or EEPROM.

2. Then, press the ENT key twice to complete the verify operation (see *Reading Program Logic Only* for selective read):

VERIFY OK <S

Error Messages During EEPROM/MEM Card Operation

The following error messages may occur during EEPROM/MEM card operations.

NO PRIV: Current privilege level of the PLC is too low for the intended operation (see Chapter 7).

NO CARD: No memory card is inserted in the Hand-Held Programmer, or the inserted card has insufficient capacity for the operation.

CFG ERR: The I/O configuration saved in the memory card is incompatible with the target PLC (for example, EEPROM has a PCM configured and the target PLC is 311/211).

ROM ERR: No EEPROM installed or EEPROM data has been corrupted or never been written.

COMM ERR: The PLC model number saved on the device cannot be read into the PLC or a data error occurred while reading a memory card.

PROTECT: The memory card is write protected.

VERFY ERR: The data in the device does not exactly match the data in PLC RAM.

PSW ERR: An attempt was made to read a configuration enabling passwords into a PLC with passwords disabled or with an active password.

PRG ERR: The program saved in the device cannot be read into this PLC (for example, the saved program reference is %R2000 and target PLC is a model 311 or 211).

DO I/O: CPU is configured for STOP MD DO I/O reconfigure the CPU for STOP MD NOI/O.

Program/Configuration Portability

Programs, configuration, and registers can be transported from one model to a different model of a Series 90-30 or Series 90-20 CPU. This can be done using either an EEPROM, a MEM card, or a UVEPROM (if copied from an EEPROM). In this discussion these devices will be referred to as *the device*, since all of the rules apply equally to all three. The model of the CPU from which the device was written is referred to as the source CPU. The model of the CPU into which the contents of the device will be read is referred to as the target CPU.

There are certain restrictions on this portability as listed below:

1. Programs must be compatible with the target CPU. That is, they must not have references to addresses which do not exist in the target CPU and they must fit into the size restrictions of the target CPU. If non-valid references are attempted and this error is detected by the PLC, a PRG ERR message will be reported to the user by the HHP.
2. Configurations must be compatible with the target CPU. That is, they must not contain modules not supported by the target CPU nor have modules in racks not supported by the target CPU. If this error is detected by the PLC, then a CFG ERR message will be reported to the user by the HHP.
3. When reading configurations from a model which supports more slots into a CPU which supports fewer slots, the slots higher than those supported by the target CPU must be EMPTY.
4. When reading configurations from a model which supports fewer slots into a CPU which supports more slots, the slots in the target CPU beyond those supported by the source CPU will be set to EMPTY.
5. When reading registers from a CPU which supports a different number of registers than the target CPU, those registers higher than those supported by the smaller CPU will be ignored.
6. When configuration is read from one CPU model into a different model, the PLC must change the CPU model in the configuration to match the target model. After this configuration has been read and the model changed, the contents of the configuration in RAM memory cannot be verified with the contents of the configuration on the device.
7. The Model 351 CPU does not support the Series 90 Memory Card *and* its flash memory is not removeable. Transporting programs to and from Model 351 CPUs is done using Logicmaster -30/20/Micro software. *With this exception, the following discussions on reading the device also apply to reading data from the Model 351 flash memory.*

A list of the error messages which can be produced as a result of attempting to read a device can be found in Chapter 9 in this manual along with a description of possible causes and corrective actions.

If the entire contents of the device are not read, then the data which was not read remains intact within the PLC. For example, if only the program is being read, then the configuration and registers will remain unchanged by the attempted read, regardless of any errors encountered while reading the program.

Examples of program / configuration compatibility operations with the HHP are shown on the following pages.

Reading the entire device

To read (load) the entire contents of an EEPROM previously programmed from the same CPU model follow this procedure:

In PROGRAM mode, press the  key:

READ MEM CARD <S

To select which items will be read:

Press the  key:

**READ MEM CARD <S
PRG CFG REG**

To read the logic program, configuration, and registers saved on the card:

Press the  key:

**READ MEM CARD <S
PRG CFG REG xxxx**

The address at the end of the lower line will be continually updated as the read operation progresses.

If the read is completed successfully, the HHP will display:

READ OK <S

If an error is encountered during the read operation, an error message will be displayed, for example:

READ PRG ERR <S

If a program error is read, the contents of the PLC will be cleared (program, configuration, and registers).

Reading Program Logic Only

If desired, you can read only the program logic from the device, ignoring the configuration and register data which was saved on the device. To do this use the following procedure:

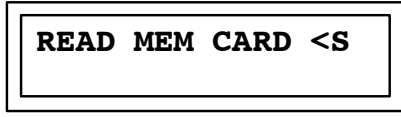
In PROGRAM mode, press the  key: 

To select which items will be read:

Press the  key: 

To read only the program logic:

Press the  key: 

Each time that you press the -/+ key allows the selection of other combinations of program, configuration, and/or registers which will be read from the device. All possible combinations of these three data types can be read. When the lower line of the display contains the desired combination to be read:

Press the  key: 

Note that the address displayed at the end of the lower line will be continually updated as the read operation progresses.

If the read is completed successfully, the HHP will display:

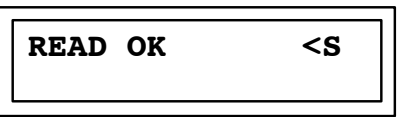

If an error is detected during the read operation, an error message will be displayed, for example:



If an error is detected, the contents of the PLC logic program will be cleared. If the attempt had been to read more than one type of data (for example, program and registers), then each of those types of data would have been cleared upon detection of an error.

Differing CPU Models

If the CPU model of the source PLC is not the same as the CPU model of the target CPU, then the model must be changed when the configuration is read from the device. For example, the device may have been written using a Series 90-20 model 211 CPU and the contents of the device are being read into a Series 90-30 model 311 CPU. This changing of the CPU model type applies ONLY when reading configuration.

To read the contents of a device from a different CPU model, use the following steps:

In PROGRAM mode, press the  key: 

Press the  key: 

To select which items will be read:

Press the  key: 

To read the logic program, configuration, and registers saved on the card:

Press the  key: 

The address at the end of the lower line will be continually updated as the read operation progresses. If the read is completed successfully, the HHP will display:



To change the model of the configuration being read into the PLC (the device contents will be unaffected):

Press the  key:



If you do not want to change the model number of the new configuration (thereby rejecting the data and aborting the read), use this step:

Press the  key:

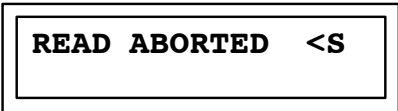

If the read operation is aborted, the contents of the memory areas in the PLC which were being read from the device will be cleared. For example, if program and configuration is being read and you elect to not change the model number, both the program and configuration will be cleared.

EEPROM Source at Power-Up

If the EEPROM is chosen as the program source during the power-up sequence, then the contents of the EEPROM will be rejected in its entirety if the EEPROM configuration is not compatible with the CPU model in which it is installed. The EEPROM used as a program source during power-up **MUST** have been written by a CPU of the same model. If the models differ, or if the configuration is incompatible with the CPU in which it is installed, the program, configuration, and registers in RAM memory will be cleared and the PLC will power up in STOP mode. If this happens, a fatal fault will be generated.

Before Power Cycle		After Power Cycle		CPU will run with program that was in
Configuration of Program Source CPU		Configuration of Program Source CPU		
RAM	EEPROM	RAM	EEPROM	
RAM	RAM	RAM	RAM	RAM
EEPROM	RAM	RAM	RAM	EEPROM
EEPROM	EEPROM	EEPROM	EEPROM	EEPROM
RAM	EEPROM	EEPROM	EEPROM	EEPROM
EEPROM	Blank EEPROM present	RAM	-	Blank
EEPROM	No EEPROM present	RAM	-	Blank, no program

Chapter 3

Series 90-30/20 PLC Configuration

A number of PLC parameters are user-configurable. Each of these parameters has a default value which, for many users, will not need to be changed. These parameters, their selections and default selections are shown in the following table.

Note

This chapter describes configuration for the Series 90-30 and 90-20 PLCs. See Chapter 4 for configuration information for the Micro PLC.

Table 3-1. User-Configurable PLC Parameters

Parameter	Selections	Default Value
Key click	ON (ENABLED) OFF (DISABLED)	OFF
Time of day clock (Not available on Model 311/321, Model 313/323, or Model 211)	Month Day Year Hour Minute Second	
Program source	RAM EEPROM	RAM
Register source	RAM EEPROM	RAM
Power-up mode	RUN STOP SAME PD	SAME PD
Active Constant Sweep Mode	DISABLE ENABLE	DISABLE
Active Constant Sweep Setting	5 - 200 msec	100 msec
Configured Constant Sweep Mode	DISABLE ENABLE	DISABLE
Configured Constant Sweep Setting	5 - 200 msec	100 msec
I/O scan in stop mode	NOI/O DOI/O	NOI/O
Dual use checking	SINGLE WRN MUL MULT	SINGLE
Port idle time	1 - 60 seconds	10 seconds

Table 3-1. User-Configurable PLC Parameters (continued)

Parameter	Selections	Default Value
Baud rate	300 600 1200 2400 4800 9600 19.2k	19.2k
Databits	7 BITS 8 BITS	8 BITS
Stop bits	1 BIT 2 BITS	1 BIT
Parity	ODD NONE EVEN	ODD
Modem turnaround time	0 to 255 counts	0
Disable passwords	ENABLE DISABLE	ENABLE
CPU ID	6 ASCII characters 0 - F	000000
Default I/O Configuration	ENABLE DISABLE	ENABLE
Checksum Words Per Sweep	8 through 32	8

This chapter describes how each parameter is configured.

The initial screen displayed in configuration mode is the last one viewed the previous time configuration mode was selected, since the PLC was powered up. If this is the first time configuration mode was entered, slot 1 of rack 0 (Model 331 / 340 / 341 / 351 CPU rack) or slot 0 of rack 0 (Model 311 / 313) is displayed.

Entering Configuration Mode

In order to view and/or change the PLC parameters, you must first select the configuration mode of operation.

1. To select configuration mode, press the MODE key to display the operating mode selections.



2. Press the 4 key to select configuration mode.



3. Press the ENT key to enter the new mode.

The first screen displayed will be R0:00 for Model 311/321 and 313/323 or R0:01 for Model 331/340/341/351 and Model 211 (Model 211 is Series 90-20). This is the first PLC configuration screen displayed. Use the Z \updownarrow keys to view the other parameters and the -/+ key to select the variable for a parameter.

R0:00 PLC <S KEY CLK: OFF

Keypad Functionality

The following table gives an overview of how the keypad on the Hand-Held Programmer is used in PLC configuration mode.

Table 3-2. Keypad Functionality in PLC Configuration Mode

Key Group	Description
0 - 9 I/AI (A) Q/AQ (B) M/T(C) AND(D) OR (E) NOT (F)	Specify a slot number or PLC parameter value; value format can be either binary, signed decimal, or hexadecimal. (A)...(F) - these keys are used for entering hexadecimal digits A....F.
HEX/DEC	Change the display format between decimal, hexadecimal, and 8-bit binary.
-/+	Toggle the PLC configuration parameter setting.
CLR	Abort or cancel the current operation or user input.
Up and Down cursor keys	Select an I/O slot for viewing.
Left and Right cursor keys	Display a different PLC parameter, or position different binary bit for change.
#	Indicate a new rack / slot number (GOTO).
ENT	Complete an operation or user input.
RUN	Start or stop the PLC.
MODE	Select an HHP operating mode.

Display Format

The following screen format is used for configuring the PLC parameters:

Table 3-3. Configuration Screen Format

R	Rack #	:	Slot #		Module Type or Message		PLC State
Parameter Label & Parameter Value							

Rack #: Slot #: The rack #: slot # field indicates the currently displayed rack and slot. For configuration purposes, the model 311 and 313 CPU module is embedded in the backplane. The Model 331/340/341/351 and Model 211 CPU module is *always* located in slot 1 of rack 0.

Module Type or Message: The module type or message field normally displays the designation *PLC*, indicating that PLC parameters are being configured. This field also functions as an error message window.

PLC State: The PLC state field indicates whether the PLC is currently stopped or is running (executing a program). A leading < character, followed by S if the PLC is stopped or R if it is running, indicates the state of the PLC.

Parameter Label: The parameter label field contains a text string which is used as a prompt to the user for a particular parameter.

Parameter Value: The parameter value field contains a value input by the user.

Locating a Slot or Rack and PLC Parameters

For configuration purposes, the Model 311/321 and 313/323 CPU (slot 0 of rack 0) is embedded in the backplane. The Model 331/340/341/351 and 211 CPU module is *always* located in slot 1 of rack 0.

The Up and Down cursor keys can be used to view the previous or next slot in the rack. If the current slot is at the end of the current rack, the next slot displayed will be the adjacent slot in the next/previous rack. For Model 211 slot 2 is always inputs, slot 3 is always outputs and slot 4 is always High Speed Counter.

The # key, in conjunction with a slot number, can be used to *go to* a particular slot, as shown in the following example.

1. When configuration mode is selected, the first screen displayed is the last slot viewed the last time this mode was entered (except after power-up). For this example, assume that slot 3 of the main rack was the last slot viewed:



- Press the # key to begin the GOTO operation:

```

R0:03 EMPTY <S
R_

```

- Enter the number of the rack which contains the slot you want to *go to*. For this example, enter a zero (0) for the main rack:

```

R0:03 EMPTY <S
R0:_

```

- Then, enter the number of the slot you want to *go to*. For this example, enter a 1 for slot 1 of the main rack:

```

R0:03 EMPTY <S
R0:1_

```

- Then, press the ENT key. Slot 1 of the main rack is now displayed on the screen:

```

R0:01 PLC <S
KEY CLK: OFF

```

If a rack number greater than the maximum supported by the system is indicated, the highest numbered rack will be displayed by default.

If a slot number greater than the maximum supported by the rack is entered as part of the GOTO operation, the greatest numbered slot within the rack will be displayed by default. For example, if the rack only contains five slots and you attempt to *go to* slot 9, slot 5 will be displayed on the screen of the Hand-Held Programmer.

In either case, no error message will be displayed.

Key Click Parameter

When viewing the PLC configuration, the first parameter field encountered is the key click (KEY CLK) parameter. By default, no audible click is heard when a key is pressed. You can choose an audible feedback from the keys by enabling this parameter. Use the -/+ key to toggle the selection between enabled (ON) and disabled (OFF).

Clock Parameter

The models 331, 340, 341, and 351 CPUs support a time-of-day clock. The month, day, year, hour, minutes, and seconds can be set by the user.

Use the Right cursor key to scroll through the PLC parameters until the clock parameter is displayed. Then, continue to press the Right cursor key to select each of the clock parameters, in turn. To change a parameter, enter the new value and press the ENT key.

Program Source Parameter

At power-up, you can specify that the program copy in RAM should be used, or that the program copy in EEPROM should be loaded into RAM and used. This can be helpful when you are running a program without battery backup.

Use the Right cursor key to scroll through the PLC parameters until the program source (PRG SRC) parameter is displayed. Then, use the -/+ key to toggle the selection between RAM and EEPROM. By default, the program copy in RAM will be used.

Register Source Parameter

At power-up, you can specify that the register table (R) values in RAM should be used, or that the register table initialization values in EEPROM should be loaded into RAM and used. This is also useful when you are running a program without battery backup.

Use the Right cursor key to scroll through the PLC parameters until the register source (REG SRC) parameter is displayed. Then, use the -/+ key to toggle the selection between RAM and EEPROM. By default, the register table copy in RAM will be used.

Note

Setting this parameter to EEPROM has no effect unless Program Source is also set to EEPROM.

Power-Up Mode Parameter

The PLC can be configured to always power up in one of these modes:

1. RUN mode.
2. STOP mode.
3. The SAME mode Powered Down in (SAME PD).

STOP mode should be used when the program is not fully debugged or requires manual intervention during start-up. RUN mode, on the other hand, should be used when manual intervention is neither required nor allowed. The normal selection for this parameter is to power up in the SAME mode that the system was powered down in.

Use the Right cursor key to scroll through the PLC parameters until the power-up mode (PU MODE) parameter is displayed. Then, use the -/+ key to toggle the selection between STOP, RUN, and SAME PD.

By default, the PLC will power up in the SAME PD mode powered down in.

Active Constant Sweep Mode Parameter

The PLC can be configured during RUN mode to use a constant amount of time per sweep. The active constant sweep mode parameter gives you the ability to enable or disable the constant sweep mode while the program is running, and have the effects noticed immediately. This parameter can be used to toggle the sweep mode of the PLC without changing the configured constant sweep mode parameter. The active constant sweep mode parameter, once changed, is only valid during the current RUN mode.

When going from STOP to RUN mode, the configured sweep mode parameter value is copied to the active sweep mode parameter.

Use the Right cursor key to scroll through the PLC parameters until the active constant sweep mode (ACT CNSW) parameter is displayed. Then, use the -/+ key to toggle the selection between DISABLE and ENABLE. By default, the PLC will execute every sweep as fast as possible.

Active Constant Sweep Setting Parameter

If the Constant Sweep Mode is enabled in the PLC during RUN mode, then the Active Constant Sweep Setting parameter can be used to adjust the sweep time. This allows you to fine tune the sweep time while the PLC is running a program. Changing this parameter does not affect the Configured Constant Sweep Setting parameter. The Active Constant Sweep Setting is only valid during the current RUN mode, as long as Active Constant Sweep Mode is enabled. Upon going from STOP to RUN mode, the Configured Sweep Setting parameter value is copied to the Active Sweep Setting parameter. If the Active Constant Sweep mode is disabled, this parameter is ignored. The active constant sweep value can range between 5 and 200 milliseconds.

Use the Right cursor key to scroll through the PLC parameters until the Active Constant Sweep setting (ACT CONS TM) parameter is displayed. To set the active sweep time, enter a value between 5 and 200 milliseconds, and press the ENT key. The default setting is 100 milliseconds.

Configured Constant Sweep Mode Parameter

The PLC can be configured to use a constant amount of time per sweep. The Constant Sweep Mode parameter should be enabled when I/O points or register values must be polled at a constant frequency, such as in control algorithms. The Configured Sweep Mode parameter can be overridden by the Active Constant Sweep Mode parameter during RUN mode, but upon going from STOP to RUN mode, the Configured Sweep Mode parameter value is copied to the Active Constant Sweep Mode parameter (see Active Constant Sweep Mode Parameter). The Configured Sweep Mode parameter can only be edited during STOP mode.

Use the Right cursor key to scroll through the PLC parameters until the Configured Constant Sweep mode (CFG CNSW) parameter is displayed. Then, use the -/+ key to toggle the selection between DISABLE and ENABLE. By default, the PLC will execute every sweep as fast as possible.

Configured Constant Sweep Setting Parameter

If the Configured Constant Sweep mode is enabled in the PLC, the sweep time value must also be selected. The Configured Constant Sweep Setting parameter can be overridden by the Active Constant Sweep Setting parameter during RUN mode, but upon going from STOP to RUN mode, the Configured Constant Sweep Setting parameter value is copied to the Active Constant Sweep Setting parameter. This allows you to maintain a configured setting, while fine tuning the setting during RUN mode with the active Constant Sweep Setting parameter. If the Configured Constant Sweep mode is disabled, this parameter is ignored. The Configured Constant Sweep value can range between 5 and 200 milliseconds.

Use the Right cursor key to scroll through the PLC parameters until the Configured Constant Sweep Setting (CFG CONS TM) parameter is displayed. To set the sweep time, enter a value between 5 and 200 milliseconds, and press the ENT key. The default setting is 100 milliseconds.

I/O Scan in Stop Mode Parameter

By default, the PLC will not scan I/O in stop mode. Enabling this parameter, however, allows you to debug and test input and output wiring without a control program installed.

Use the Right cursor key to scroll through the PLC parameters until the I/O scan in stop mode (STOP MD) parameter is displayed. Then, use the -/+ key to toggle the selection between NO I/O and DO I/O.

Dual Use Checking Parameter

The dual use checking parameter allows you to select whether or not %M and %Q references should be restricted to single use as outputs within the user logic program. When enabled, the system will not allow you to assign the same reference to two different coils.

Note

This feature is not editable in a Model 351 CPU, since this parameter applies to the user program, not the configuration.

Use the Right cursor key to scroll through the PLC parameters until the dual use checking (COIL US) parameter is displayed. Then, use the -/+ key to toggle between SINGLE, WRN MUL, and MULT. By default, WRN MUL is enabled. When toggling from MULT to SINGLE or WRN MUL, the program is checked for multiple coil usage. If multiple coils are detected, you can go to program mode and find the multiple coil usage with the SRCH, #, -1 key sequence. When going to SINGLE, the transition is not allowed; when going to WRN MUL, the transition is allowed. SINGLE check prevents using the same %M or %Q coil reference in two or more locations in the program. WRN MUL allows multiple coil uses of the same %M or %Q reference, but provides a warning screen to the user that this is being done, and MULT allows multiple coil usage without a warning.

Note

When an instruction is added and the *coil use* warning message is displayed, the warning message should be verified with the search function. It is possible that the use warning message is displayed even though the coil is used only once in the program.

The PLC parameters described on the following pages are controlled by the Hand-Held Programmer, **but do not affect its operation**. They are used for communications through the power supply port with devices other than the HHP.

Port Idle Time Parameter

This parameter allows you to specify the maximum amount of time a communications attachment to the PLC can be idle (no communications) before the PLC assumes that communications has either been lost or terminated. The maximum allowable idle time can range between 1 and 60 seconds, inclusive. The default value is 10 seconds.

Use the Right cursor key to scroll through the PLC parameters until the port idle time (IDLE TM) parameter is displayed. To specify the amount of allowable idle time, enter a value between 1 and 60 seconds, inclusive, and press the ENT key.

Baud Rate Parameter

The baud rate assigned to the communications port is selectable. The baud rates supported are 300, 600, 1200, 2400, 4800, 9600, and I will add the Range function 19.2k with the default setting at 19.2k.

Use the Right cursor key to scroll through the PLC parameters until the baud rate (BAUD RT) parameter is displayed. Then, use the -/+ key to toggle the selection between the baud rates supported.

Data Bits Parameter

You can select either 7 or 8 data bits per word for Series 90 Protocol (SNP) communications. The default value is 8 data bits per word.

Stop Bits Parameter

You can also select either 1 or 2 stop bits for Series 90 protocol communications. The default value is 1 stop bit.

Use the Right cursor key to scroll through the PLC parameters until the stop bits (STOP BT) parameter is displayed. Then, use the -/+ key to toggle the stop bits selection between 1 BIT and 2 BITS.

Parity Parameter

The selections for parity in Series 90 protocol communications include even, odd, and no parity. Odd parity is the default value parity.

Use the Right cursor key to scroll through the PLC parameters until the parity parameter is displayed. Then, use the -/+ key to toggle the parity selection between ODD, NONE, and EVEN.

Modem Turnaround Time Parameter

This parameter allows you to configure the turnaround delay time required for a particular modem. You must specify a given number of *counts*, where each count represents 0.01 seconds (10 msec). The number of counts can range from 0 (0 msec delay) to 255 (2.55 sec delay). Use 0 (zero) for direct connection with no turnaround time.

Use the Right cursor key to scroll through the PLC parameters until the modem turnaround time (MDM TAT) parameter is displayed. To specify the number of counts, enter a value between 0 and 255, inclusive, and press the ENT key.

Password (ENABLE/DISABLE) Parameter

This parameter lets you enable or disable the password parameter. The default for this parameter is ENABLE. See Chapter 7 for more information on passwords.

CPU ID Parameters ID1, ID2, and ID3

The next PLC parameter you can configure is CPU ID parameter ID1. This parameter is the first of three consecutive parameters used to input a network identification name on a Series 90 protocol network.

Each parameter is a 4-digit hexadecimal number. The four hexadecimal digits correspond to two ASCII characters; thus, a 6-character identifier is entered two characters at a time. If the total identifier consists of less than six characters, all trailing characters must be set to the NULL character (ASCII 00H). By default, the PLC is not assigned a network name; all characters are set to NULL.

Use the Right cursor key to scroll through the PLC parameters until the first ID parameter is displayed. Enter the key sequence of the ASCII-hex numbers which correspond to the network name you wish to specify. Then, press the ENT key. Follow this same procedure for parameters ID2 and ID3.

This parameter has three inputs ID1, ID2, ID3 which combine together to form a 6 character ASCII word which gives this CPU a unique identification value. This value is used to identify this CPU when it is connected to a communications bus network which has more than one CPU connected on the network.

Assume that the network name *ABCDE* is to be assigned to the PLC. This name corresponds to the ASCII-HEX sequence 41-42-43-44-45-00.

- ID1 = 4142 which equals AB
- ID2 = 4344 which equals CD
- ID3 = 45-00 which equals E

Also assume that the previous parameter, MODEM TURNAROUND TIME, is currently being viewed. Press the \rightarrow key two times to select the ID1 parameter.

Initial display:

RO:01	PLC	<S
MDM TAT:	0	

Press the

\rightarrow

 key two times:

RO:01	PLC	<S
ID1:	0000H	

Press the key sequence

4

1

4

2

 :

RO:01	PLC	<S
ID1:	4142_H	

Press the  key:

RO:01 PLC <S
ID1: 4142_H

Press the  key:

RO:01 PLC <S
ID2: 0000H

Press the key sequence     :

RO:01 PLC <S
ID1: 4344_H

Press the  key:

RO:01 PLC <S
ID2: 4344_H

Press the  key:

RO:01 PLC <S
ID3: 0000H

Press the key sequence     :

RO:01 PLC <S
ID3: 4500_H

Press the  key:

RO:01 PLC <S
ID3: 4500_H

Default I/O

The default I/O parameter allows you to view and change the current state of the default I/O configuration function. The following example shows the key sequences and resulting screens to view or edit this parameter. You can request that the PLC reconfigure the I/O based on the default I/O configuration (refer to Chapter 4, *Reconfiguration* for details. Refer to Table 5-3 for a list of the default I/O configuration.

Initial display:

RO:01 PLC <S
ID3:0000H

Press the  key two times:

```
RO:01  PLC  <S
DEF I/O: ENABLE
```

Press the  key:

```
RO:01  PLC  <S
DEF I/O: DISABLE
```

Note that on the previous display, the word **DISABLE** will be flashing to signify that you have initiated a change to the current value of the configuration parameter. Also, because of the ramifications of changing the value of this parameter, you will be prompted to confirm the change. This confirmation display is shown below.

Press the  key:

```
RO:01  PLC  <S
<ENT>=Y <CLR>=N
```

At this point you can either confirm or cancel the change to the default I/O configuration parameter. If the change is confirmed and the value of the parameter has been changed from **DISABLE** to **ENABLE**, all I/O modules will be reconfigured as shown in Table 4-3. Note that all smart I/O modules, such as the HSC and GCM, will be dropped from the configuration since they are not included in the default configuration. The slots that these modules occupied will now be shown as **EMPTY** on the HHP. The PCM is reconfigured to the default configuration.

If the change is confirmed and the value of the parameters has been changed from **ENABLE** to **DISABLE**, no changes occur to the existing configuration. However, as new I/O modules are detected at power-up in slots that were previously **EMPTY**, they will not be configured automatically by the PLC.

Since the previous method of enabling and disabling the default I/O configuration is still possible (along with this configuration parameter) it is possible for the value of this parameter to change indirectly. For example, if the value of this parameter is **DISABLE** and the key sequence #, -/+, 9, DEL is pressed while in configuration mode, the value of this parameter would then become **ENABLE**. Conversely, if you were to disable the default I/O configuration by manually changing the reference offset of an I/O module, the value of this parameter would become **DISABLE**. Thus, changing this parameter's value from **DISABLE** to **ENABLE** would have the same effect as using the previous key sequence.

When configuration is read from MEM card or EEPROM, or STOREd from Logicmaster 90-30 and this configuration has **DEFAULT CONFIG** enabled, the I/O will be auto-configured but the CPU parameters will be set to the value that they have in the configuration being read into the PLC.

When configuration is verified with a MEM card or EEPROM and the configuration on the device has **DEFAULT I/O** enabled, the verify will *always* be successful.

When configuration is verified with Logicmaster 90-30 and the configuration on Logicmaster 90-30 has **DEFAULT CONFIG** enabled, the results of the verify will be determined by the value of the checksums. This means that a configuration that will

verify may not produce the same results if STOREd, since modules may have been physically added since the Logicmaster 90-30 configuration was LOAded from the PLC

Checksum Words Per Sweep

This parameter allows you to select the number of words per sweep to be checksummed. The selectable range is from 8 to 32 words (any number of words between 8 and 32).

Canceling a Configuration Operation

The CLR key can be used to cancel the current parameter modification and restore the original setting. When attempting to change the configuration of a PLC parameter, a valid value must be entered. If an invalid value is specified, the configuration request will be refused and a *DAT ERR* message will be displayed.

In a GOTO operation, described in the beginning of this chapter, the CLR key can be used to cancel the operation and remain on the currently viewed slot. If a slot number has already been entered, press the CLR key to erase the current input and remain in slot selection mode. Pressing the CLR key a second time cancels the GOTO operation. If no user input had been specified when the CLR key is pressed the first time, only a single press of the CLR key is required to cancel the GOTO operation.

Exiting Configuration Mode

To exit the PLC configuration function, press the MODE key. The mode selection screen will be displayed.

Chapter 4

Series 90 Micro PLC Configuration

The Series 90 Micro PLC can be configured and programmed using the Series 90-30/20/MicroHand-HeldProgrammer (IC693PRG300).

Configuration and programming using the Hand-Held Programmer must be done with the Hand-Held Programmer (HHP) attached to and interfacing with the PLC.

This chapter has two Sections. Section 1 describes configuration of the Micro PLC CPU parameters; Section 2 describes configuration of the High Speed Counter that is built into the Micro PLC.

For detailed information about the Series 90 Micro PLC, refer to GFK-1065, the *Series 90 Micro PLC User's Manual*.

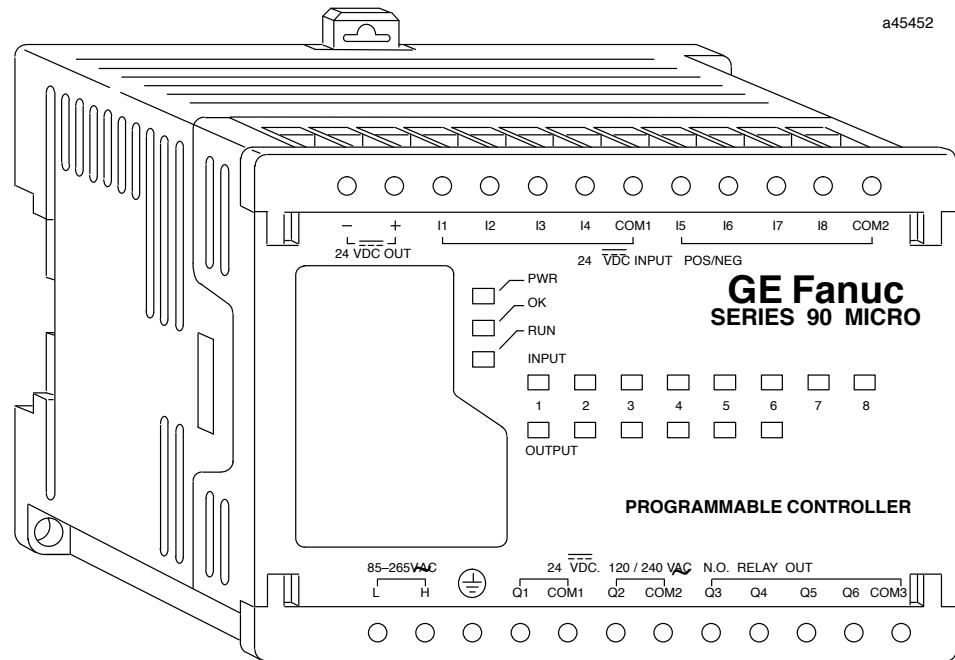

Figure 4-1. Series 90 Micro Programmable Logic Controller

Section 1: Micro PLC Configuration

Table 4-1 lists all parameters for the Micro PLC except those concerning the High Speed Counters (see Section 2 for details on configuring the High Speed Counters). Parameters that are displayed for the user's information only are denoted **not editable** in the description.

Table 4-1. Micro PLC Parameters

Parameter	Description	Possible Values	Default Value
I/Oscan-Stop	Determines whether I/O is to be scanned while the PLC is in STOP mode	YES NO	NO
Pwr Up Mode	Selects power up mode.	LAST STOP RUN	LAST
LogicFrom	Source of logic when the PLC is powered up	RAM PROM (flash memory)	RAM
Registers	Selects source of register data when the PLC is powered up.	RAM PROM (flash memory)	RAM
Passwords	Determines whether the password feature is enabled or disabled. (Note: If passwords are disabled, the only way to re-enable them is to clear the Micro PLC memory by power cycling the unit with the battery removed.)	ENABLED DISABLED	ENABLED
Baud Rate	Data transmission rate (in bits per second)	300 4800 600 9600 1200 19200 2400	19200
Data Bits	Determines whether the CPU recognizes 7-bit or 8-bit words	7 8	8
Parity	Determines whether parity is added to words	ODD EVEN NONE	ODD
Stop Bits	Number of stop bits used in transmission. (Most serial devices use one stop bit; slower devices use two.)	1 2	1
Modem TT	Selects modem turnaround time (time required for the modem to start data transmission after receiving the transmitrequest)	0-255	0
Idle Time	Time (in seconds) the CPU waits for the next message to be received from the programming device before it assumes that the programming device has failed and proceeds to its base state	1-60	10
Sweep Mode	Normal - the sweep runs until it is complete Constant - the sweep runs for the time specified in Sweep Tmr	NORMAL CNST	NORMAL
Sweep Tmr	Constant sweep time (in milliseconds). Editable when Sweep Mode is CNST; non-editable otherwise.	NORMALmode-N / A CNST mode - 5-200	N / A 100

Table 4-1. Micro PLC Parameters (continued)

Parameter	Description	Possible Values	Default Value
In RefAddr	Discrete input reference	%I00001 noteditable	%I00001
Input Size	Discrete input size	8 noteditable	8
Out RefAddr	Discrete output reference	%Q00001	%Q00001
Output Size	Discrete output size	6	6

The HHP is used to develop, debug, and monitor ladder logic programs, and to monitor data tables. You can use the HHP to perform the following tasks:

- Statement List logic program development, including insert, edit, and delete functions. The Statement List programming instructions provide basic (boolean) instructions to execute logical operations such as AND and OR, and many functions to execute advanced operations including arithmetic operations, data conversion, and data transfer.
- On-line program changes
- Search logic programs for instructions and/or specific references
- Monitor reference data while viewing logic program
- Monitor reference data in table form in binary, hexadecimal, or decimal formats
- Monitor timer and counter values
- View PLC scan time, firmware revision code and current logic memory use
- Load, store, and verify program logic and configuration between the Hand-Held Programmer and a removable Memory Card (IC693ACC303) which allows programs to be moved between PLCs or loaded into multiple PLCs
- Start or stop the PLC from any mode of operation

Note

Unlike other Series 90-30/20 models, the Series 90 Micro PLC requires that, after a program has been edited, you save the program to the user program in non-volatile flash memory. Refer to *Storing the User Program Using the HHP* on page 4-6 for the required procedure for saving programs when a Micro PLC program is modified in any way (create, edit, insert, etc.).

HHP Configuration Screens

1. The following screen (Main Menu) will be displayed on the Hand-Held Programmer after the Series 90 Micro PLC has successfully completed its power-up sequence.

```

1. PROGRAM <S
2. DATA

```

This screen allows you to select the mode of operation of the program. The choices are: *PROGRAM*, *DATA*, *PROTECT* and *CONFIG* (Configuration). You can see the other choices by pressing the UP and DOWN arrow keys. Each choice has a number in front of it which is used to select the desired mode.

2. Enter the configuration mode by pressing the **4** key then the **ENT** key from the Main Menu screen.

The up and down cursor keys allow you to move between power supply configuration, CPU configuration, Input configuration, Output configuration, and HSC configuration. The left and right arrows allow selection of parameters within each of the configurations.



This screen indicates that the CPU function is located in rack 0 and slot 01 (R01:01). For compatibility with Series 90-30 PLCs, the different functions mimic the rack and slot locations. The Series 90 Micro PLC system is always in rack 0. The following table shows the fixed slot assignments for the different functions of the 14-point Micro PLC.

Slot	Function	Fixed/Configurable
0	PowerSupply	Fixed
1	CPU Parameters	Configurable
2	InputLocations	Fixed: %I1 to %I8
3	OutputLocations	Fixed: %Q1 to %Q6
4	High Speed Counter	Fixed:I00497-I00512 Q00497-Q00512 AI00001-AI000015

If you want to transfer a program developed for a Series 90 Micro PLC to a Series 90-30 PLC, the I/O modules in the Series 90-30 PLC must be in the above listed rack and slot locations for the program and configuration to work properly.

The screen shown above also shows the first configuration item which allows you to change the Hand-Held Programmer Key Click feature. The default is KEY CLK: OFF.

3. Pressing the up arrow key causes the next screen to be displayed:

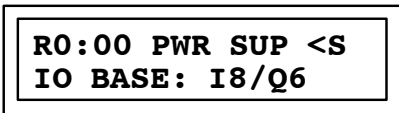

This screen indicates that the baseplate located at rack 0 and slot 00 is a generic 8 Input/6Output module.

4. Pressing the down arrow key causes the previous screen to be displayed:



Use the left and right arrow keys to view the other Micro PLC parameters for configuration and the **-/+** key to select the items within each parameter. Refer to Table 4-1 for acceptable values and default values for Micro PLC parameters.

- When all Micro PLC parameters have been configured, press the down arrow key again to cause the input screen to be displayed (this is not configurable):

```
R0:02 I <S  
I16:I0001-I0008
```

If the program is transferred to a Series 90-30 Model 311, Model 313, Model 331, Model 340, Model 341, or Model 351, the input module should be located in the first I/O slot (slot 02 on the Model 331, Model 340, Model 341 and Model 351, and slot 01 on the Model 311 and Model 313).

- Pressing the down arrow key again causes the output screen to be displayed (this is not configurable):

```
R0:03 Q <S  
Q16:Q0001-Q0006
```

If the program is transferred to a Series 90-30 Model 311, Model 313, Model 331, Model 340, Model 341, or Model 351, the output module should be located in the second I/O slot (slot 03 on the Model 331, Model 340, Model 341, and Model 351, and slot 02 on the Model 311 and Model 313).

- Pressing the down arrow key again causes the first HSC screen to be displayed:

```
R0:04 HSC <S  
I16:I0497-I0512
```

If the program is transferred to a Series 90-30 Model 311, Model 313, Model 331, Model 340, Model 341, or Model 351 the HSC module should be located in the third I/O slot (slot 04 on the Model 331, Model 340, Model 341, and Model 351, and slot 03 on the Model 311 and Model 313).

The complete HSC configuration screens are discussed in Section 2..

Storing the User Program Using the HHP

Unlike other Series 90-30 PLC models or the Series 90-20 PLC, the Series 90 Micro PLC requires that, after a program has been edited, you save the program to the user program in non-volatile flash memory. To do this, perform the following steps.

1. With the HHP showing a screen that resembles the following, press the **WRITE** key.

```
#XXXX          <S  
<END OF PROGRAM>
```

The following screen will result:

```
WRITE MEM CARD<S  
PRG CFG REG
```

2. Next press the **-/+** key twice. The following screen will appear:

```
WRITE USR PRG <S  
ONLY
```

3. Finally, press the **ENT** key. This will store the user program. Note that this may take about a minute. When the program has been stored, the following screen will be displayed:

```
WRITE OK          <S
```

At this point the program can be put into RUN mode.

4. To return to the program edit mode, press the **ENT** key.

The above procedure should be used any time that a Micro PLC program is modified in any way (create, edit, insert, and so forth).

Section 2: High Speed Counter Configuration

If you have just configured the Series 90 Micro PLC parameters using the Hand-Held Programmer (see Section 1) all you need to do to select the High Speed Counter is use the Down Arrow key [↓] to sequence to the slot assigned to the High Speed Counter. Press the **READ** key, then the **ENT** key.

Note

The Series 90 Micro PLC functions are assigned to rack and slot locations corresponding to those in the Series 90-30 PLCs. The Series 90 Micro PLC system is always in rack 0, and the its HSC functions are in slot 4.

When the Series 90 Micro PLC first powers up, it has default values for all of the HSC parameters. To meet the requirements of most applications, the High Speed Counters will have to be configured before they can be used.

Parameter Definitions

Tables 4-2 through 4-4 list all the configuration parameters in the Series 90 Micro PLC High Speed Counter function and the abbreviations for those parameters as they are displayed on the Hand-Held Programmer. Note that parameters 1 through 4 are common to both A and B-type counters. Definitions for each parameter are provided on pages 4-11 through 4-15. For detailed information on operation of the Series 90 Micro PLC High Speed Counter function, see GFK-1065, the *Series 90 Micro PLC User's Manual*.

Table 4-2. Common Parameter Abbreviations

Parameter	HHP Screen Number	HHP Abbreviation	Value 1	Value 2	Value 3	Default
Counter Type	1	CNTRTYPE	ALLA	B1-3/A4	-	ALLA
Output Failure Mode	2	FAILMODE	NORMAL	FRCOFF	HOLD	NORMAL

Table 4-3. Abbreviations for All Type A Counter Configuration

Parameter	HHP Screen Number	HHP Abbreviation	Value 1	Value 2	Default
Counter1 Enable/Disable	3	CTR1	ENABLE	DISABLE	DISABLE
Counter1 Output Enable/Disable	4	CTR1 OUT	ENABLE	DISABLE	DISABLE
Counter 1 Direction	5	CTR1 DIR	UP	DOWN	UP
Counter 1 Mode	6	CTR1 MODE	CONT	1 SHOT	CONT
Counter 1 Preload/Strobeselection	7	CTR1	PRELOAD	STROBE	PRELOAD
Counter 1 Strobe Edge	8	STBEDGE1	POS	NEG	POS
Counter 1 Count Edge	9	CNT1 EDGE	POS	NEG	POS
Time Base 1	10	TIME BS 1	-	-	1000mS
High Limit 1	11	HI LIM 1	-	-	+32767
Low Limit 1	12	LO LIM 1	-	-	0
ON Preset 1	13	ON PST 1	-	-	+32767
OFF Preset 1	14	OFF PST1	-	-	0
Preload 1	15	PRELD 1	-	-	0
Counter 1 PWM Output Enable/Disable*	16	PWMOUT1	ENABLE	DISABLE	DISABLE
Counter 1 PulseOutputEnable/Disable*	17	PULSEOUT1	ENABLE	DISABLE	DISABLE
Counter2 Enable/Disable	18	CTR2	ENABLE	DISABLE	DISABLE
Counter2 Output Enable/Disable	19	CTR2 OUT	ENABLE	DISABLE	DISABLE
Counter 2 Direction	20	CTR2 DIR	UP	DOWN	UP
Counter 2 Mode	21	CTR2 MODE	CONT	1 SHOT	CONT
Counter 2 Preload/Strobeselection	22	CTR2	PRELOAD	STROBE	PRELOAD
Counter 2 Strobe Edge	23	STBEDGE2	POS	NEG	POS
Counter 2 Count Edge	24	CNT2EDGE	POS	NEG	POS
Time Base 2	25	TIME BS 2	-	-	1000mS
High Limit 2	26	HI LIM 2	-	-	+32767
Low Limit 2	27	LO LIM 2	-	-	0
ON Preset 2	28	ON PST 2	-	-	+32767
OFF Preset 2	29	OFF PST2	-	-	0
Preload 2	30	PRELD2	-	-	0
Counter2 PWM Output Enable/Disable*	31	PWMOUT2	ENABLE	DISABLE	DISABLE
Counter 2 PulseOutputEnable/Disable*	32	PULSEOUT2	ENABLE	DISABLE	DISABLE

*These parameters apply only to DC IN/DC OUT type Series 90 Micro PLCs.

Table 4-3. Abbreviations for All Type A Counter Configuration - continued

Parameter	HHP Screen Number	HHP Abbreviation	Value 1	Value 2	Default
Counter3 Enable/Disable	33	CTR3	ENABLE	DISABLE	DISABLE
Counter3 Output Enable/Disable	34	CTR3OUT	ENABLE	DISABLE	DISABLE
Counter 3 Direction	35	CTR3DIR	UP	DOWN	UP
Counter 3 Mode	36	CTR3MODE	CONT	1 SHOT	CONT
Counter 3 Preload/Strobe selection	37	CTR3	PRELOAD	STROBE	PRELOAD
Counter 3 Strobe Edge	38	STBEDGE3	POS	NEG	POS
Counter 3 Count Edge	39	CNT3EDGE	POS	NEG	POS
Time Base 3	40	TIME BS 3	-	-	1000mS
High Limit 3	41	HI LIM 3	-	-	+32767
Low Limit 3	42	LO LIM 3	-	-	0
ON Preset 3	43	ON PST 3	-	-	+32767
OFF Preset 3	44	OFF PST3	-	-	0
Preload 3	45	PRELD3	-	-	0
Counter 3 PWM Output Enable/Disable*	46	PWMOUT3	ENABLE	DISABLE	DISABLE
Counter 3 Pulse Output Enable/Disable*	47	PULSEOUT3	ENABLE	DISABLE	DISABLE
Counter4 Enable/Disable	48	CTR4	ENABLE	DISABLE	DISABLE
Counter4 Output Enable/Disable	49	CTR4OUT	ENABLE	DISABLE	DISABLE
Counter 4 Direction	50	CTR4DIR	UP	DOWN	UP
Counter 4 Mode	51	CTR4MODE	CONT	1 SHOT	CONT
Counter 4 Preload/Strobe selection	52	CTR4	PRELOAD	STROBE	PRELOAD
Counter 4 Strobe Edge	53	STBEDGE4	POS	NEG	POS
Counter 4 Count Edge	54	CNT4EDGE	POS	NEG	POS
Time Base 4	55	TIME BS 4	-	-	1000
High Limit 4	56	HI LIM 4	-	-	+32767
Low Limit 4	57	LO LIM 4	-	-	0
ON Preset 4	58	ON PST 4	-	-	+32767
OFF Preset 4	59	OFF PST4	-	-	0
Preload 4	60	PRELD4	-	-	0
Counter4 PWM Output Enable/Disable*	61	PWMOUT4	ENABLE	DISABLE	DISABLE

*These parameters apply only to DC IN/DC OUT type Series 90 Micro PLCs.

Table 4-4. Abbreviations for Type B1-3/A4 Counter Configuration

Parameter	HHP Screen Number	HHP Abbreviation	Value 1	Value 2	Default
Counter 1 Enable/Disable	3	CTR1	ENABLE	DISABLE	DISABLE
Counter 1 Output Enable/Disable	4	CTR1OUT	ENABLE	DISABLE	DISABLE
Counter 1 Direction	5	CTR1DIR	UP	DOWN	UP
Counter 1 Mode	6	CTR1MODE	CONT	1 SHOT	CONT
Counter 1 Preload/Strobe selection	7	CTR1	PRELOAD	STROBE	PRELOAD
Counter 1 Strobe Edge	8	STBEDGE1	POS	NEG	POS
Counter 1 Count Edge	9	CNT1EDGE	POS	NEG	POS
Time Base 1	10	TIME BS 1	-	-	1000mS
High Limit 1	11	HI LIM 1	-	-	+32767
Low Limit 1	12	LO LIM 1	-	-	0
ON Preset 1	13	ON PST 1	-	-	+32767
OFF Preset 1	14	OFF PST1	-	-	0
Preload 1	15	PRELD1	-	-	0
Counter 4 Enable/Disable	16	CTR4	ENABLE	DISABLE	DISABLE
Counter 4 Output Enable/Disable	17	CTR4OUT	ENABLE	DISABLE	DISABLE
Counter 4 Direction	18	CTR4DIR	UP	DOWN	UP
Counter 4 Mode	19	CTR4MODE	CONT	1 SHOT	CONT
Counter 4 Preload/Strobe selection	20	CTR4	PRELOAD	STROBE	PRELOAD
Counter 4 Strobe Edge	21	STBEDGE4	POS	NEG	POS
Counter 4 Count Edge	22	CNT4EDGE	POS	NEG	POS
Time Base 4	23	TIME BS 4	-	-	1000
High Limit 4	24	HI LIM 4	-	-	+32767
Low Limit 4	25	LO LIM 4	-	-	0
ON Preset 4	26	ON PST 4	-	-	+32767
OFF Preset 4	27	OFF PST4	-	-	0
Preload 4	28	PRELD4	-	-	0
Counter 4 PWM Output Enable/Disable*	29	PWMOUT4	ENABLE	DISABLE	DISABLE

*These parameters apply only to DC IN/DC OUT type Series 90 Micro PLCs.

Note

Counter 1 is an A-QUAD-B type counter and counter 4 is an A type counter.

Counter Type

This parameter specifies the counter configuration type. **A4** selects four identical, independent (Type A) counters. **B1-3, A4** selects one Type B counter (for A-Quad-B counting) and one Type A counter.

Output Failure Mode

If the module detects a loss of the CPU, it can respond in three different ways:

- it can continue to operate normally, processing the inputs and controlling the outputs according to its configuration (NORMAL);
- it can force all four outputs to turn off (FRCOFF);
- the module can hold the outputs at the current state (HOLD).

These responses remain in effect until the CPU returns to operation or the module is power-cycled.

Counter Direction

Each counter can be configured to count either up or down. The default is Up.

Counter Mode

Each counter on a module has programmable count limits that define its range. The counter can either count continuously within these limits, or count to either limit, then stop.

Continuous Counting

In the continuous counting mode, if either the upper or lower limit is exceeded, the counter wraps around to the other limit and continues counting. Continuous counting is the default mode.

Single-Shot Counting

If single-shot counting is selected, the counter will count to its upper or lower limit, then stop. When the counter is at the limit, counts in the opposite direction will count it back off the limit. The Accumulator can also be changed by loading a new value from the CPU or by applying a Preset Input.

Note

In either the single-shot or continuous mode, the counter stops at 1 past the limit (that is, at $n+1$ if n is the high limit, and $n-1$ if n is the low limit). Therefore, where N is the desired number of pulses to be counted, you must configure the counter so that $\text{high limit} = N-1$, or $\text{low limit} = N+1$.

Strobe Edge

Strobe inputs are edge sensitive. Each Strobe input on the module can be individually configured to have either the positive or the negative edge active. By default, they are positive-edge sensitive.

Counter Timebase

For each counter, the timebase represents a span of time which can be used to measure the rate of counting. For example, the program may be required to monitor the number of count pulses which are occurring every 30 seconds.

A timebase from 1 msec to 65535 msec can be selected for each counter. The counter timebase is set to 1 second (1000 msec) by default. The module stores the number of counts that occurred during the last-completed timebase interval in the Counts/Timebase register. The range of the Counts/Timebase register is -32768 and $+32767$ counts. The timebase value selected should not allow the Counts/Timebase register to overflow at the maximum count frequency. If it does, the sign of the Counts/Timebase will change from (+) to (-) or (-) to (+).

Count Limits

Each counter can be assigned upper and lower count limits. All Accumulator preload values and output on/off preset values must lie within these limits. The upper (high) limit is the most positive, and the lower limit is the most negative. Both can be positive, or both can be negative, but the high limit is always greater than the low limit.

If the Accumulator value is outside the new limits when the limits are changed it is automatically adjusted to the low limit value. If the new limits are incompatible, that is, ($\text{high} < \text{low}$ or $\text{low} > \text{high}$), then they will be rejected and the old limits retained. In this case a counter limit error code will be returned. To avoid this situation when the limits are changed one at a time, a good rule to follow is: always move the high limit first when shifting the limits up and always move the low limit first when shifting them down.

The limit range for both Type A and Type B counters is $-32,768$ to $+32,767$.

Output Preset Positions

Each counter output has a preset ON and OFF position. The output state indicates when the counter accumulator value is between the ON and OFF points.

If the output is enabled for the HSC channel being used, the output will turn on in accordance with the following table:

Preset closest to low limit	Output ON	Output OFF
ON	> ON Preset < = OFF Preset	> OFF Preset < = ON Preset
OFF	< = OFF Preset > ON Preset	< = ON Preset > OFF Preset

The output may be either on or off when the accumulator value lies between the Preset points.

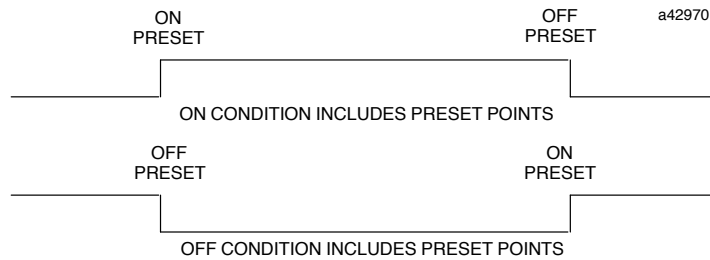

For example:

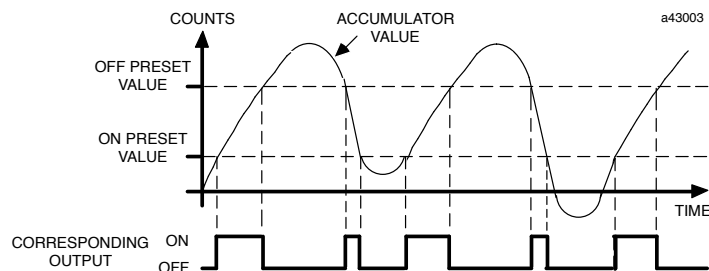

Location of Preset Points

The Preset points may be located anywhere within the counter range. When the accumulator value is between the Preset points, the output ON/OFF state will always be that of the lowest (most negative) Preset point. When the accumulator value is *not* between the Preset points, the output ON/OFF state will be that of the most positive preset. This is true regardless of the counter direction.

The following example compares the output state and accumulator value of a 16-bit counter.

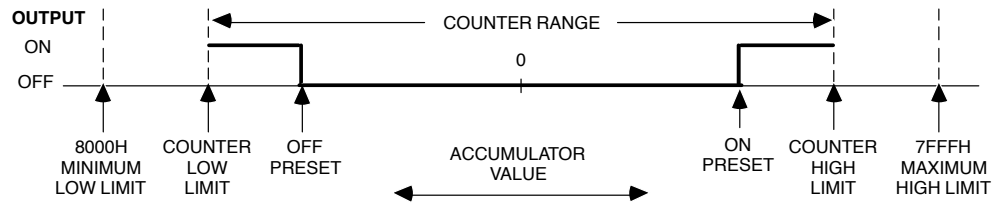

If both preset points are within the counter range, the output always switches at the Preset points. If only one of the Preset points is programmed within the counter range, then the counter limits will function as the other Preset point. In the continuous mode, the output will switch when wraparound occurs.

If neither of the Preset points is in the counter range then the output state will not change; it will always be the state of the most positive Preset. If both Preset points are equal and out of range, the output will always be OFF. If both Preset points are equal and within the counter range, then the output will only be on for one count value - as defined by the Preset points.

Preload Value

For each counter, a starting count value can be specified which will be used when the Preload input is activated. If the counter should be reset to 0, enter 0 as the Preload value. (The default value is 0.)

Configuration Screens Common to both Counter Types (ALL A and B1-3, A4)

Note

Screen numbers correspond to parameter numbers listed in Tables 4-2 through 4-4.

Screen 1 - Counter Type

```
RO:04 HSC    <S
CNTR TYPE:ALL A
```

This screen allows you to select the counter type. Press the -/+ key to select the type of counter you desire, then press the ENT key. The CLR key (before enter is pressed) will cancel the operation.

Screen 2 - Output Default/Module Failure Mode

```
RO:04 HSC    <S
FAIL MODE:NORMAL
```

This screen selects the state that the outputs assume if communications with the PLC is lost. NORMAL indicates that the outputs will continue to operate under control of the counter. FRCOFF causes the outputs to be forced off if communications is lost, while HOLD causes the High Speed Counter to retain the last state that the output points held before communication was lost.

A4 Counter Specific Screens

The following screens will be displayed when **ALL A** is selected in Screen 1.

Screens 8, 23, 38, 53 - Strobe Edge

```

RO:04 HSC Vx.x <S
CTRx STB:POS

```

These screens configure the strobe input edge to trigger on a positive or negative going signal.

Screens 9, 24, 39, 54 - Counter Strobe Edges

```

RO:04 HSC Vx.x <S
STB EDGE x:POS

```

This configuration selects whether the strobe edge will trigger on a positive-going or negative-going signal.

Screens 3, 18, 33, 48 - Counter Enable

```

RO:04 HSC <S
CTRx :DISABLE

```

This series of four screens enables or disables the specified counter. This means that, for each counter enabled, it will use certain portions of PLC reference memory and PLC input and output resources. If CTR1 is set to ENABLE, screens 4 through 15 will appear (or 19 through 30 for counter number 2, 34 through 45 for counter number 3, and 49 through 60 for counter number 4).

Note

If the configured Series 90 Micro PLC is a DC IN/DC OUT type, this screen will only appear if the PWM OUT_x option and the PULSE OUT_x option for the same channel are disabled. (see screens 16 and 17 below)

Screens 4, 19, 34, 49 - Count Output Enable

```

RO:04 HSC <S
CTRx OUT:ENABLE

```

Screens 5, 20, 35, 50 - Counter Direction

```

R0:04 HSC      <S
CTRx DIR:UP

```

This series of three screens is used to set the count direction.

Screens 6, 21, 36, 51 - Counter Mode

```

R0:04 HSC      <S
CTRx MODE:CONT

```

These screens specify the Counter Mode-continuous or one-shot.

Screens 7, 22, 37, 52 - Counter Strobe/Preload Selection

```

R0:04 HSC      <S
CTRx :PRELOAD

```

This series of screens is used to select PRELOAD or STROBE type counting for Counters 1-4.

Screens 8, 23, 38, 53 - Strobe Edge

```

R0:04 HSC      <S
STB EDGEx :POS

```

These screens configure the strobe input edge to trigger on a positive or negative-going signal.

Screens 9, 24, 39, 54 - Counter Edge

```

R0:04 HSC      <S
CTRx EDGE: POS

```

These screens configure the counter input edge to trigger on a positive or negative going signal.

Screens 10, 25, 40, 55 - Time Base Value

```

R0:04 HSC      <S
TIME BS x: 1000

```

These screens allow you to enter the time base that is used in the Counts Per Time Base calculation. The default is 1000 milliseconds (1 second). To change the time base, select the value using the numeric keys on the Hand-Held Programmer then press the ENT key to record the value.

Screens 11, 26, 41, 56 - High Limit

```
RO:04 HSC    <S  
HI LIM x: 32767
```

These screens are used to specify the highest (most positive) value the count accumulator can reach. The default is 32767, which is the maximum value the Type A counters can handle. As with the time base, use the Hand-Held Programmer numeric keys to change the value, then press the **ENT** key to record it. Pressing **CLR** instead of **ENT** cancels the entry.

Screens 12, 27, 42, 57 - Low Limit

```
RO:04 HSC    <S  
LO LIM x: 0
```

These screens specify the lowest (most negative) value for the count accumulator.

Screens 13, 28, 43, 58 - ON Preset Value

```
RO:04 HSC    <S  
ON PST x: 32767
```

When the counter accumulator exceeds this value (depending also on the value of the OFF preset) the associated output is turned on (depending on the state, either enabled or disabled, of the output control flags in the %Q data word). For details, see "Output Preset Positions" on page 6-22.

Screens 14, 29, 44, 59 - OFF Preset Value

```
RO:04 HSC    <S  
OFF PST x: 0
```

When the counter accumulator exceeds this value, the associated output is turned off.

Screens 15, 30, 45, 60 - Preload Value

```
RO:04 HSC    <S  
PRELD x: 0
```

This parameter specifies the value that will be loaded into the accumulator when the associated PRELOAD input on the terminal strip is asserted.

The following two screens will only be seen if the Series 90 Micro PLC model is a DC IN/DC OUT unit.

Screens 16, 31, 46, 61 - PWM Output

This option can only be enabled if the CTRx option and the PULSE OUTx option for the same channel are disabled.

```
RO:04 HSC      <S
PWMOUTx: DISABLE
```

These screens select pulse width modulation (PWM) as the counter output.

Screens 17, 32, 47 - Pulse Output

This option can only be enabled if the CTRx option and the PWM OUTx option for the same channel are disabled.

```
RO:04 HSC      <S
PLSOUTx: DISABLE
```

These screens select a pulse signal as the counter output.

Note

The PULSE OUT option will only be available on counter channels 1-3.

Type B Counter Specific Screens

The following screens are specific to B1-3/A4 counters and are displayed when B1-3/A4 is selected as the counter type in Screen 1. In this type of configuration, counter 1 is the A-Quad-B and counter 4 is the A-type counter.

Screens 3, 18 - Counter Enable

```

RO:04 HSC <S
CTRx :DISABLE

```

This series of two screens enables or disables a specified counter. This means that each counter enabled will use certain portions of PLC reference memory and PLC input and output resources. Only one set of the two screens is shown here. All of the other counters are configured in the same manner, except that the counter number is different. Note that if CTR1 is set to ENABLE then screens 4-15 will appear (or 19-30 for counter number 4).

Note

If the configured Series 90 Micro PLC is a DC IN/DC OUT type, this screen will appear only for the type A counter (channel 4) if the PWM OUT4 option is disabled. (see screen 29)

Screens 4, 19 - Count Output Enable

```

RO:04 HSC <S
CTRx OUT:ENABLE

```

This series of three screens is used to set the counter output enable,

Screens 6, 20 - Counter Strobe/Preload Selection

```

RO:04 HSC <S
CTRx :PRELOAD

```

This series of three screens is used to set the counters as PRELOAD or STROBE type counting.

Screens 8, 21 - Strobe Edge

```

RO:04 HSC <S
STB EDGEx :POS

```

These screens configure the strobe input edge to trigger on a positive or negative-going signal.

Screens 9, 22 - Counter Edge

```

RO:04 HSC      <S
CTRx EDGE: POS

```

These screens configure the counter input edge to trigger on a positive or negative-going signal.

Screens 10, 23 - Time Base Value

```

RO:04 HSC      <S
TIME BS x: 1000

```

These screens allow you to enter the time base that is used in the the Counts Per Time Base calculation. The default is 1000 milliseconds (1 second). To to change the time base, select the value using the numeric keys on the Hand-Held Programmer, and then press the ENT key to record the value.

Screens 11, 24 - High Limit

```

RO:04 HSC      <S
HI LIM x: 32767

```

These screens are used to specify the highest (most positive) value of the count accumulator. The default is 32767, which is the maximum value the Type A counters can handle. As with the time base, use the Hand-Held Programmer numeric keys to change the value, then press the ENT key to record it. Pressing CLR instead of ENT cancels the entry.

Screens 12, 25 - Low Limit

```

RO:04 HSC      <S
LO LIM x: 0

```

These screens specify the lowest (most negative) value for the count accumulator.

Screens 13, 26 - ON Preset Value

```

RO:04 HSC      <S
ON PST x: 32767

```

When the counter accumulator reaches this value (depending also on the value of the OFF preset) the associated output is turned on (depending on the state, either enabled or disabled, of the output control flags in the %Q data word).

Screens 14, 27 - OFF Preset Value

```
RO:04 HSC      <S  
OFF PST x: 0
```

This value is used in conjunction with the ON preset to indicate the accumulator value at which the associated output point will be turned off.

Screens 15, 28 - Preload Value

```
RO:04 HSC      <S  
PRELD x: 0
```

This parameter specifies the value that will be loaded into the accumulator when the associated PRELOAD input on the terminal strip is asserted.

Screen 29 - PWM Output

```
RO:04 HSC      <S  
PWM OUT4: DISBL
```

This screen selects PWM (pulse width modulation) as the counter 4 output. Note that this option can only be enabled if CTR is set to DISABLE *and* the configured Series 90 Micro PLC is a DC IN/DC OUT model.

Chapter 5

I/O Configuration

The left slot in a Series 90-30 PLC rack always contains the power supply. Model 311 and 313 CPUs are embedded in the backplane in 5 and 10-slot baseplates. Model 331, 340, 341, and 351 CPU modules are always located in slot 1 of rack 0 (for configuration purposes, the 211 CPU is in slot 1 of rack 0). Model 331, 340, 341, and 351 CPU and expansion baseplates are available in 5 and 10-slot versions. Slots for I/O modules are referenced as slots 1 to 5 for the Model 311/313 5-slot baseplates; slots 1 to 10 for the Model 323 10-slot baseplate; slots 2 to 10 (or 2 to 5) for the Model 331/340/341/351 CPU baseplate; and slots 1 to 10 (or 1 to 5) for Model 331/340/341/351 expansion baseplates. An example of a 5 and a 10-slot Series 90-30 PLC Model 311 or 313 is shown in the following figure (Models 311 and 313 appear physically the same).

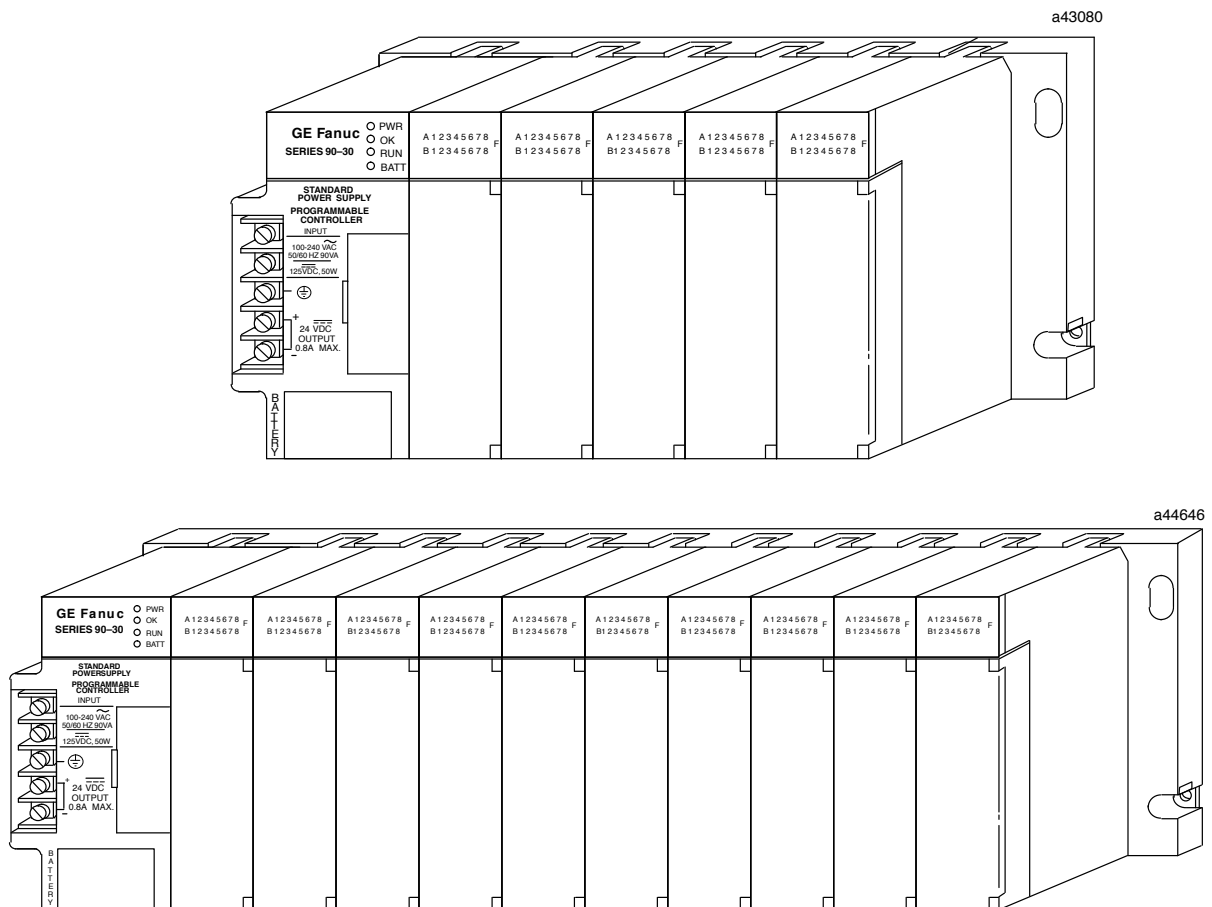
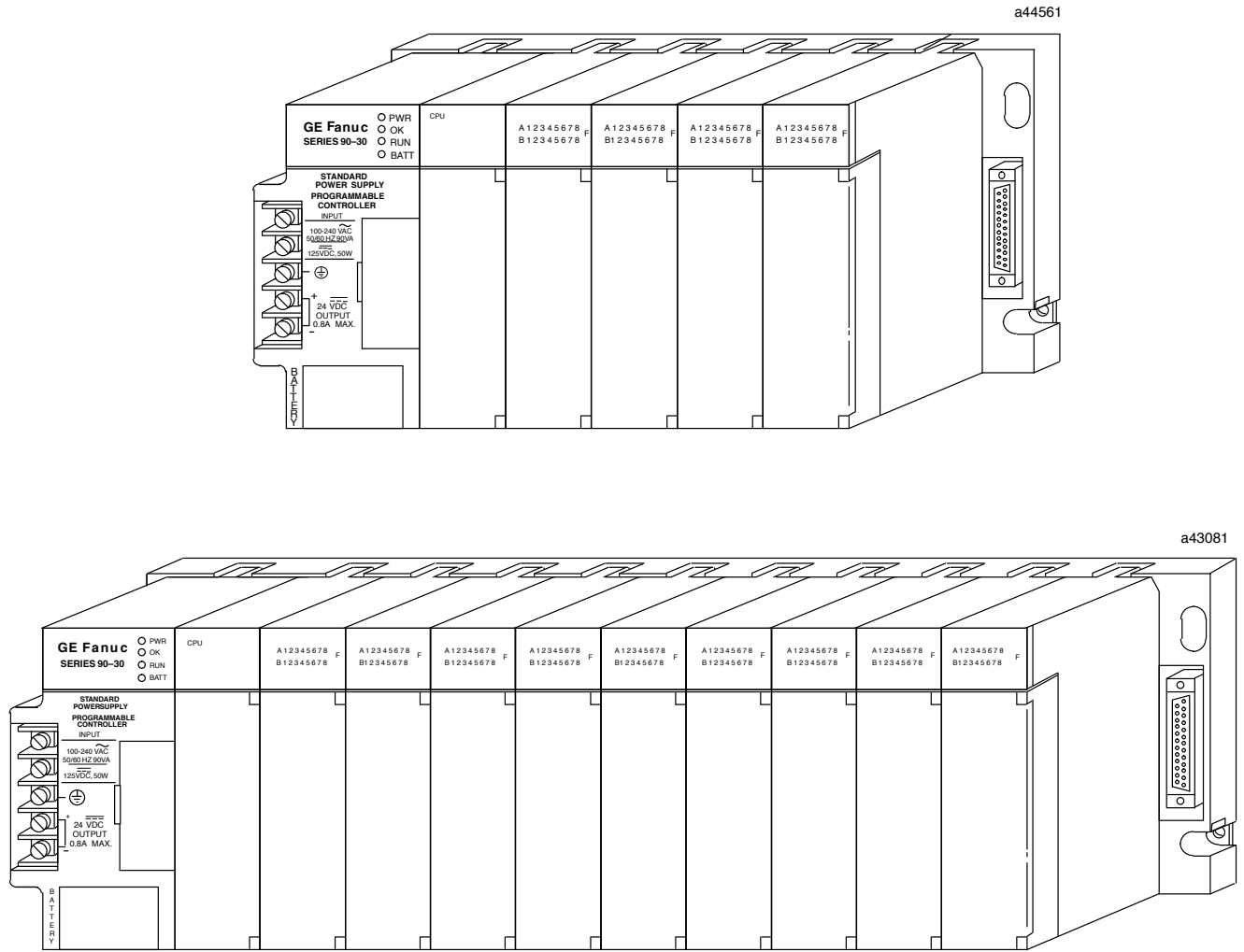

Figure 5-1. Series 90-30, Model 311 or Model 313 Programmable Logic Controller

An example of a 5-slot and a 10-slot Series 90-30 PLC Model 331, 340, 341, or 351 PLC is shown in the following figure (Models 331, 340, 341, and 351 look physically the same).



* The Model 351 CPU faceplate is different than the CPU faceplates shown in the above illustrations. See GFK-0356, the Series 90-30 Programmable Controller Installation Manual for more information.

Figure 5-2. Series 90-30, Model 331, Model 340, Model 341, or Model 351 Programmable Logic Controller

The Series 90-20 PLC hardware configuration consists of an I/O and Power Supply Base Module (baseplate) and a plug-on CPU module. The baseplate contains the discrete input and output circuits, the power supply, and terminal strips for user field wiring. I/O consists of a fixed configuration of 16 inputs and 12 outputs. The following figure is an example of a Series 90-20 PLC.

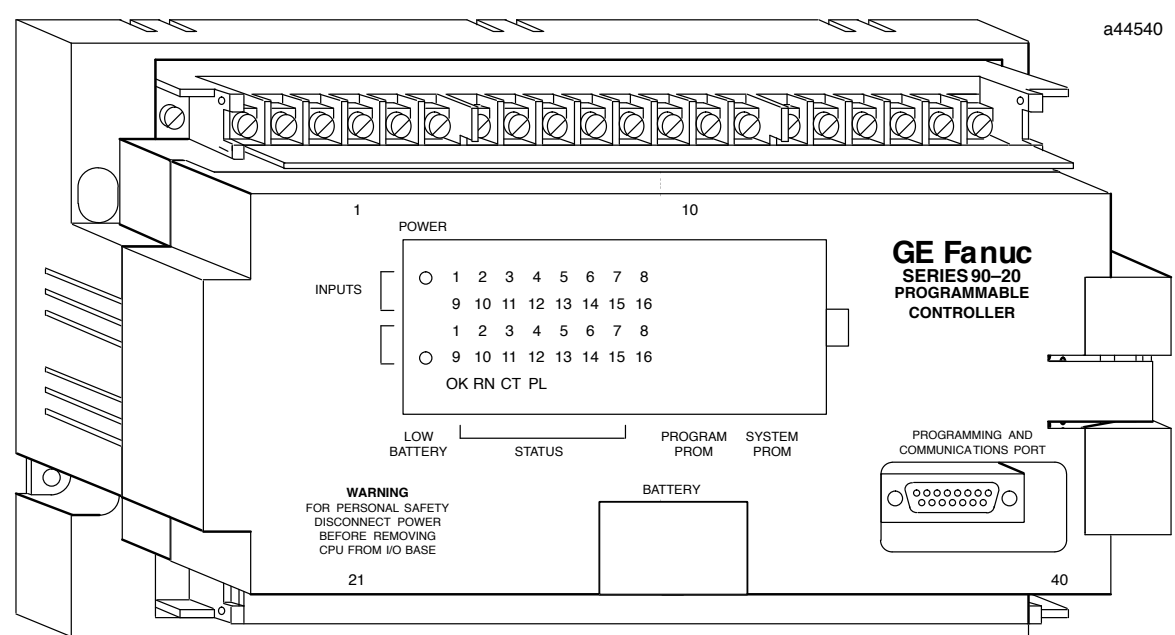

Figure 5-3. Series 90-20 Programmable Logic Controller

I/O configuration for each slot for the Series 90-20 PLC is:



Rack	Slot	Configuration
Rack0	Slot 0	PowerSupply
Rack0	Slot 1	CPU
Rack0	Slot 2	Inputs (%I)
Rack0	Slot 3	Outputs (%Q)
Rack0	Slot 4	High Speed Counter

Selecting Rack Size

The size of each rack can be edited with the HHP by selecting slot 0 for that rack. To select slot 0, first select the CPU slot then press the cursor up key to view the rack size. For example, assume that a 10-slot rack has been powered up by pressing the CLR and M keys which forces the PLC to automatically generate the default configuration. The rack size is displayed and edited as described below.

The initial mode screen is displayed first.





Press the   sequence to go to the config mode.

```
RO:01 PLC    <S  
KEY CLK: OFF
```

Press the  key to view the rack size

```
RO:00 PWR SUP <S  
RK SIZE: 10-SLOT
```

Press   to select the other (5-slot) rack size.

If there are no modules configured in slots 6 through 10, then the new rack size will be selected.

```
RO:00 PWR SUP <S  
RK SIZE: 5-SLOT
```

If there are any modules configured in slots 6 through 10, the following error message is displayed.

```
RO:00 CFG ERR <S  
RK SIZE: 5-SLOT
```

Note

Configuring a rack size different from the actual rack size will produce a *Non-fatal hardware failure* fault in the PLC Fault Table. This is only a diagnostic fault and will not inhibit the PLC from going to RUN mode. Although RUN mode is allowed, problems may occur during RUN mode due to the rack size mismatch.

Selecting Slots in a Rack

Slots in 5-slot racks are selected for display and editing in the same manner as selecting slots in a 10-slot rack.

First, go to the initial config mode screen.

```
RO:01 PLC    <S  
KEY CLK: OFF
```

Then press the  key four times to view the contents of slot 5.



R0:05 EMPTY <S

If the current rack is configured to be a 5-slot rack, the next down arrow key press will display the first slot in rack 1. If the current rack is configured to be a 10-slot rack, then additional presses of the down arrow key will display the contents of slots 6 through 10.

When the PLC automatically generates the default configuration for the system, it will determine the rack size which is present and contains configurable modules. This information will be used to configure the rack size. The reference address mapping for slots in rack 0 is the same when rack 0 is a 5-slot rack as it is when rack 0 is a 10-slot rack.

I/O Slots

Each I/O slot may contain either a discrete, analog, or intelligent module. Intelligent modules include Genius or Enhanced Genius Communications, High Speed Counter, I/O Link Interface, Axis Positioning Modules, I/O Processor Module, and (in the Models 331/340/341/351 only) Programmable Coprocessor, Alphanumeric Display Coprocessor, Communications Control and State Logic Processor modules. A slot may be configured whether or not the module is physically present; if present, the module's characteristics may be *read in* as the default configurations.

Two types of I/O modules may be configured; *non-intelligent and intelligent*. Each of these types is discussed in this chapter.

Remote I/O Rack Configuration

Configuration of remote I/O racks is similar to the configuration of the rack size described previously. A second parameter in the power supply slot - RACK TYPE - must also be configured.

Manual Rack Configuration

If no modules have been configured in a rack, the power supply slot will show EMPTY. If not already configured, the power supply can be added to the configuration in one of two ways. First, any module can be added into an I/O slot of the rack. In this case, the PLC will automatically configure the power supply into slot 0 of the rack. Alternately, the power supply can be configured manually as shown in the following steps:

Initial display:



R1:00 EMPTY <S

To add the power supply to the configuration:

Press the key sequence   :

R1:00 PWR SUP <S
RK SIZE:10-SLOT

Racks can be configured in this manner even if they are not physically present. The default rack type is an expansion rack. If no modules are configured in a rack, then the rack type can be deleted from the configuration by pressing the DEL and ENT keys while viewing the power supply slot for that rack. This can be used to prevent display of power supplies in unused racks when the configuration is to be LOADED to Logicmaster 90-30/20/Micro software.

To view the configured rack, press: 

R:00 PWR SUP <S
RACK TYPE: EXPAN

The configured rack type can be changed if desired. If the actual rack type does not match the configured rack type, then a mismatch alarm will be generated for the power supply slot of that rack and none of the I/O modules in that rack will be scanned. *Note that the rack type of the main rack (rack 0) cannot be changed.*

If you want to select another rack type (for example, a remote rack) use the following procedure.

To select another rack type press: 

R1:00 PWR SUP <S
RACK TYPE: REMOT

The REMOT field will be blinking when this screen is displayed indicating a new type of rack which can be, but has not yet been configured.

To configure the rack as this type, press: 

R1:00 PWR SUP <S
RACK TYPE: REMOT

Notice that the REMOT field is no longer blinking, indicating that the rack is now configured to be a remote rack. If for some reason, you want to abort the operation, you can do so by pressing CLR instead of ENT.

Note

Configuring a rack type different from the actual rack type will produce a *System configuration mismatch* fault in the PLC Fault Table. This fault is a fatal fault and will inhibit the PLC from going to the RUN mode.

Automatic Rack Configuration

When the DEFAULT I/O CPU parameter is enabled, the PLC will automatically configure the modules that are physically present in the system (with some restrictions - refer to *Reconfiguration* later in this chapter for details). When this procedure is selected, the type of the main rack is automatically configured. For other racks, if there are modules in the rack which will be configured, then the rack type for that rack will also be automatically configured. If there are no modules in that rack which are automatically configured, then the power supply slot (also - rack type) will remain EMPTY.

Reading a Saved Configuration

When a saved configuration is read from a user memory device (EEPROM, UVEPROM, MEM card, or flash memory), the type of each rack that was configured when the data was saved is restored. Each rack is compared to the restored configuration and, if the rack types are different a mismatch alarm is generated for slot 0 of that rack. Modules in that rack will not be scanned until the mismatch is corrected.

If the DEFAULT I/O CPU parameter is enabled in the configuration being read, the configured type for each rack in which a module will be configured is set to the type of rack actually present.

None of the modules in a rack that is configured to be a type different than the rack actually present will be scanned. In addition, COMM_REQ function blocks whose target module is in such a rack will have their fault output set if the COMM_REQ is executed. The parameters of intelligent I/O modules in such a rack cannot be edited with the HHP. Loss, mismatch, or addition of module alarms will be generated for modules in the rack as if the rack were not mismatched. For example, if the module in slot 4 matches the module configured for slot 4, then no alarm will be generated for that slot).

Keypad Functionality

The following table is an overview of how the keypad on the Hand-Held Programmer is used in I/O Configuration mode.

Table 5-1. Keypad Functionality in I/O Configuration Mode

Key Group	Description
I/ AI Q/AQ G/S	Specify a module type (I, AI, Q, AQ, QI, AQI,). Used to configure a GCM.
0 - 9 I/ AI (A) Q/AQ (B) M/T (C) AND(D) OR (E) NOT (F)	Specify a slot number, reference address, point count or parameter value; value format may be either binary, signed decimal, or hexadecimal. (A)...(F)- these keys are used to enter hexadecimal digits A...F
HEX/DEC	Change display format between decimal, hexadecimal, and 8-bit binary.
CLR	Abort or cancel the current operation or user input.
Up and Down cursor keys	Select a different slot for viewing.
Left and Right cursor keys	Display a different module parameter or field.
#	Indicate a new rack / slot number (<i>GOTO</i>).
DEL	Delete configuration of currently displayed slot.
READ/VERIFY	Read configuration of module currently installed in slot.
ENT	Complete an operation or user input.
RUN	Start or stop the PLC.
MODE	Select a Hand-Held Programmer operating mode.

Section 1: Non-Intelligent I/O Modules

The following screen format is used to configure non-intelligent I/O modules:

Table 5-2. Configuration of a Non-Intelligent I/O Module

R	Rack #	:	Slot #	unused	Module Type or Message	unused	PLC State
Reference Type	# Points	:	Reference Range (Low Bound)	-	Reference Range (High Bound)		

Rack #, Slot #: The rack # and slot # fields indicate the currently displayed rack and slot. The range of these fields depends on the CPU model (311 or 331) and the backplane (5 or 10 slot) or rack (main or expansion) type.

Module Type or Message: The module type or message field normally displays the currently configured module type. If no module is configured, the module type will be displayed as *EMPTY*. The possible non-intelligent module types are:

I	Discrete Input
Q	Discrete Output
AI	Analog Input
AQ	Analog Output
QI	DiscreteInput/Output

This field also functions as an error message window.

PLC State: The PLC state field indicates whether the PLC is currently stopped or is running (executing a program). A leading < character, followed by *S* if the PLC is stopped or *R* if it is running, indicates the state of the PLC.

Reference Type: The reference type field indicates a memory reference type. Its possible values include *I*, *Q*, *AI*, *AQ*, or *QI*.

Points: The # points field indicates the number of points (discrete modules) or channels (analog modules) supported by the configured module.

Reference Range (Low Bound and High Bound): The low and high bound reference range fields indicate the logical reference address range assigned to the slot. The range is based on the number of points/channels on the module to be installed.

When configuring a slot for a non-intelligent I/O module, both the module type and point/channel count must be provided. If either is invalid (that is, a module type of *R*), the configuration request will be refused and an *EMPTY* message will be displayed. *IOM ERR* is displayed when a wrong point module type is entered. All discrete I/O modules require a point count that is a multiple of 8.

Assigning Reference Addresses to I/O Modules

You can specify where the I/O module should map into the reference tables, or you can allow the module to default to a PLC-assigned range.

When the CPU chooses a default reference, it will always choose an address higher than the highest reference address of this type that has ever been used, regardless of which addresses are currently being used. If such a selection is not possible (because the highest possible address has previously been used), then **REF ERR** will be displayed and you must specify an address.

You must specify a starting reference address whereby the entire module can be mapped into the available reference address space. If the module will not completely *fit* into the reference address space, the configuration request will be refused and a **DAT ERR** message will be displayed.

The starting reference must be on a byte (multiple of 8) boundary in the reference space. If you enter a starting reference not on a byte boundary, it will be automatically adjusted to the next lowest byte boundary and a **REF ADJ** warning will be issued. You can accept the adjusted starting reference by pressing the ENT key a second time, and the configuration of this slot will be complete. Or, you can abort the configuration attempt by pressing the CLR key.

Input addresses (I and AI) may not be overlapped as part of a slot configuration. If you attempt such an overlap, the configuration request will be refused and an **I/OERR** message will be displayed. You must either map this module into a different reference range, or abort the configuration of the module.

For discrete and analog outputs (Q and AQ), the reference range default will be overlaid in the highest range of the map if there is no room left in the address map.

Module configuration changes, whether additions or modifications, can be performed *only* when the PLC is stopped. You must first place the PLC in stop mode before attempting to configure a module. If you attempt to make a change with the PLC running, the configuration request will be refused and a **RUNNING** message will be displayed.

Locating a Slot or Rack

For information on the procedure for locating a slot or rack, refer to Chapter 3, page 3-4 *Locating a Slot or Rack and Parameters*.

Configuring a Discrete Module

Follow this procedure to configure a discrete module:

1. Use the Up and Down cursor keys, or the # key, to display the correct slot in the rack. For example, to configure a 16-point input module in slot 5 of the main rack, the initial display would appear as:



R0:05 EMPTY <S

- Specify the module type (I, AI, Q, AQ, or GCM) by using the I/ AI, Q/ AQ, or G/S key and the ENT key. For this example, press the I/ AI key and then the ENT key to specify an input module in slot 5 of the main rack:

```

R0:05 I      <S
I_

```

- Use the numeral keys and the ENT key on the Hand-Held Programmer to specify the point size. For example, press the 1, 6, and ENT key to identify the input module as a 16-point input module:

```

R0:05 I      <S
I16:I_

```

- Next, enter the reference range. For example, to enter the reference range %I0065 - %I0080, press the key sequence 6, 5; then, press the ENT key:

```

R05:05 I      <S
I16:I0065-I0080

```

The second line of this final display screen shows that a 16-point input module in slot 5 of the main rack is mapped into the reference range %I0065 - %I0080.

If an error is made before the complete data is entered press the CLR key until the data entered is deleted or empty (initial state) is reached.

Reading a Configuration

If a non-intelligent module is already installed in a backplane slot, you may indicate that the actual installed hardware be used as the basis for the configuration. Once this is done, the only additional input needed is to map the module into the reference address space.

In the following example, an 8-point discrete output module is already installed in slot 4 of the main rack. To map this module into the reference range %Q0025 - %Q0032, follow this procedure:

- The initial display appears as:

```

R0:04 EMPTY  <S

```

- Press the READ/VERIFY key:

```

R0:04 READ   <S

```

- Next, press the ENT key:

```

R0:04 Q      <S
Q08:Q_

```

- Press the key sequence 2, 5.

```

R0:04 Q      <S
Q08:Q 25_

```

- Press the ENT key to complete this operation:

```

R0:04 Q      <S
Q08:Q0025-Q0032

```

Deleting an Existing Configuration

The DEL key may be used to delete a non-intelligent module from a particular backplane slot. Use the Up and Down cursor keys, or the # key, to display the configuration of the slot to be deleted. Press the DEL key and then the ENT key to delete the reference type and address from the slot and return it to its initial state (empty).

Replacing a Configuration

To change the current configuration by replacing the reference type, you must first delete the existing slot configuration and then enter the new configuration, as previously described. If the module type remains the same and only the reference address changes, you can simply enter the new data *over top* of the old data.

The following example shows how to remap the currently configured 8-point discrete output module from the reference range %Q0025 - %Q0032 to the reference range %Q0033 - %Q0040.

- The initial display appears as:

```

R0:04 Q      <S
Q08:Q0025-Q0032

```

- Press the key sequence 3, 3 for the new reference range:

```

R0:04 Q      <S
Q08:Q 33_

```

- Then, press the ENT key to complete this replacement operation:

```

R0:04 Q      <S
Q08:Q0033-Q0040

```

Canceling a Configuration Operation

The CLR key may be used to cancel the current configuration operation and leave the slot in its initial state. With the current configuration displayed on the screen, press the CLR key once to cancel the reference address.

Press the CLR key a second time to delete the reference type and return the slot to its initial state.

This must be done before the configuration is complete, that is, the high reference has been entered. If configuration is complete, it must be deleted and data entered from the beginning.

Reconfiguration

You can request that the PLC reconfigure the I/O based on the default configuration algorithm. To do this, type a special key sequence (shown below) on the Hand-Held Programmer when the Hand-Held Programmer is in the Configuration Mode. The Hand-Held Programmer does not have to be on any particular screen, but the PLC must be in the STOP mode and not scanning I/O. The following example shows how to request a new configuration.

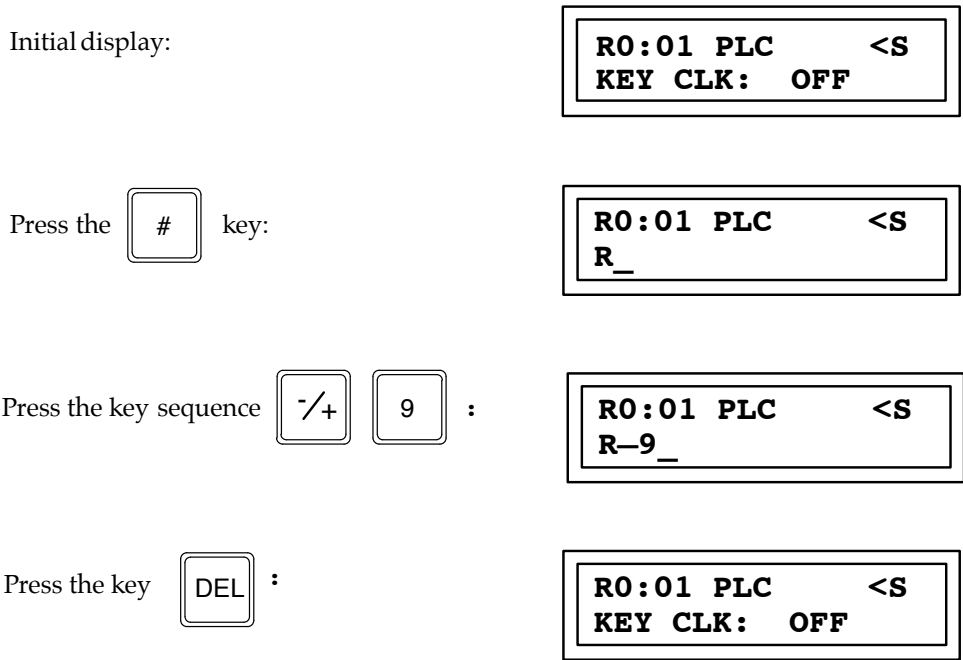

System Configuration - Default

When a Series 90-30 PLC is powered-up, a default I/O configuration is available with no intervention by the user - it happens automatically. The following table shows how I/O references are assigned to each slot in the PLC. The 5-slot Models 311 and 313 PLC will have I/O addresses assigned to every slot. The 10-slot Model 313 PLC will have discrete I/O addresses assigned to each slot, but slots 9 and 10 will not be assigned analog I/O addresses. The Model 331 / 340 / 341 / 351 PLCs will have analog and discrete addresses assigned to 15 of its slots (Rack 0, Slot 2 to Rack 1, Slot 6).

Table 5-3. Default I/O Configuration

Rack	Slot	Discrete Input	Discrete Output	Analog Input	Analog Output	Notes
0	1	%I001-032	%Q001-032	%AI001-008	%AQ001-004	This slot not configured in Models 331, 340, 341, or 351
0	2	%I033-064	%Q033-064	%AI009-016	%AQ005-008	
0	3	%I065-096	%Q065-096	%AI017-024	%AQ009-012	
0	4	%I097-128	%Q097-128	%AI025-032	%AQ013-016	
0	5	%I129-160	%Q129-160	%AI033-040	%AQ017-020	
0	6	%I161-192	%Q161-192	%AI041-048	%AQ021-024	This is the last slot in a 10-slot Model 313 to receive analog configuration
0	7	%I193-224	%Q193-224	%AI049-056	%AQ025-028	
0	8	%I225-256	%Q225-256	%AI057-064	%AQ029-032	
0	9	%I257-288	%Q257-288	%AI065-072	%AQ033-036	
0	10	%I289-320	%Q289-320	%AI073-0080	%AQ037-040	
1	1	%I321-352	%Q321-352	%AI081-088	%AQ041-044	
1	2	%I353-384	%Q353-384	%AI089-096	%AQ045-048	
1	3	%I385-416	%Q385-416	%AI097-104	%AQ049-052	
1	4	%I417-448	%Q417-448	%AI105-112	%AQ053-056	
1	5	%I449-480	%Q449-480	%AI113-120	%AQ057-060	
1	6	%I481-512	%Q481-512	%AI121-128	%AQ061-064	This is last slot to receive configuration in Models 331 / 340 / 341 / 351
1	7	-	-	-	-	
1	8	-	-	-	-	
1	9	-	-	-	-	
1	10	-	-	-	-	

For those users who want to configure a system different than the default (additional I/O modules, different I/O references, etc.) - system configuration can be done by the user with either the Hand-Held Programmer or with the Configuration Software available with the Logicmaster 90-30 / 20 / Micro Programming Software.

I/O Link Interface Module Configuration

The I/O Link Interface module provides an interface between the Series 9 0-30 PLC and the Fanuc I/O Link. This module operates as a slave device. The module can be configured as a 32 point or 64 point Input and Output (combination) module by positioning a jumper on the board. When set for 64 I/O points, the module will be configured with the HHP using the same key sequences and displays that are used to configure the 64-point generic I/O module.

For more information on assigning I/O references, see page 5-10, *Assigning Reference Addresses to I/O Modules*.

Configuration Sequence

The following examples show the key sequences and resulting displays with which to configure the I/O Link Interface module when it is set for 32 I/O points.

Initial display:

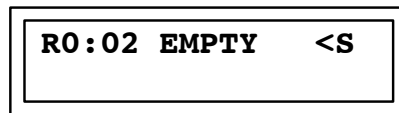

Press the  key:

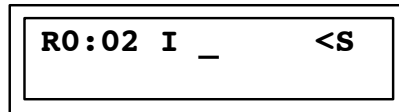

Press the  key:

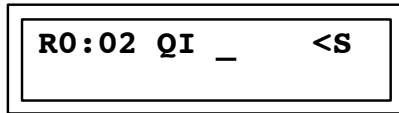

Press the  key:

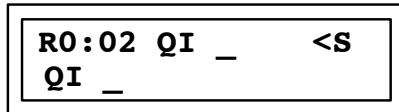

Note that the I/AI and Q/AQ keys could have been pressed in the reverse order with the same result; a module type of QI.

Press the key sequence:

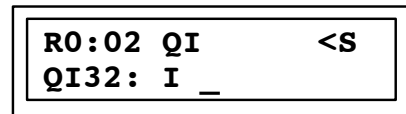

At this point the desired reference address can be entered. The same restrictions apply to the I/O Link Interface modules as to any other I/O Modules. In addition, since the %I

references and %Q references must be the same the HHP will automatically program the %Q reference when you program the %I reference. This restriction also currently exists for the Series 90-30 High Speed Counter (HSC).

If you change either the %I or %Q reference, the HHP will again automatically program both references to the new value and a *REFADJ* message will appear on the HHP screen. In the following example, an I/O Link Interface module is assigned the references %I0001-%I0032 and %Q001-%Q0032.

Initial display:

```
R0:02 QI <S
Q132: I _
```

Press the key sequence



```
R0:02 QI <S
QI32:I0001-I0032
```

Press the



key:

```
R0:02 QI <S
Q132:Q0001-Q0032
```

The following method for configuring the I/O Link Interface module can only be used when the module is physically present in the slot.

Initial display:

```
R0:02 EMPTY <S
Q132: I _
```

Press the key sequence



```
R0:02 QI <S
Q132:I _
```

You can now enter the desired reference address.

Section 2: Intelligent I/O Modules

Two additional screen formats may be encountered when attempting to configure an intelligent I/O module.

Table 5-4. Configuration of an Intelligent I/O Module (Installed)

R	Rack #	:	Slot #	unused	Module Type or Message	unused	PLC State
Parameter Label & Parameter Value							

Table 5-5. Configuration of an Intelligent I/O Module (Not Installed)

R	Rack #	:	Slot #	unused	B	Boardid	M	Moduleid	unused	PLC State
Parameter Label & Parameter Value										

Parameter Label: The parameter label field contains a module-supplied text string used as a prompt to the user for a particular parameter.

Parameter Value: The parameter value field contains a value input by the user. The display format may be binary, signed decimal, or hexadecimal. Each parameter value has an acceptable range. If an illegal value is entered which does not fit in this range, the configuration request will be refused and a *DATERR* message will be displayed.

The configuration of an intelligent I/O module requires that the module be currently plugged into the backplane of the PLC.

Reading a Configuration

Intelligent I/O modules are capable of providing the PLC with a configuration file which describes the parameters it requires. This description includes any associated I/O reference range mapping, the number of parameters, a text string for each parameter to be used as a prompt, the valid data value range for each parameter, and the default data display format (binary, signed decimal, or hexadecimal) which the data should be displayed/input in. In order for this information to be used, you must indicate to the PLC that it should *read* the indicated slot in which the intelligent module resides. If the indicated slot does not contain a module, the configuration request will be refused and an *EMPTY* message will be displayed. You must then install the desired module in the slot and attempt the operation again.

Section 3: Genius Communications Module

The Series 90-30 Genius Communications module is an intelligent module that provides automatic, global data communications between a Series 90-30 PLC and other PLCs. Refer to GFK-0412, Series 90-30 Genius Communications Module User's Manual for more information on this module. Refer to the Series 90-30 Enhanced Genius Communications Module User's Manual (GFK-0695) for information on configuration of that module with the Hand-Held Programmer.

Reading a Configuration

The Genius Communications module cannot actually be *read* to determine its current configuration. When a command is initiated to read the slot containing a Genius communications module, the PLC will respond with the default set of parameters for the module. These defaults may be edited and then stored to the module the same as for any other module.

In the following example, a Genius Communications module has been installed in slot 6 of the main rack (0), but the slot has not been configured.

1. The initial display screen shows that slot 6 in the main rack has not yet been configured:

```

R0:06 EMPTY <S

```

2. Press the READ/VERIFY key and then the ENT key to *read* the configuration from the Genius Communications module residing in this slot:

```

R0:06 GCM <S
BUS ADR: 16

```

The first parameter, the BUS ADR parameter, assigns a node address in the range 16 to 23, inclusive, to the module. Any data the module broadcasts will be identified by its bus address.

3. For example, to assign a bus address of 17 to the module, press the key sequence 1, 7, ENT.

```

R0:06 GCM <S
BUS ADR: 17

```

4. Press the Right cursor key to select the next parameter, which is baud rate. This parameter indicates the baud rate of the Genius bus. Four baud rates are supported, 153.6K standard, 76.8K, 38.4K, and 153.6K extended, where 153.6K standard is the default. You may use the -/+ key to scroll through these selections. When the correct baud rate is displayed, press the ENT key to accept it, then press the \rightarrow (right cursor) key to select the next parameter.

5. The next parameter is the first of eight which defines the relative mapping of each node (16 through 23, inclusive) on the Genius bus into the global (G) memory space. By default, 32 bits are assigned to each node, accounting for the full 256 bits supported by the module. The following table shows the starting address and data size for each bus address:

Bus Address	Starting G Reference Address	Valid Data Size (Bits)
16	G0001	0 ... 256
17	G0033	0 ... 224
18	G0065	0 ... 192
19	G0097	0 ... 160
20	G0129	0 ... 128
21	G0161	0 ... 96
22	G0193	0 ... 64
23	G0225	0 ... 32

Press the Right cursor key to view each of the default node bus address assignments. In this example, the Genius Communications module will occupy bus address 17.

6. Press the Right cursor key to display the screen showing 17 as the bus address.

```
R0:06 GCM*BA17<S
G032:G0033-G0064
```

The asterisk (*) character preceding the bus address indicator (BA17) denotes that address as being assigned to the Genius Communications module for data transmission. All other nodes are for data reception from other devices.

7. For this example, the Genius Communications module will be configured to support 32 bits on node 16, 64 bits on node 17, and 128 bits on node 20. Nodes 18, 21, 22, and 23 will not support any data as they are *covered* by the requirements of nodes 17 and 20. No device is installed on node 19, so it will not be used.
8. Node 16 is already configured for 32 bits by default, so no change is required.
9. Press the Right cursor key to display node 17. Node 17 needs to support 64 bits, so this setting must be modified by pressing the key sequence 6, 4, ENT.

```
R0:06 GCM BA17<S
G064:G0033-G0096
```

10. Node 18 is skipped because its 32 bits are used as part of node 17's configuration. No device is installed as node 19, so no data is expected from it. Press the Right cursor key to display node 19, then press 0, ENT.

```
R0:06 GCM BA19<S
G000:
```

Note that the 32 references associated with node 19, G0097 - G0128, are now lost to the user.

11. Press the Right cursor key to display node 20. Then, press the key sequence 1 2 8 .

```

RO:06 GCM BA20<S
G 128_

```

12. Press the ENT key:

```

RO:06 GCM BA20<S
G128:G0129-G0256

```

Since all 256 bits are now accounted for, you will not be allowed to view the settings for nodes 21, 22, or 23, or make assignments to them.

Creating a Generic Module Configuration

The G/Skey may be used to configure a slot for a Genius Communications module not currently installed in the slot.

1. With slot 6 displayed in its initial state as empty, press the G/S key:

```

RO:06 GCM_ <S

```

2. Then, press the ENT key. The same default configuration is established, as previously described.

```

RO:06 GCM <S
BUS ADR: 16

```

Section 4: High Speed Counter

The Series 90-30 High Speed Counter (HSC), catalog number IC693APU300, module provides direct processing of rapid pulse signals up to 80 kHz for industrial control applications. This module is able to sense inputs, process the input count information, and control the outputs without needing to communicate with a CPU.

The High Speed Counter parameters can be configured using the HHP as described in the Series 90-30 High Speed Counter User's Manual, GFK-0293.

Note that with an earlier version (release 1) of the Series 90-30 PLC, only the first 15 configuration parameters for the HSC were saved in volatile RAM memory. This version of the PLC (release 2) allows all 78 bytes to be saved. To save ALL of the High Speed Counter parameters in the non-volatile RAM of a PLC (release 2 or later) simply edit the parameters as described in the HSC manual. When power is cycled, ALL of the edited parameters will be sent to the HSC by the CPU.

For details of using the Hand-Held Programmer to configure the High Speed Counter, refer to Chapter 6, *Configuration Programming* in the Series 90-30 High Speed Counter User's Manual (GFK-0293).

Section 5: Programmable Coprocessor Module

Editing PCM Parameters

Programmable Coprocessor Module parameters can be edited with the Hand-Held Programmer if you have a Release 3 or later CPU and a Release 2.51 or later PCM. The parameters are edited in exactly the same manner as for Intelligent I/O Modules described previously in this chapter.

Freezing configuration

Processing a change to the PCM's configuration takes 15 seconds or more. Processing multiple parameter changes simultaneously takes the same time as processing a change to a single parameter. Since changing several parameters at once is a common occurrence, changes to individual parameters are remembered by the module but are not processed and do not take effect until specifically commanded to do so.

When a PCM parameter is changed, an asterisk (*) will appear before the module name on the top line of the HHP screen. This indicates that the module's previous configuration has been *frozen*, and that the module is not yet using the change(s) you have just made. You can continue editing, and this and all subsequent changes will be remembered by the module. However, if power is lost while a module's configuration is frozen, the changes (edits) you have made will be lost.

When the configuration for a module is frozen in this manner, you can tell the system that editing of all of the parameters is complete by pressing the WRITE and ENT keys. The edited changes are then processed all at once by the PCM and the asterisk will disappear from the display, indicating that the new values are being used by the PCM and have been saved in the PLC's non-volatile memory.

If you decide to abandon the changes that you have made so far, they can be discarded by pressing the CLR and ENT keys. If you do this, the configuration parameters will revert to the values they had before the configuration was frozen.

If you attempt to leave the current slot (either by pressing the *, -*, or # key) while the module's configuration is frozen, you will be prompted to indicate whether to use the new combination of values, discard the new values and return to the old configuration, or to continue editing the changes. If you attempt to change the HHP mode or go to RUN mode, the **FROZEN** error message will be displayed. *Once changes have been made which are not being used by the module, you cannot leave the slot until the changes are saved or discarded.*

Example of Editing a PCM

For this example, assume that a 192K PCM (IC693PCM301) module resides in slot 2 of the CPU rack and that the PLC was powered up with the CLR and M/T keys depressed (that is, the PLC was cleared). In this example, we want to change the mode from CCM only (the default) to PROGRAMMER PORT and to change the data rate for both ports to 9600 baud.

Initial display:

```
RO:02 PCM301 <S  
VERSION:3.01
```

To view the mode parameter:

Press the  key:

```
RO:02 PCM301 <S  
MODE:CCM ONLY
```

To view other possible modes,

Press the  key:

```
RO:02 PCM301 <S  
MODE:PROGRAM PRT
```

Each time that you press the -/+ key, other modes will be displayed. When the desired mode is displayed (it will be blinking),

Press the  key:

```
RO:02*PCM301 <S  
MODE:PROGRAM PRT
```

The asterisk to the left of PCM indicates that the module's configuration is now frozen. That is, the new mode value of PROGRAMMER PORT is remembered and displayed, but the module is still using the old value of CCM ONLY. If power were cycled at this time, the mode parameter would have the old value of CCM ONLY.

If you should attempt to change HHP modes or go to RUN mode when the module's configuration is frozen, the *FROZEN* error message will be displayed. For example:

Press the  key:

```
RO:08 FROZEN <S  
MODE:PROGRAM PRT
```

To refresh the display of the module name, press any key, for example:

Press the  key :

```
RO:02*PCM301 <S  
MODE:PROGRAM PRT
```

If an attempt is made to view the configuration of a module in another slot at this time, the HHP will prompt you for the changes. For example:

Press the  key:

```
SAVE CHANGES? <S  
<ENT>=Y <CLR>=N
```

Since the port baud rate parameters have not yet been edited at this point in our example, we do not want to save the changes yet.

Press the  key:

```
DISCARD CHGS? <S  
<ENT>=Y <CLR>=N
```

If the changes are discarded at this time, we will lose the change we made to the mode parameter. That is, the configuration would revert to CCM ONLY, which is what it was before the configuration was frozen. Since we have more parameters to edit:

Press the  key:

```
RO:02*PCM301 <S  
MODE:PROGRAM PRT
```

Again, the asterisk indicates that the module's configuration is still frozen and the edited changes are not yet being used by the module. To display the baud rate parameter for port 1,

Press the key sequence   :

```
RO:02*PCM301 <S  
DATA RT 1:19200
```

Notice that the asterisk remains to the left of the module's name. This indicates that the module's configuration is still frozen. It is possible to edit this and other parameters at this time, however none of the changes will be used by the module until they are saved as indicated below.

To change the port 1 baud rate to 9600:

Press the  key:

```
RO:02*PCM301 <S
DATA RT 1:9600
```

To display the baud rate parameter for port 2:

Press the  key six times:

```
RO:02*PCM301 <S
DATA RT 2:19200
```

To change the port 2 baud rate to 9600:

Press the  key:

```
RO:02*PCM301 <S
DATA RT 2:9600
```

To save the edited changes that we have made:

Press the  key:

```
SAVE CHANGES? <S
<ENT>=Y <CLR>=N
```

If the CLR key is pressed at this time, the SAVE operation will be aborted. Since we do want to save the changes,

Press the  key:

```
PROCESSING <S
CHANGES
```

The word PROCESSING will continue to blink until the module has completed processing of the new values. The HHP will then redisplay the last parameter that had been displayed:

```
RO:02 PCM301 <S
DATA RT 2:9600
```

Notice that the asterisk to the left of PCM301 is gone, indicating that the configuration is no longer frozen and that the module is using the new values.

To continue the example, suppose that you start changing parameters, then realize that you have made a mistake. The changes made so far (that is, since the configuration was frozen) can be discarded, reverting to the previous configuration.

Change the baud rate parameter for port 2 to 4800:

Press the   key sequence:

```
RO:02*PCM301 <S  
DATA RT 2:4800
```

Notice that the configuration is frozen and that the actual baud rate being used by the PCM is 9600 (the previously configured baud rate).

To discard the changes,

Press the  key:

```
DISCARD CHGS? <S  
<ENT>=Y <CLR>=N
```

If you press CLR again at this time, the discard operation would be aborted.

Press the  key:

```
RO:02 PCM301 <S  
DATA RT 2:9600
```

The module's configuration is no longer frozen. The parameters have the same value they had before we changed the baud rate to 4800. Since the specific application will vary from module to module, the PCM User's Manual (GFK-0255) should be consulted for information on editing specific parameters.

Section 6: Analog I/O Modules

This section describes configuration of Series 90-30 Analog I/O modules with the Hand-Held Programmer. The analog I/O modules included in this section are:

- IC693ALG222 - Voltage Input (16 Channels)
- IC693ALG223 - Current Input (16 Channels)
- IC693ALG392 - Current/Voltage Output (8 Channels)
- IC693ALG442 - Current/Voltage Combination Module (4 Input/2 Output Channels)

For detailed information on Series 90-30 Analog I/O modules, refer to GFK-0898, the *Series 90-30 Programmable Controller I/O Module Specifications* manual.

Configuring the 16-Channel Voltage Input Module

The *16-Channel Analog Voltage Input* module, catalog number IC693ALG222, provides up to 16 single-ended or eight differential input channels, each capable of converting an analog input signal to a digital value for use as required by your application. This module provides two input ranges:

- 0 to 10 V (unipolar)
- -10 to +10 V (bipolar)

Voltage Ranges and Input Modes

The default input mode and range is single-ended, unipolar, with the user data scaled so that 0 volts corresponds to a count of 0 and 10 volts corresponds to a count of +32000. The other range and mode are selected by changing the configuration parameters using the Logicmaster 90-30 configurator software or the Hand-Held Programmer. The range can be configured for bipolar -10 to +10 V where -10 V corresponds to a count of -32000, 0 V corresponds to a count of 0, and +10 V corresponds to a count of +32000.

High and Low alarm limits are available on all ranges. Ranges can be configured on a per channel basis.

Although you can change the number of actively scanned channels with the Logicmaster 90-30 configurator function, the Hand-Held Programmer does not support editing the number of actively scanned channels. If the 16-Channel Analog Voltage Input module is initialized by a Hand-Held Programmer, the number of actively scanned channels is 16.

If a module had been previously configured with Logicmaster 90-30 software and the number of actively scanned channels has been changed from 16, that number will be displayed on the bottom line of the Hand-Held Programmer display following the *AI*. You can edit data with the Hand-Held Programmer only for the active channels, but can not change the number of actively scanned channels.

Module Present

If a module is physically present in a system, it can be added to the system's configuration by *reading* the module into it. For example, assume that a 16-Channel Analog Voltage Input module is installed in slot 3 of a Model 311 PLC system. It can be added to the configuration with the following sequence. Use the Up and Down cursor keys or the # key to display the selected slot.

Initial Display

```
RO:03 EMPTY >S
```

To add the IC693ALG222 module to the configuration, press the **READ/VERIFY** key. The following screen will be displayed:

```
RO:03 HI-DEN V >S  
I40:I_
```

Note

This field cannot be changed with the Hand-Held programmer. However, it can be changed using the Logicmaster 90-30 software configurator function. The Hand-Held Programmer will always reflect the currently active length of the status field.

For more information on assigning I/O references, see page 5-10, *Assigning Reference Addresses to I/O Modules*.

Pressing the **ENT** key will allow the PLC to select the starting address of the status data. You can select a specific starting address by pressing the key sequence for the desired address and pressing the **ENT** key. For example to specify the starting address as I17, press the key sequence 1, 7, **ENT**. The following screen will be displayed:

```
RO:03 HI-DEN V >S  
I40:I17-I56
```

Selecting %AI Reference

After the starting %I address has been selected, pressing the **ENT** key again will cause the following screen to be displayed:

```

RO:03 HI-DEN V >S
AI16:AI_

```

This screen allows you to select the starting address for the %AI reference. Note that the length of the status field (16) is displayed as the first two digits following the first **AI** on the second line of the display.

Note

This field cannot be changed with the Hand-Held programmer. However, it can be changed using the Logicmaster 90-30 software configurator function. The Hand-Held Programmer will always reflect the currently active length of the status field.

In the AI field you can select the next available address (the default) by pressing the **ENT** key or by entering a specific address. To enter a specific address, press the starting reference number keys and the **ENT** key (for example 3, 5, then **ENT**).

```

RO:03 HI-DEN V >S
AI16:AI035-AI051

```

You can press the **CLR** key at any time to abort the configuration you have just selected and return the slot to *EMPTY*.

Removing Module From Configuration

If required, this module can be removed from the current configuration. Assume that the module is currently configured in rack 0, slot 3. It can be deleted with the following sequence:

Initial Display

```

RO:03 HI-DEN V >S
AI16:AI_

```

To delete the module, press the **DEL**, **ENT** key sequence. The display will then be:

```

RO:03 EMPTY >S

```

Selecting Module Mode

To display the module mode, press the \rightarrow key. The display will show the current mode of the module. The default mode is Single Ended.

```
RO:03 HI-DEN V >S
HI-DEN V:SINGLE
```

You can toggle between the Single Ended and Differential modes by pressing the \pm key. Each mode will be selected as shown. The range selected is the one currently displayed.

```
RO:03 HI-DEN V >S
HI-DEN V:DIFFERE
```

When the desired mode for the module is displayed on the screen you can select it by pressing the ENT key.

Selecting Input Channel Ranges

The range for each of the 16 channels can be displayed and selected or changed as described below. Assume that the %AI address is as previously selected.

```
RO:03 HI-DEN V >S
HI-DEN V:SINGLE
```

To display the channel ranges press the \rightarrow key. The display will show Channel 1 (or the currently selected channel) and the first available range.

```
RO:03 HI-DEN V >S
CHAN 1: 0 - 10
```

You can toggle through the range for each channel by pressing the \pm key. Each range will be displayed as shown. The range selected is the one currently displayed.

```
RO:03 HI-DEN V >S
CHAN 1:-10 - 10
```

Alarm Limits Display

To view the alarm limits for the channel currently displayed, press the → key again (the first time caused the channel ranges to be available for editing). The following screen is displayed:

```

RO:03 HI-DEN V >S
CH 1 LO:      0

```

The display is the entry field for the low alarm limit for the displayed channel (in this case, Channel 1). You can enter the desired low alarm limit value using the numeric keys and the ± key for specifying negative values. Enter the low alarm limit using a value within the valid limits as listed in Table 3-7. After you have entered the low alarm limit value, press the → key again to advance to the high alarm limit display for this channel. The following screen is displayed at this time.

```

RO:03 HI-DEN V >S
CH 1: HI: 32000

```

The display shows the entry field for the high alarm limit for the currently displayed channel. You can enter positive or negative numbers (see table 3-7) using the ± and numeric keys. After selecting the low and high alarm limits for channel 1 (or the currently displayed channel), you can view the next channel by pressing the → key.

```

RO:03 HI-DEN V >S
CHAN 2:0 - 10

```

Edit the range, and low and high alarm limits as described for Channel 1. All active channels can be changed in this manner. Return to the initial display screen by pressing the ENT key or by pressing the ← key until the initial screen is displayed.

Saved Configurations

Configurations that contain a 16-Channel Analog Voltage Input module can be saved to an EEPROM or MEM card and read into the CPU at a later time. MEM cards and EEPROMs containing these configurations can be read into any Release 4 or later CPU. Refer to Chapter 2 of this manual for detailed information on the Save and Restore operations.

Configuring the 16-Channel Current Input Module

The *16-Channel Analog Current Input* module, catalog number IC693ALG223, provides up to 16 single-ended input channels, each capable of converting an analog input signal to a digital value for use as required by your application. This module provides three input ranges:

- 4 to 20 mA
- 0 to 20 mA
- 4 to 20 mA Enhanced

Current Ranges

The default range is 4 to 20 mA with user data scaled so that 4 mA corresponds to a count of 0 and 20 mA corresponds to a count of 32000. The other ranges are selected by changing the configuration parameters using the IC641 configurator software or the Hand-Held Programmer. The range can be configured so that the input range is 0 to 20 mA with user data scaled so that 0 mA corresponds to a count of 0 and 20 mA corresponds to a count of 32000. Full 12-bit resolution is available over the 4 to 20 and 0 to 20 mA ranges.

A 4 to 20 mA Enhanced range can also be selected. When this range is selected, 0 mA corresponds to a count of -8000, 4 mA corresponds to a count of 0 (zero) and 20 mA corresponds to a count of +32000. The Enhanced range uses the same hardware as the 0 to 20 mA range but automatically provides 4 to 20 mA range scaling with the exception that negative digital values are provided to the user for input current levels between 4 mA and 0 mA. This gives you the capability of selecting a low alarm limit that detects when the input current falls from 4 mA to 0 mA, which provides for open-wire fault detection in 4 to 20 mA applications. High and Low alarm limits are available on all ranges. Ranges can be configured on a per channel basis. The module also reports module status and user-side supply status to the CPU.

Although you can change the number of actively scanned channels with the Logicmaster 90-30 configurator function, the Hand-Held Programmer does not support editing the number of actively scanned channels. If the 16-Channel Analog Input module is initialized by a Hand-Held Programmer, the number of actively scanned channels is 16.

If a module had been previously configured with Logicmaster 90-30 software and the number of actively scanned channels has been changed from 16, that number will be displayed on the bottom line of the Hand-Held Programmer display following the *AI*. You can edit data with the Hand-Held Programmer only for the active channels, but can not change the number of actively scanned channels.

Module Present

If a module is physically present in a system, it can be added to the system's configuration by *reading* the module into it. For example, assume that a 16-Channel Analog Current Input module is installed in slot 3 of a Model 311 PLC system. It can be added to the configuration with the following sequence. Use the Up and Down cursor keys or the # key to display the selected slot.

Initial Display

```
RO:03 EMPTY >S
```

To add the IC693ALG223 module to the configuration, press the **READ/VERIFY** key. The following screen will be displayed:

```
RO:03 HI-DEN C >S  
I40:I_
```

For more information on assigning I/O references, see page 5-10, *Assigning Reference Addresses to I/O Modules*.

Selecting %I Reference

At this point the starting %I reference address for the status data returned from the module must be entered. Notice that the length of the status field (**40**) is displayed as the first two digits following the first **I** on the second line of the display.

Note

This field cannot be changed with the Hand-Held programmer. However, it can be changed using the LogiMaster 90-30 software configurator function. The Hand-Held Programmer will always reflect the currently active length of the status field.

Pressing the **ENT** key will allow the PLC to select the starting address of the status data. You can select a specific starting address by pressing the key sequence for the desired address and pressing the **ENT** key. For example to specify the starting address as I17, press the key sequence **1, 7, ENT**. The following screen will be displayed:

```
RO:03 HI-DEN C >S  
I40:I17-I56
```

Selecting %AI Reference

After the starting %I address has been selected, pressing the **ENT** key again will cause the following screen to be displayed:

```

RO:03 HI-DEN C >S
AI16:AI_

```

This screen allows you to select the starting address for the %AI reference. Note that the length of the status field (16) is displayed as the first two digits following the first **AI** on the second line of the display.

Note

This field cannot be changed with the Hand-Held programmer. However, it can be changed using the Logicmaster 90-30 software configurator function. The Hand-Held Programmer will always reflect the currently active length of the status field.

In the AI field you can select the next available address (the default) by pressing the **ENT** key or by entering a specific address. To enter a specific address, press the starting reference number keys and the **ENT** key (for example 3, 5, then **ENT**).

```

RO:03 HI-DEN C >S
AI16:AI035-AI051

```

You can press the **CLR** key at any time to abort the configuration you have just selected and return the slot to *EMPTY*.

Removing Module From Configuration

If required, this module can be removed from the current configuration. Assume that the module is currently configured in rack 0, slot 3. It can be deleted with the following sequence:

```

RO:03 HI-DEN C >S
AI16:AI_

```

To delete the module, press the **DEL**, **ENT** key sequence. The display will then be:

```

RO:03 EMPTY >S

```

Selecting Input Channel Ranges

The range for each of the 16 channels can be displayed and selected or changed as described below. Assume that the %AI address is as previously selected.

initial display

```
RO:03 HI-DEN C >S
AI16:AI035-AI051
```

To display the channel ranges press the → key. The display will show Channel 1 (or the currently selected channel) and the first available range.

```
RO:03 HI-DEN C >S
CHANNEL 1: 4-20
```

You can toggle through the range for each channel by pressing the ± key. Each range will be displayed as shown. The range selected is the one currently displayed.

```
RO:03 HI-DEN C >S
CHANNEL 1: 0-20
```

```
RO:03 HI-DEN C >S
CHANNEL 1: 4-20+
```

Alarm Limits Display

To view the alarm limits for the channel currently displayed, press the → key again (the first time caused the channel ranges to be available for editing). The following screen is displayed:

```
RO:03 HI-DEN C >S
CHAN 1 LO: 00000
```

The display is the entry field for the low alarm limit for the displayed channel (in this case, Channel 1). You can enter the desired low alarm limit value using the numeric keys and the ± key for specifying negative values. Enter the low alarm limit using a value within the valid limits as listed in Table 2. After you have entered the low alarm limit value, press the → key again to advance to the high alarm limit display for this channel. The following screen is displayed at this time.

```
RO:03 HI-DEN C >S  
CHAN 1 HI: 32000
```

The display shows the entry field for the high alarm limit for the currently displayed channel. You can enter positive or negative numbers (see table 2) using the \pm and numeric keys. After selecting the low and high alarm limits for channel 1 (or the currently displayed channel), you can view the next channel by pressing the \rightarrow key.

```
RO:03 HI-DEN C >S  
CHANNEL 2: 4-20
```

Edit the range, and low and high alarm limits as described for Channel 1. All active channels can be changed in this manner. Return to the initial display screen by pressing the ENT key or by pressing the \leftarrow key until the initial screen is displayed.

Saved Configurations

Configurations that contain a 16-Channel Analog Current Input module can be saved to an EEPROM or MEM card and read into the CPU at a later time. MEM cards and EEPROMs containing these configurations can be read into any Release 4 or later CPU. Refer to Chapter 2 of this manual for detailed information on the Save and Restore operations.

Configuring the 8-Channel Current/Voltage Input Module

The *8-Channel Analog Current/Voltage Output* module, catalog number IC693ALG392, provides up to eight single-ended output channels with current loop outputs or voltage outputs. Each analog output channel is capable of providing two current output ranges or two voltage output ranges. Each channel can be individually configured for the output range required for your application. The module has no jumpers or switches for configuration.

All ranges can be configured using either the Logicmaster 90-30 programming software configurator function or the Series 90-30 Hand-Held Programmer. The default range is 0 to +10 volts. Configurable current and voltage output ranges are:

- 0 to +10 volts (unipolar)
- -10 to +10 volts (bipolar)
- 0 to 20 milliamps
- 4 to 20 milliamps

Each channel is capable of converting 15 to 16 bits (depending on the range selected) of binary (digital) data to an analog output for use as required by your application. All eight channels are updated every 12 ms. User data in the %AQ registers is in a 16-bit 2's complement format. In current modes, an *open-wire fault* is reported to the CPU for each channel. The module can go to a known last state when system power is interrupted. As long as user power is applied to the module, each output will maintain its last value, or reset to zero, as determined by how you have configured the module.

Although you can change the number of actively scanned channels with the Logicmaster 90-30 configurator function, the Hand-Held Programmer does not support editing the number of actively scanned channels. If the 8-Channel Analog Current/Voltage Output module is initialized by a Hand-Held Programmer, the number of actively scanned channels is 8.

If a module had been previously configured with Logicmaster 90-30 software and the number of actively scanned channels has been changed from 8, that number will be displayed on the bottom line of the Hand-Held Programmer display following the AQ entry. You can edit data with the Hand-Held Programmer only for the active channels, but you can not change the number of actively scanned channels.

Module Present

If a module is physically present in a system, it can be added to the system's configuration by reading the module into the configuration file. For example, assume that an 8-Channel Analog Current/Voltage Output module is installed in slot 3 of a Model 311 PLC system. It can be added to the configuration with the following sequence. Use the ↑ and ↓ arrow cursor keys or the # key to display the selected slot.

Initial Display

```

RO:03 EMPTY >S

```

To add the IC693ALG392 module to the configuration, press the **READ/VERIFY, ENT** key sequence. The following screen will be displayed:

```

RO:03 AO 1.00 >S
I16:I_

```

For more information on assigning I/O references, see page 5-10, *Assigning Reference Addresses to I/O Modules*.

Selecting %I Reference

At this point the starting %I reference address for the status data returned from the module must be entered. Notice that the length of the status field (16) is displayed as the first two digits following the first I on the second line of the display.

Note

This field cannot be changed with the Hand-Held programmer. However, it can be changed using the LogiMaster 90-30 software configurator function. The Hand-Held Programmer will always reflect the currently active length of the status field.

Pressing the **ENT** key will allow the PLC to select the starting address of the status data. You can select a specific starting address by pressing the key sequence for the desired address and pressing the **ENT** key. For example to specify the starting address as I17, press the key sequence **1, 7, ENT**. The following screen will be displayed:

```

RO:03 AO 1.00 >S
I16:I0017-I0032

```

You can press the **CLR** key at any time to abort the configuration you have just selected and return the slot to **EMPTY**.

After selecting the starting %I address and pressing the **ENT** key, the following screen appears.

```

RO:03 AO 1.00 >S
AQ8:AQ_

```

Selecting %AQ Reference

This screen allows you to select the starting address for the %AQ reference by specifying the starting reference in the %AQ field. You can select the next available address (the default) or enter a specific address. Pressing the **ENT** key will allow the PLC to select the starting addresses.

To enter a specific address (for example %AQ35), press the starting reference number keys and the **ENT** key. For example, to specify a starting address of %AQ35, press the key sequence **3, 5, ENT**.

```
R0:03 AO 1.00 >S
AQ8:AQ035-AQ043
```

Note that the length of the status field (8) is displayed as the first two digits following the first **AQ** on the second line of the display.

Note

This field cannot be changed with the Hand-Held programmer. However, it can be changed using the Logicmaster 90-30 software configurator function. The Hand-Held Programmer will always reflect the currently active length of the status field.

You can press the **CLR** key at any time to abort the configuration you have just selected and return the slot to **EMPTY**.

Removing Module From Configuration

If required, this module can be removed from the current rack configuration. Assume that the module is currently configured in rack 0, slot 3. It can be deleted with the following sequence:

Initial Display

```
R0:03 AO 1.00 >S
AQ8:AQ_
```

To delete the module, press the **DEL, ENT** key sequence. The display will then be:

```
R0:03 EMPTY >S
```

If the **CLR** key had been pressed after the **DEL** key (instead of the **ENT** key), the delete operation would have been aborted.

Selecting Module Default Mode

The default STOP mode of the module, either HOLD or DEFLOW, can be displayed and modified, if required, by using the following procedure.

```

RO:03 AO 1.00 >S
I16:I0017-I0032

```

To display the module's default STOP mode, press → →. The display will show the current mode of the module. The default mode is **HOLD**.

```

RO:03 AO 1.00 >S
HLS/DEF:HOLD

```

You can toggle between the HOLD and DEFLOW modes by pressing the ± key. The range selected is the one currently displayed.

```

RO:03 AO 1.00 >S
HLS/DEF:DEF LOW

```

When the desired mode for the module is displayed on the screen it can be accepted by pressing the ENT key. To return to the previous screen, press the ← key.

Selecting Output Channel Ranges

The range for each of the 8 channels can be displayed and selected or changed as described below. There are two current and two voltage ranges that can be selected.

Initial Display

```

RO:03 AO 1.00 >S
I16:I0017-I0032

```

To display the channel ranges press → → →. The display will show Channel 1 (or the currently selected channel) and the first available range.

```

RO:03 AO 1.00 >S
CHAN 1: 0 - 10 V

```

You can toggle through the range for each channel by pressing the ± key. Each range will be displayed as shown. Each of the ranges are shown below. The range that will be selected is the one currently displayed.

```
RO:03 AO 1.00 >S  
CHAN 1: -10 - 10
```

```
RO:03 AO 1.00 >S  
CHAN 1:4 - 20 MA
```

```
RO:03 AO 1.00 >S  
CHAN 1:0 - 20 MA
```

When the desired range for the module is displayed on the screen it can be accepted by pressing the ENT key. To return to the previous screen, press the ← key. To view the next channel's range display, press the → key.

```
RO:03 AO 1.00 >S  
CHAN 2: 0 - 10 V
```

Edit this channel's range the same as you did for the first channel. The range of all active channels can be changed in the same manner. Return to the initial display screen by pressing the ENT key or by pressing the ← key until the initial screen is displayed..

Saved Configurations

Configurations that contain an 8-Channel Analog Current/Voltage Output module can be saved to an EEPROM or MEM card and read from that device into the CPU at a later time. MEM cards and EEPROMs containing these configurations can be read into any Release 4 or later Series 90-30 CPU (cannot be read into a Series 90-20 CPU). Refer to Chapter 2 of this manual for detailed information on the Save and Restore operations.

Configuring the Current/Voltage Combination Input/Output Module

The *Analog Current/Voltage Combination Input/Output* module, catalog number IC693ALG442, provides up to 4 differential input current or voltage channels and 2 single-ended output channels with either current loop outputs or voltage outputs. Each channel can be individually configured for the current or voltage range, as applicable, required for your application. All module configuration is done through software, except for a jumper required for selecting the current input mode. All ranges can be configured using either the Logicmaster 90-30 programming software configurator function or the Series 90-30 Hand-Held Programmer.

Note that in this module's description, the module will be referred to simply as the *Analog Combo Module*.

Each analog input is capable of providing five input ranges (two voltage and three current), which are:

- 0 to +10 volts (unipolar) - default range for both input and output channels.
- -10 to +10 volts (bipolar)
- 0 to 20 mA
- 4 to 20 mA
- 4 to 20 mA Enhanced

The default input range is voltage mode 0 to +10 volts (unipolar) with user data scaled so that 0V corresponds to a count of 0 and 10V corresponds to a count of 32000.

Each analog output is capable of providing four output ranges (two voltage and two current):

- 0 to +10 volts (unipolar) - default range for both input and output channels.
- - 10 to +10 volts (bipolar)
- 0 to 20 milliamps
- 4 to 20 milliamps

Although you can change the number of actively scanned channels with the Logicmaster 90-30 configurator function, the Hand-Held Programmer does not support editing the number of actively scanned channels. If the 8-Channel Analog Current/Voltage Output module is initialized by a Hand-Held Programmer, the number of actively scanned channels is 8.

If a module had been previously configured with Logicmaster 90-30 software and the number of actively scanned channels has been changed from 8, that number will be displayed on the bottom line of the Hand-Held Programmer display following the **AQ** entry. You can edit data with the Hand-Held Programmer only for the active channels, but you can not change the number of actively scanned channels.

Module Present

If a module is physically present in a system, it can be added to the system's configuration by reading the module into the configuration file. For example, assume that an 8-Channel Analog Current/Voltage Output module is installed in slot 3 of a Model 311 PLC system. It can be added to the configuration with the following sequence. Use the ↑ and ↓ arrow cursor keys or the # key to display the selected slot.

Initial Display

```

R0:03 EMPTY <S
  
```

To add the IC693ALG442 module to the configuration, press the **READ/VERIFY, ENT** key sequence. The following screen will be displayed:

```

R0:03 AIO 1.00<S
AQ2:AQ_
  
```

For more information on assigning I/O references, see page 5-10, *Assigning Reference Addresses to I/O Modules*.

Selecting %AQ Reference

This screen allows you to select the starting address for the %AQ reference by specifying the starting reference in the %AQ field. You can select the next available address (the default) or enter a specific address. Pressing the **ENT** key will allow the PLC to select the starting addresses.

To enter a specific address (for example %AQ35), press the starting reference number keys and the **ENT** key. For example, to specify a starting address of %AQ35, press the key sequence 3, 5, **ENT**.

```

R0:03 AIO 1.00<S
AQ2:AQ035-AQ036
  
```

Note that the length of the status field (2) is displayed as the first digit following the first **AQ** on the second line of the display.

Note

This field cannot be changed with the Hand-Held programmer. However, it can be changed using the Logicmaster 90-30 software configurator function. The Hand-Held Programmer will always reflect the currently active length of the status field.

You can press the **CLR** key at any time to abort the configuration you have just selected and return the slot to **EMPTY**.

After selecting the starting **%AQ** address and pressing the **ENT** key, the next screen that appears is:

```

R0:03 AIO 1.00<S
AI4:AI_

```

Selecting %AI Reference

This screen allows you to select the starting address for the **%AI** reference by specifying the starting reference in the **%AI** field. You can select the next available address (the default) or enter a specific address. Pressing the **ENT** key will allow the PLC to select the starting addresses.

To enter a specific address (for example **%AI35**), press the starting reference number keys and the **ENT** key. For example, to specify a starting address of **%AQ35**, press the key sequence **3, 5, ENT**.

```

R0:03 AIO 1.00<S
AI4:AI035-AI038

```

Note that the length of the status field (**4**) is displayed as the first digit following the first **AQ** on the second line of the display.

Note

This field cannot be changed with the Hand-Held programmer. However, it can be changed using the Logicmaster 90-30 software configurator function. The Hand-Held Programmer will always reflect the currently active length of the status field.

You can press the **CLR** key at any time to abort the configuration you have just selected and return the slot to **EMPTY**.

After selecting the starting **%AQ** address and pressing the **ENT** key, the next screen that appears is:

```

R0:03 AIO 1.00<S
I24:I_

```

Selecting %I Reference

At this point the starting %I reference address for the status data returned from the module must be entered. Notice that the length of the status field (**24**) is displayed as the first two digits following the first **I** on the second line of the display.

Note

This field cannot be changed with the Hand-Held programmer. However, it can be changed using the Logicmaster 90-30 software configurator function. The Hand-Held Programmer will always reflect the currently active length of the status field.

Pressing the **ENT** key will allow the PLC to select the starting address of the status data. You can select a specific starting address by pressing the key sequence for the desired address and pressing the **ENT** key. For example to specify the starting address as I17, press the key sequence **1, 7, ENT**. The following screen will be displayed:

```
RO:03 AIO 1.00<S
I24:I017-I040
```

You can press the **CLR** key at any time to abort the configuration you have just selected and return the slot to **EMPTY**.

After selecting the starting %I address and pressing the **ENT** key, the following screen appears.

Default Configuration

In addition to configuring the Analog Combo module with Logicmaster 90-30 software or by using the **READ/VERIFY, ENT** key sequence with the Hand-Held Programmer, it can automatically be configured when the PLC creates the default configuration at start-up. Refer to *System Configuration - Default* on page 5-15 for details. The module can *ONLY* be automatically configured when it is physically present in a baseplate.

Removing Module From Configuration

If required, this module can be removed from the current rack configuration. Assume that the module is currently configured in rack 0, slot 3. It can be deleted with the following sequence:

```

R0:03 AIO 1.00<S
AQ2:AQ_

```

To delete the module, press the DEL, ENT key sequence. The display will then be:

```

R0:03 EMPTY <S

```

If the CLR key had been pressed after the DEL key (instead of the ENT key), the delete operation would have been aborted.

Selecting Module Default Mode

The default STOP mode of the module, either HOLD or DEFLOW, can be displayed and modified, if required, by using the following procedure.

```

R0:03 AIO 1.00<S
AQ2:AQ035–AQ036

```

To display the module's default STOP mode, press the → key. The display will show the current mode of the module. The default mode is **HOLD**.

```

R0:03 AIO 1.00<S
HLS/DEF:HOLD

```

You can toggle between the HOLD and DEFLOW modes by pressing the ± key. The range selected is the one currently displayed on the screen.

```

R0:03 AIO 1.00<S
HLS/DEF:DEF LOW

```

When the desired mode for the module is displayed on the screen it can be accepted by pressing the ENT key. To return to the previous screen, press the ← key.

Selecting Output Channel Ranges

The range for each of the output and input channels can be displayed and selected or changed as described below. There are two current and two voltage ranges that can be selected for each channel.

Initial Display (Output Channels)

```

R0:03 AIO 1.00<S
AQ2:AQ035-AQ036

```

To display the output channel ranges press → →. The display will show Channel 1 (or the currently selected channel) and the first available range.

```

R0:03 AIO 1.00<S
CH 1-Q:0-10

```

You can toggle through the range for each channel by pressing the ± key. Each range will be displayed as shown. Each of the ranges are shown below. The range that will be selected is the one currently displayed.

```

R0:03 AIO 1.00<S
CH 1-Q:-10+10

```

```

R0:03 AIO 1.00<S
CH 1-Q:4-20

```

```

R0:03 AIO 1.00<S
CH 1-Q:0-20

```

When the desired range for the module is displayed on the screen it can be accepted by pressing the ENT key. To return to the previous screen, press the ← key. To view the next channel's range display, press the → key.

```

R0:03 AIO 1.00<S
CH 2-Q:0-10

```

Edit this channel's range the same as you did for the first channel. The range of all active output channels can be changed in the same manner. To view the first of the Input channels, press the → key and the following screen is displayed.

Selecting Input Channel Ranges

To display the input channel ranges press → →. The display will show Channel 1 (or the currently selected channel) and the first available range.

```

R0:03 AIO 1.00<S
CH 1-I:0-10
  
```

You can toggle through the range for each input channel by pressing the ± key. Each range will be displayed as shown. Each of the ranges are shown below. The range that will be selected is the one currently displayed.

```

R0:03 AIO 1.00<S
CH 1-I:-10+10
  
```

```

R0:03 AIO 1.00<S
CH 1-I:4-20
  
```

```

R0:03 AIO 1.00<S
CH 1-I:0-20
  
```

```

R0:03 AIO 1.00<S
CH 1-I:4-20+
  
```

When the desired range for the module is displayed on the screen it can be accepted by pressing the ENT key. To return to the previous screen, press the ← key.

Selecting Low and High Alarm limits

To view the alarm limits display, press the → key and the following screen will be displayed.

```

R0:03 AIO 1.00<S
CH 1-I LO: 00000
  
```

This display is the entry field for the *low alarm limit* for this channel. You can enter alarm limit values using the numeric keys (0 through 9) and the ± key for negative values. To accept the value you have entered, or you can press the ENT key or press the ← key to return to the previous screen. To view and make entries for each of the channels, press

the → key until you have viewed the alarm lo limit screen for each channel. Press the → key again to advance to the next alarm limit screen for this channel.

```

R0:03 AIO 1.00<S
CH 1-I HI:+32000

```

This screen shows the entry field for the *high alarm limit* for this channel. You can enter positive or negative integer values using the ± key and the numeric keys. To view the next channel, again press the → key

```

R0:03 AIO 1.00<S
CH 2-I:0-10

```

Edit the alarm limits in the same manner as you did for the first channel. All active channels can be changed with the above key sequences.

Return to the initial display screen by pressing the ENT key or by repeatedly pressing the ← key until the initial screen is displayed..

Freeze Mode

If parameter data is entered to values that are illegal, such as a low limit alarm greater than an upper limit value, or entering a negative alarm for unipolar modes, the module will enter *freeze* mode. This mode will not allow you to exit from the present channel parameters (range, low alarm limit, and high alarm limit) until the illegal condition is removed. If you should press the ← key to go below the range parameter or the → key to try to move past the high alarm limit, the Hand-Held Programmer will stay on those parameters.

If you press the ↑ and ↓ keys to change slots, the screen will display:

```

SAVE CHANGES <S
<ENT>=Y <CLR>=N

```

If you do not want to save the changes to the CPU, press the CLR key, the screen display will then be

```

DISCARDCHANGES<S
<ENT>=Y <CLR>=N

```

If you *do not want to discard the changes* you have made, press the CLR key. This will take you back to the last parameter that was being modified with all changes intact. You can now fix the problem that had caused entry into the freeze mode.

If you *do want to discard the changes* you have made in order to get back to the point you were at before entering the illegal value, press the ENT key. The Hand-Held

Programmer will then return to the last parameter screen with all of the changes reset to what they were before the illegal data was entered.

If, however, at this point you want to save the data to the CPU from the SAVE CHANGES screen shown below

```
SAVE CHANGES <S  
<ENT>=Y <CLR>=N
```

press the ENT key. If there was an illegal value entered, the Hand-Held Programmer will return with a CFG ERR message on the top line of the screen. If all the data is valid, then when you press either the ↑ and ↓ keys, the HHP display will move to the next slot.

Saved Configurations

Configurations that contain Analog Combo modules can be saved to an EEPROM or MEM card and read from that device into the CPU at a later time. MEM cards and EEPROMs containing these configurations can be read into any Release 4 or later Series 90-30 CPU (cannot be read into a Series 90-20 CPU). Refer to Chapter 2 of this manual for detailed information on the Save and Restore operations.

Chapter 6

Program Edit

The Series 90-30/20/Micro Hand-Held Programmer supports four major operating modes. Of these four modes, **Program** mode is used to create, alter, monitor, and debug Statement List (SL) logic programs entered by the user.

***CPU 351 operations.** The only operations supported by the Model 351 CPU in PROGRAM mode are writing to and reading from the user flash memory. You must use Logicmaster 90-30/20/Micro programming software to edit the CPU 351.*

Interaction (Read, Write, and Verify) with an EEPROM or Series 90 Memory Card is also possible in program mode. For information on performing a read, write, or verify operation, please refer to chapter 2, *Operation*.

Program mode allows you to:

- Program a boolean logic, function, or function block instruction.
- Specify a memory reference type.
- Specify an instruction step.
- Specify a decimal (possibly signed) or hexadecimal constant or value.
- Change the display format of a monitored value between signed decimal and hexadecimal.
- Begin an instruction step insertion operation.
- Move between instruction steps.
- Move between function parameters.
- Search for a given target.
- Delete an instruction step.
- Replace an instruction and/or reference with the PLC running.
- Abort or cancel the current operation or user input.
- Check the program for instruction and/or reference usage errors.
- Clear program memory.
- Complete an operation or user input.
- Monitor the execution of a program.
- Write, read, or verify Memory Card or system EEPROM.
- Start or stop the PLC.
- Select an HHP operating mode.

The initial instruction step displayed in program mode is the last one viewed the previous time program mode was selected, since the PLC was powered up. If this is the first time program mode was entered, by default the first instruction step is the initial instruction step displayed:

This chapter describes how to enter program mode and use these features listed above to edit a user logic program.

Entering Program Mode

In order to program the attached programmable logic controller, you must first select the program mode of operation. To select program mode, press the MODE key to display the operating mode selections.

```

- 1, PROGRAM <S
  2. DATA
    
```

Press the 1 key to select program mode or the ENT key since the desired mode (Program) is at the top of the screen.

```

1_ 1. PROGRAM <S
   2. DATA
    
```

Press the ENT key to invoke the new mode. The first screen displayed in program mode is::

```

#0001 <S
<END OF PROGRAM>
    
```

Note

If the OEM key has been activated, you cannot enter program mode. Please refer to chapter 7, *PLC Control and Status*, for additional information on OEM protection.

Keypad Functionality

The following table gives an overview of how the keypad on the Hand-Held Programmer is used in program mode.

Table 6-1. Keypad Functionality in Program Mode

Key Group	Description
LD OUT/OUTM SETM/SET RSTM/RST AND/OR/NOT BLK	Program a boolean logic instruction.
FUNC	Program a function or function block instruction.

Table 6-1. Keypad Functionality in Program Mode - Continued

Key Group	Description
I/AI Q/AQ M/T G/S R	Specify a memory reference type.
#	Specify an instruction step.
0 - 9 -/+ I/A(A) Q/AQ (B) M/T(C) AND(D) OR (E) NOT (F)	Specify a decimal (possible signed) or hexadecimal value. These keys are used to specify the hexadecimal digits A through F.
CLR	Abort or cancel the current operation or user input.
Up and Down cursor keys	Move between instruction steps.
Left and Right cursor keys	Move between function parameters.
ENT	Complete an operation or user input.
INS	Begin an instruction step insertion operation.
WRITE	Write MEM CARD or system EEPROM.
READ/VERIFY	Read or verify MEM CARD or system EEPROM.
SRCH	Search for a given target.
DEL	Delete an instruction step.
RUN	Start or stop the PLC.
MODE	Select an HHP operating mode.

Displaying a Step or Parameter

A single instruction step or function parameter can be viewed on the LCD screen at a time. Four cursor keys allow you to sequentially scroll through an existing statement list program. These keys include the Up (\uparrow), Down (\downarrow), Left (\leftarrow), and Right (\rightarrow) cursor keys.

The Up and Down cursor keys are used to view the next and previous steps, respectively, of the program, from the current instruction step. Function parameters cannot be viewed with these keys.

The Left and Right cursor keys are used to view the next and previous parameters, respectively, of a function. They are *only* valid if the current instruction step is a function. New instruction steps may not be viewed with these keys.

The following example illustrates the use of the cursor keys. A simple ladder logic program is first shown in ladder diagram form, followed by the same program shown in Statement List (SL) form. Examples of using the cursor keys to view elements of this program follow.

Ladder Diagram Representation

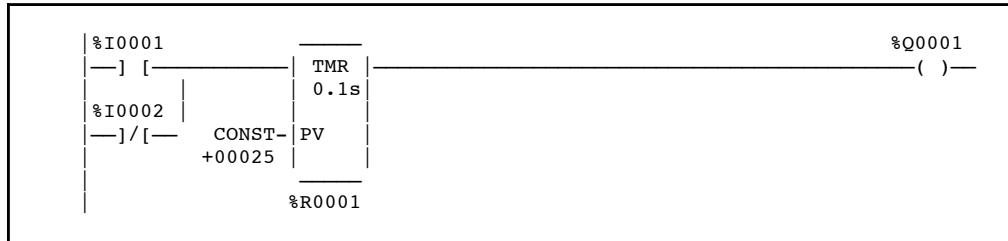

Representation of the Ladder Diagram in Statement List Programming Language

```

#0001:      LD          %I0001
#0002:      OR          NOT %I0002
#0003:      FUNC       10   TMR
                P1:    10
                P2:    25
                P3:    %R0001
#0004:      OUT          %Q0001
    
```

The initial screen on the Hand-Held Programmer displays step 1:

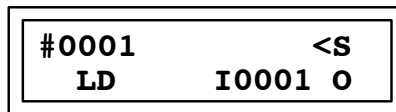

Pressing the Down (-) cursor key displays step 2:

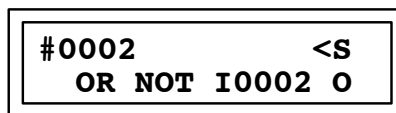

Press the Down (-) cursor key:

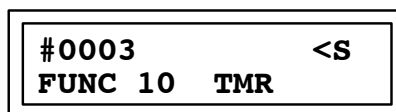

Pressing the Down cursor key again will display the next step of the user program (in this case, step #0004). Pressing the Up cursor key will display the previous step.

Pressing the Right (→) cursor key when step #0003 is displayed on the screen will display the first parameter of instruction step #0003:

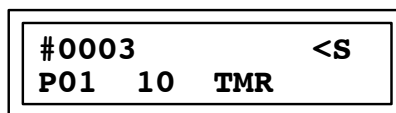

Pressing the Right (→) cursor key again will display the next parameter of this same step. Pressing the Left cursor key will display the previous parameter.

Inserting an Instruction Step

A new instruction step, or series of steps, may be inserted *before* the current instruction step by pressing the INS key. A blank step is displayed, with an underline cursor indicating where to insert the new instruction. New instruction steps may *only* be inserted when the PLC is stopped, as indicated by <S in the upper right corner of the display screen.

To insert a new instruction step, follow this procedure:

1. Use the cursor keys to display the step where the insertion is to occur. If this is the start of a new program, the display screen appears as:



```
#0001          <S
<END OF PROGRAM>
```

2. Press the INS key to enable the insert mode of operation. You may now proceed to insert the new instruction, as described in the following paragraphs.
3. After entering each instruction step or function parameter, press the ENT key to accept it. To complete the insert of the current instruction and continue inserting additional instructions, press the ENT key once. This allows you to remain in insert mode.
4. To complete the insert of the current instruction and then exit insert mode, press the ENT key a second time, with no data entered. This second press of the ENT key allows you to exit insert mode.
5. Press the CLR key to abort insert mode.

Entering an Instruction Type

For each instruction step, you must indicate an instruction type. The instruction type may be either:

- A basic element.
- A standard function.
- A function block.

Refer to the beginning of chapter 9 for a complete listing of the basic elements and standard functions and function blocks of the Statement List (SL) language.

Other guidelines to follow when entering an instruction step include:

After beginning the insert or edit of an instruction, you may decide to abort the current changes. This is done by pressing the CLR key.

1. When entering a reference address, you must enter the reference type first and then the number. For example, to enter the reference address Q12, use the key sequence shown below:



2. When entering a basic element which uses the modifier NOT, BLK, +, or -, the base part of the instruction type must be entered before the modifier. For example, to enter an LD NOT element, you must first enter the base part LD followed by the modifier NOT.
3. When entering a function or function block, the FUNC key must be pressed before entering the function number.
4. When entering a constant parameter, the sign of the number (+ or -) may be entered or toggled either before or after the actual value is entered.
5. When entering a constant parameter, the base of the number (decimal or hexadecimal) may be changed either before or after entering the value by pressing the HEX/DEC key. If the base of the number is changed after entering the value, that value will automatically be converted to the new base when the HEX/DEC key is pressed.
6. When a numeric field portion of an operand *fills up*, additionally entered digits are shifted through the field from right to left, with the leftmost (most significant) digit being lost.

Entering an Operand for a Basic Element

Most instructions require that an operand be provided. For basic elements, this operand would be a reference address for a discrete memory (%I, %Q, %M, %T, %G, %S, %SA, %SB, or %SC). Table 8-2 in chapter 8, *Statement List Programming Language*, lists the valid memory types for the basic elements. The % portion of the discrete memory type is not entered or shown in the display when using the HHP.

Entering an Operand for a Function

For functions and function blocks, the operand may consist of one or more parameters. Each parameter may be a machine reference address or a constant (signed decimal or hexadecimal). In this case, the instruction type must be entered first, and each operand parameter must then be completed, or left unspecified, before the next one is programmed. The description of each function and function block in chapter 8 includes a listing of the valid memory types for each parameter of a particular function or function block.

Replacing an Instruction Step

When inserting or changing an instruction step, you may wish to replace the instruction type, operand, or both. The current instruction step may be edited or replaced by overwriting part or all of the instruction step. Existing instruction steps are normally only replaced when the PLC is stopped, as indicated by <S in the upper right corner of

the display screen. However, a special form of replacement, called substitution change, is supported when the PLC is running.

Note

In order to replace program logic, the access privilege must be level 4 if the PLC is running, or at least level 3 if the PLC is stopped. OEM protection cannot be asserted. If either of these conditions is not met, replacement changes will not be allowed.

To replace or edit the current instruction step, follow this procedure:

1. Use the cursor keys to display the step where the edit is to occur.
2. You may now proceed to edit or replace the instruction, as described in the following paragraphs. The procedure for replacing part of a basic element differs somewhat from that of a function or function block.
3. To complete the replacement of the current instruction, press the ENT key. Replace mode is exited with the just-replaced instruction still displayed.
4. Press the CLR key to abort replace mode.

Replacing Part of a Basic Element

The instruction type of a basic element may be changed any time prior to accepting the instruction step into the rung. If only a modifier, such as NOT or BLK, needs to be added, the base of the instruction type is preserved. To remove a modifier, you must specify the base again. A different base may also be specified, but the modifier is not preserved as part of this replacement.

The reference address operand of a basic element may also be changed any time prior to accepting the instruction step. You may change only the address offset portion of the reference address by pressing only numeric keys. If the memory type indicator is specified again, the address offset portion of the operand is not preserved.

To replace both the instruction type and the reference address operand, each may be replaced individually. Or, you may replace all the current entries for an instruction step at one time by pressing the CLR key.

Boolean Instruction Change

To change the current instruction step from LD I0001 to LD NOT I0001.

The initial display is:

#0003	<S
LD	I0001 O

Press the  key:

#0003	REPLACE <S
LD NOT	I0001 O

Press the  key:

```
#0003      <S
LD NOT I0001 O
```

Reference Address Change

To change the current instruction step from LD I0001 to LD Q0001,

The initial display is:

```
#0003      <S
LD      I0001 O
```

Press the key sequence   :

```
#0003 REPLACE <S
LD      Q 1_ O
```

Press the  key:

```
#0003      <S
LD      Q0001 O
```



Boolean Instruction and Reference Address Change

To change the current instruction step from LD I0001 to LD NOT Q0001,

The initial display is:

```
#0003      <S
LD      I0001 O
```

Press the key sequence

   :

```
#0003 REPLACE <S
LD NOT Q 1_ O
```

Press the  key:

```
#0003      <S
LD NOT Q0001 O
```

Reference Address to Constant Change

To change parameter P01 of the currently displayed instruction step (FUNC 60, ADD) from R0001 to 12,

The initial display is:

```
#0007 ADD <S
P01 R0001 0
```

Press the key sequence 1 2 :

```
#0007 REPLACE <S
P01 12_ 0
```

Press the  key:

```
#0007 ADD <S
P01 12
```

Replacing Functions and Function Block Parameters

Simple replacement changes for function and function block parameters may *only* be performed on the currently displayed parameter. Use the Left cursor key to display the parameter you wish to change. Reference address changes are performed the same as for basic elements, as described in the preceding paragraphs.

If the Left cursor key is pressed when the first parameter is displayed, the function declaration screen is displayed. You may then replace the current function or function block with another one. As long as the new selection is of the same substitution group, the current contents of all parameters are retained. If the new selection belongs to a different substitution group, the contents of the parameters will be lost. (Refer to the information on making on-line changes in this chapter for a listing of the available substitution groups.)

Function Parameter Change



To change parameter P01 of the current function (FUNC 55, GE) from R0001 to R0002:

The initial display is:

```
#0019
FUNC 55 GE <S
```

Press the  cursor key:

#0019 GE	<S
P01 R0001	0

Press the key sequence  and  :

#0019 REPLACE	<S
P01 R 2_	0

Press the  key:

#0019 GE	<R
P01 R0002	0

Function Substitution Change

To change the current instruction step from FUNC 57 GT to FUNC 55 GE,

The initial display is:

#0019	<S
FUNC 57 GT	

Press the key sequence:

FUN	5	5
-----	---	---

#0019	<S
FUNC 55_ GE	

Press the  key:

#0019	<S
FUNC 55 GE	

Deleting an Instruction Step

The current instruction step may be deleted by pressing the DEL key and then the ENT key. All instruction steps beneath the step deleted will scroll up in the program to fill the gap left by the deletion. Note that instruction steps may only be deleted when the PLC is stopped, as indicated by <S in the upper right corner of the display screen.

To delete the current instruction step, follow this procedure:

1. Use the cursor keys to display the step where the deletion is to occur.
2. Press the DEL key to enable the delete mode of operation.

If you press the DEL key only once to enable the delete mode of operation and then press the ENT key, you will delete the current instruction step and terminate the delete mode.

- 3. Press DEL a second time to delete the current instruction step and remain in delete mode after the deletion is completed.
- 4. Press CLR to abort delete mode.

The cursor keys are used to display the step where the deletion is to occur. In this example the element to be deleted is in step #0002.

Initial display:



Press the  key:

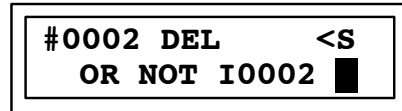

(DEL is blinking)

Press the  key:



Func 10 TMR is the element that was in step #0003 and has now been moved down to step #0002.

Deleting a Program

To clear all of the program logic instruction steps from memory without affecting any other memory, such as data or configuration, press the following keys, in the order shown. When in the program mode of operation the CPU must be stopped.



The CLR key may be used to cancel the memory clear request before pressing the DEL key.

Press the CLR key again to view the last screen displayed before the key sequence was entered to clear program memory.

Searching for an Instruction Element

The search function may be used to search for:

- An instruction.
- An instruction plus reference address.
- A reference address.
- A coil instruction with or without reference address.
- A constant.
- A particular instruction step.

To search for an element, follow this procedure:

1. The search operation is initiated by pressing the SRCH key.
2. Then, identify the element to be searched for (Q12 in example).

```
#0001  SRCH  <S
```

```
#0001  SRCH  <S
        Q12
```

3. Press the ENT key to begin the search operation. The search begins in the forward direction, with the next step or parameter immediately following the current instruction step or parameter. If the <END OF PROGRAM> step is reached before the element is located, the search will wrap to the beginning of the program and continue with instruction step #0001.
4. Use the SRCH and ENT key sequence to search for the next occurrence of the search without specifying a new element to search for.
5. If the search proves unsuccessful, the current instruction step or parameter will remain displayed on the LCD screen, along with a *NOT FND* message:

```
#0003  NOT FND <S
        LD      I0001
```

A search for an instruction step number greater than the number of steps in the program will be successfully completed when the <END OF PROGRAM> step is reached.

6. Press the CLR key to abort search mode.

Assume that the following simple program already exists in the PLC, and that the first step is currently being viewed. Both the Ladder Diagram (LD) and Statement List (SL) forms of the program are given. Examples follow of the usage of the search operation to view this program.

Ladder Diagram Representation

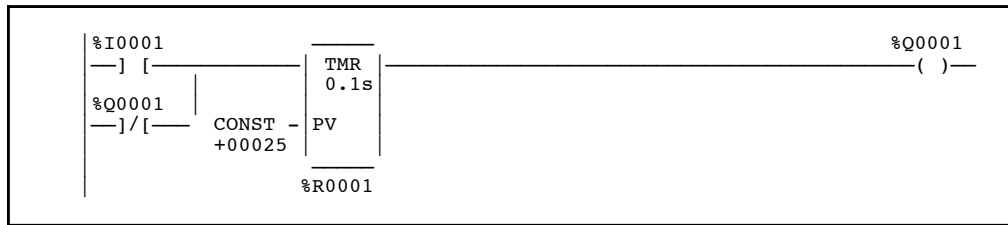

Representation of the Ladder Diagram
in Statement List Programming Language

#0001:	LD		%I0001
#0002:	OR	NOT	%Q0001
#0003:	FUNC	10	TMR
		P1:	10
		P2:	25
		P3:	%R0001
#0004:	OUT		%Q0001

Using the MODE key and the ENTER key go to the Program mode of operation. Also use the RUN key, the +/- key and the ENTER key to be sure the PLC is in the stop mode of operation.

Initial display:

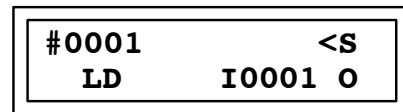

Search For Q1

Press the  key:



Press the key sequence   :

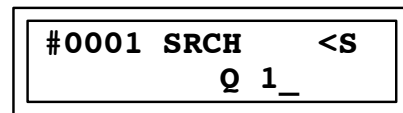

Press the  key:



Press the  :

#0002 <S
_

Press the  :

#0004 <S
OUT Q0001 0

Search for TMR Instruction

Press the  :

#0004 SRCH <S
_

Press the  key:

#0004 SRCH <S
FUNC 10_ TMR

Press the  key:



#0003 <S
FUNC 10 TMR

Search for Instruction OUT with Reference Q1

Press the  key:

#0003 SRCH <S
_

Press the key sequence

  1 :

#0003 SRCH <S
OUT Q 1 _

Press the  key:

```
#0004      <S  
OUT      Q0001 O
```

Search for Instruction Parameter 10

Press the  key:

```
#0004  SRCH  <S  
_
```

Press the key sequence   :

```
#0004  SRCH  <S  
10_
```

Press the  key:

```
#0003  TMR  <S  
P1     10
```



Search for Instruction Step #99

Searching for a step that is beyond the end of the program.

Press the  key:

```
#0003  SRCH  <S  
_
```

Press the key sequence

   :

```
#0003  SRCH  <S  
#99
```

Press the  key:

```
#0005      <S  
<END OF PROGRAM>
```

Note that in the above sequence the pressing of the [SRCH] key is optional. You could have entered only the key sequence [#] [9] [9] [ENT] and achieved the same result. Also, when searching for a timer, the TMR key toggles between TMR and ONDTR.

Wildcard Coil Search

A special “wildcard” coil search operation may also be performed. The coil search operation will locate the next coil instruction (optionally with a reference address modifier), regardless of the coil type (OUT, OUTM, OUT NOT, OUTM NOT, SET, SETM, RST, RSTM, OUT+, OUT-).



The wildcard search is initiated by pressing the SRCH key twice before specifying the type of search to be performed. Then, follow the search procedure described above, beginning with step 2.

Search for Coil Instruction and Reference Address

Using the sample program used in the previous search examples.

Press the  key: #0005 SRCH <S
_

Press the  key: #0005 COIL SR <S
_

Press the key sequence   : #0005 COIL SR <S
Q 1_

Press the  key: #0004 <S
OUT Q0001 O

Search for Coil Instruction

Press the  key: #0005 SRCH <S
_

Press the  key: #0005 COIL SR <S
_

Press the  key:

#0004	<S
OUT	Q0001 O

Monitoring Program Execution

The value associated with an instruction parameter reference address may be monitored while viewing the program logic. Three display formats are supported:

1. Boolean for discrete instructions.
2. Signed decimal for function parameters.
3. Hexadecimal for function parameters.

Note

A double precision signed decimal format is not supported for parameters of Double Precision Arithmetic functions. Only the low word of the double precision value is monitored in signed decimal format.

Data values are monitored both when the PLC is running and when it is stopped. Data values monitored in program mode cannot be changed; changes must be made in data mode. Please refer to chapter 6, *Reference Tables*, for more information on changing data values.

When viewing a contact which represents an internal or external device the power flow indicator displayed is for the condition of the element displayed on the screen.

Boolean No Power Flow Display

#0005	<S
LD	I0001 O

The O in the lower right position indicates no power flow through Input 1.

Boolean Power Flow Display

#0017	<S
LD NOT S0001	■

The block indicates power flow through S0001. Note that this is a NOT contact, S0001, thus there is power through this element.

Signed Decimal Word Display

```
#0033  ADD  <R  
P1 R0001  716
```

Hexadecimal Word Display

```
#0044  AND  <S  
P1 R0012  3E16H
```

Pressing the HEX/DEC key when viewing a function parameter enables you to toggle between hexadecimal and signed decimal format. If you display a different parameter or function after changing the display format and then redisplay the first parameter or function, the new display format will still be used. After power down or when transitioning from run to stop, stop to run, the display will return to default display.

Initial display:

```
#0059 SUB  <R  
P2      65
```

Decimal Display

Press the  key:

```
#0059 SUB  <R  
P2  0041H
```

Hexadecimal Display

Please refer to appendix D for a listing of the default display formats for each function parameter.

Making On-Line Changes

The PLC must be in Protection Level 4 to make On-Line changes.

A limited number of changes may be made to the user logic program when the PLC is running. Normally, only changes which are simple byte-for-byte substitutions that do not change the size of the program are supported.

1. To begin an on-line change, you must first be in replace mode with the PLC running. Once the change is begun, data monitoring of that instruction step is *not* performed.
2. Use the cursor keys to display the step where the edit is to occur.
3. You may now proceed to edit or replace the instruction.
4. Press the ENT key to complete the on-line change.
5. Press the CLR key to abort replace mode, or if an error is made.

Valid On-Line Changes

The following table lists programming functions by groups. The groups listed below indicate what parts of an instruction step may be legally changed in an on-line substitution. Note that on-line changes may occur *only* within the same group; changes cannot be made across groups. Multiple changes within the same instruction step are supported.

Table 6-2. On-Line Substitution Groups

Function Group	Function Group
Reference address	Function 61 (DPADD)
Decimal constant	Function 63 (DPSUB)
Hexadecimal constant	Function 65 (DPMUL)
	Function 67 (DPDIV)
LD	Function 69 (DPMOD)
LD NOT	
	Function 22 (BITSET)
AND	Function 24 (BITCLR)
AND NOT	
	Function 86 (PIDISA)
OR	Function 87 (PIDIND)
OR NOT	
	Function 60 (ADD)
OUT, OUTM	Function 62 (SUB)
OUTNOT	Function 64 (MUL)
OUTM NOT	Function 66 (DIV)
OUT+, OUT-	Function 68 (MOD)
	Function 101 (SREQB)
Function 15 (UPCTR)	Function 105 (SRNEB)
Function 16 (DNCTR)	Function 109 (SRLTB)
	Function 113 (SRLEB)
Function 23 (AND)	Function 117 (SRGTB)
Function 25 (OR)	Function 121 (SRGEB)
Function 27 (XOR)	
	Function 102 (SREQW)
Function 30 (SHL)	Function 106 (SRNEW)
Function 31 (SHR)	Function 110 (SRLTW)
	Function 114 (SRLEW)
Function 32 (ROL)	Function 118 (SRGTW)
Function 33 (ROR)	Function 122 (SRGEI)
	Function 103 (SREQI)
Function 52 (EQ)	Function 107 (SRNEI)
Function 53 (NE)	Function 111 (SRLTI)
Function 54 (LE)	Function 115 (SRLEI)
Function 55 (GE)	Function 119 (SRGTI)
Function 56 (LT)	Function 123 (SRGEI)
Function 57 (GT)	
	Function 104 (SREQDI)
Function 72 (DPEQ)	Function 108 (SRNEDI)
Function 73 (DPNE)	Function 112 (SRLTDI)
Function 74 (DPLE)	Function 116 (SRLEDI)
Function 75 (DPGE)	Function 120 (SRGTDI)
Function 76 (DPLT)	Function 124 (SRGEDI)
Function 77 (DPGT)	

Program Syntax Errors

Program syntax errors are those errors which the system detects in user-provided data. They may be caused by an illegal sequence of otherwise valid individual instructions. Any Statement List program which passes the program check can be translated into relay ladder diagram form.

Typical examples of these errors include:

- JUMP, MCR, or END MCR nesting errors.
- The use of more than 256 total JUMP and MCR functions.
- The placement of an ENDSW function within a JUMP or MCR range.
- Incorrect instruction sequences.
- The dual use of %Q or %M references, if the dual use checking configuration parameter is disabled at the time the instructions are entered. (This prompts a warning only.)
- Corrupted memory (unknown instructions).

The program check function automatically scans for these errors whenever the operating state of the PLC is changed from stopped to running. Please refer to chapter 7, *PLC Control and Status*, for additional information on stopping and starting the PLC. Chapter 9, *Error Messages*, provides a listing of possible non-system errors and their corrective action.

To begin the program check function, enter the following key sequence, in order, while in the program mode of operation and when the CPU is in STOP.



The program check function always begins at the start of the program and stops with the first error found. Chapter 9 describes the corrective action to take for each non-system error. If no errors are found, the current instruction step remains displayed and no message is displayed.

The program check function is automatically performed before writing a program to EEPROM or memory card, and before a LOAD operation is performed by Logicmaster 90 software. If a non-system error is detected, the program header is marked to indicate that error.

Aborting the Insert/Edit Operation

After beginning the insert or edit of an instruction, you may decide to abort the current changes. This is done by pressing the CLR key.

Press the CLR key once to erase the current instruction entry and remain in insert mode.

Press the CLR key a second time to abort the insert operation. All instructions beginning with the next instruction step are scrolled up one instruction step in the program.

If you had just begun the insert operation and no data was currently entered on the screen, only a single press of the CLR key would be required.

Completing the Insert/Replace Operation

When all the necessary information has been entered as part of an insert or replace operation, the operation may be completed by pressing the ENT key. The ENT key functions differently depending on whether the operation was to insert or replace.

To complete the insert of the current instruction and continue inserting additional instructions, press the ENT key once. This allows you to remain in insert mode.

To complete the insert of the current instruction and then exit insert mode, press the ENT key a second time, with no data entered. This second press of the ENT key allows you to exit insert mode.

To complete the replacement of the current instruction, press the ENT key. Replace mode is exited with the just-replaced instruction still displayed.

When you press the ENT key to accept an instruction, the instruction is checked in its entirety to ensure that the instruction is correct and that all required operands have been specified. For functions, only the current parameter is checked. Any constant, reference address, or function number present is checked to ensure that it falls into the range of acceptable values. An "INS ERR" message will be displayed if any errors are found.

Exiting Program Mode

To exit the program edit function, press the MODE key. The mode selection screen will be displayed.



Chapter 7

Reference Tables

The Reference Table function (data mode) enables you to view and change the contents of data tables within the PLC. You can also change the format of the display to better reflect the numerical base and type of the data items.

The following tables can be accessed from within the Reference Tables function:

- Discrete inputs (%I)
- Discrete outputs (%Q)
- Internal coils (%M)
- Temporary coils (%T)
- Discrete globals (%G)
- System status references (%S, %SA, %SB, and %SC)
- Analog inputs (%AI)
- Analog outputs (%AQ)
- Register references (%R)
- System register references (%SR)

This chapter describes how to enter the data mode of operation and how to view and/or change the contents of data tables within the programmable controller.

Entering Data Mode

In order to display the data tables, you must first select the data mode of operation.

1. To select data mode, press the MODE key to display the operating mode selections.

```
  1. PROGRAM <S  
  2. DATA
```

2. Press the 2 key to select data mode.

```
2_ 1. PROGRAM <S  
   2. DATA
```

- Press the ENT key to invoke the new mode. The first screen displayed in data mode will be:

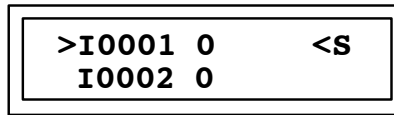

Upon entering this function, the display defaults to what was displayed the last time the reference tables function was selected, since the PLC was powered up. If this is the first time data mode was entered, the discrete inputs (%I) table is displayed. %I0001 is the topmost reference displayed, and binary is the display format.

Keypad Functionality

The following table gives an overview of how the keypad on the Hand-Held Programmer is used in data mode.

Table 7-1. Keypad Functionality in Data Mode

Key Group	Description
TMR/ONDTR UPCTR/DNCTR	Change display format to timer / counter; automatically select register table if not displayed.
I/AI Q/AQ M/T G/S R	Specify a memory reference type.
HEX/DEC	Change display format between binary, signed decimal, and hexadecimal.
0 - 9 -/+ I/A(A) Q/AQ (B) M/T(C) AND(D) OR (E) NOT (F)	Specify a binary, decimal (possible signed) or hexadecimal value. These keys are only used for specifying the hexadecimal digits A through F.
CLR	Abort or cancel the current operation or user input.
Up and Down cursor keys	Move view window around currently displayed table.
Right cursor key	Invoke a reference table contents change.
Left cursor key	Abort a reference table contents change.
#	Override, or cancel the override, on a discrete reference.
ENT	Complete an operation or user input.
RUN	Start or stop the PLC.
MODE	Select an HHP operating mode.

Display Format

A number of display formats may be encountered, depending on which table is displayed.

Discrete Reference Tables

The discrete reference tables %I, %Q, %M, %T, %G, %S, %SA, %SB, and %SC each support three possible display formats, when in data mode, as shown below.

Table 7-2. Screen Format of a Discrete Reference Table in Binary Format

>	Top Reference		Binary 0/1		PLC State
>	Bottom Reference		Binary 0/1		

Table 7-3. Screen Format of a Discrete Reference Table in Signed Decimal Format

>	Top Reference		Signed Decimal -32768 ... 32767		PLC State
	Bottom Reference		Signed Decimal -32768 ... 32767		

Table 7-4. Screen Format of a Discrete Reference Table in Hexadecimal Format

>	Top Reference		Hexadecimal 0000...FFFF	H	PLC State
	Bottom Reference		Hexadecimal 0000...FFFF	H	

Top Reference: The top reference field indicates the address of the current reference address. Only the data value of the top reference can be changed.

PLC State: The PLC state field indicates whether the PLC is currently stopped or is running (executing a program). A leading < character, followed by an **S** if the PLC is stopped or **R** if it is running, indicates the state of the PLC.

Bottom Reference: The bottom reference field indicates the address of the second item in the data table which can be viewed.

Binary Field: The binary field contains the data value associated with a reference address, with a display format of single-bit binary.

Signed Decimal: The signed decimal field contains the data value associated with a reference address, with a display format of 16-bit signed decimal.

Hexadecimal: The hexadecimal field contains the data value associated with a reference address, with a display of 16-bit (4-digit) hexadecimal.

Register Reference Tables

The register reference tables %R, %AI, %AQ, and %SR each support three common display formats when in data mode. Two of these, signed decimal format and hexadecimal format, are exactly like those detailed above for the discrete tables. The third, binary format, is different than the binary format for the discrete tables. For register tables, the binary field contains a data value with a display format of 16-bit binary. The screen format is as follows.

Table 7-5. Screen Format of a Register Table in Binary Format

>	Top Reference		PLC State
Binary 16 {0/1}			

In addition, the %R table supports an additional display format, timer/counter. The timer/counter display format is useful as a timer/counter access function. This screen format is shown below:

Table 7-6. Screen Format for Viewing a %R Table in Timer/Counter Format

Timer/Counter		Top Reference		EN 0/1		Q 0/1		PLC State
Preset Value -32768 ... 32767			Current Value -32768 ... 32767					

EN: The EN field indicates the current state of the enable bit within the timer/counter control word. It will be either a 1 (enabled) or a 0 (not enabled).

Q: The Q field indicates the current state of the output bit within the timer/counter control word. It will be either a 1 (indicating timing or counting completion has occurred) or a 0 (indicating timing or counting completion has not occurred).

Preset Value: The preset value field indicates the preset value currently applied to the timer or counter. It will be a signed decimal number.

Current Value: The current value field indicates the current, or elapsed, value currently extracted from the timer or counter. It will be a signed decimal number.

Error Messages

Error messages are displayed in a window on the screen which overlays the currently displayed information. The original information is redisplayed when the next key is pressed.

Table 7-7. Screen Format for Displaying Messages in Binary Format

>	Top Reference	Message	PLC State

Table 7-8. Screen Format for Displaying Messages in Signed Decimal and Hexadecimal Format

>	Top Reference	Message	PLC State
	Bottom Reference	Signed Decimal -32768 ... 32767	

Table 7-9. Screen Format for Displaying Messages in Timer/Counter Format

T/C		Top Reference		EN	0/1	Q	0/1	PLC State							
Preset Value -32768 ... 32767				Message											
1	2	3	4	5	6	7	8	9	10	11	12	13	14	15	16

Changing the Format of a Display

The HEX/DEC, TMR/ONDTR, and UPCTR/DNCTR keys are used to change the format of a display. The current display format (binary, signed decimal, or hexadecimal) is maintained when changing the display to view a different reference table. The exception to this is when changing from the display of the %R table in timer/counter format to another table, or when remaining in the %R table and pressing the HEX/DEC key. In these cases, the display format is returned to what it was before the TMR/ONDTR or UPCTR/DNCTR key was pressed.

Changing the Format of a Discrete Reference Table

The following example illustrates how to change the format of a discrete reference table:

1. After entering data mode, use the Down cursor key to display %I0022 as the top reference displayed. The initial display format is single-bit binary.

<div style="display: flex; justify-content: space-between;"> >I0022 0 <S </div> <div style="margin-left: 20px;">I0023 0</div>

2. Press the HEX/DEC key to change the display format to signed decimal. Note that %I0022 is no longer the top reference displayed; it has been replaced as the top reference by %I0017 because all word-sized data (signed decimal and hexadecimal) is word-aligned within a discrete memory table on a multiple of sixteen points boundary.

```

>I0017      0  <S
I0033      0
    
```

3. Press the HEX/DEC key again to change the display format to hexadecimal.

```

>I0017  0000H <S
I0033  0000H
    
```

4. Pressing the HEX/DEC key a third time will return the display format to single-bit binary. However, %I0017 is retained as the top reference, instead of restoring the original top reference to %I0022.

Changing the Format of a Register Reference Table

The following example illustrates how to change the format of a register reference table.

1. From the last discrete reference table screen in the previous example, enter the key sequence R, 1 and press the ENT key. The %R reference table is displayed in 16-bit binary form, with %R000I the top reference displayed.

```

>R0001      <S
0000000000000000
    
```

2. Press the HEX/DEC key to change the format to signed decimal:

```

>R0001      0  <S
R0002      0
    
```

3. Press the HEX/DEC key again to change the format to hexadecimal:

```

>R0001  0000H <S
R0002  0000H
    
```

4. Pressing the HEX/DEC key a third time returns the display format to 16-bit binary.

```

>R0001      <S
0000000000000000
    
```

- 5. Press the TMR/ONDTR/ or UPCTR/DNCTR key to change the format to timer / counter:

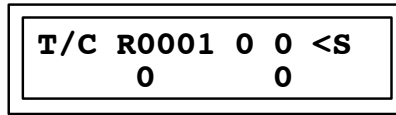

- 6. Press the HEX/DEC key to return to 16-bit binary display again.

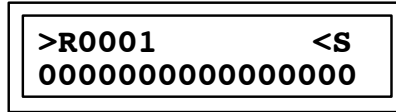

Selecting a Different Top Reference

There are several ways to select a different top reference on the display screen.

The Up and Down cursor keys can be used to scroll the top reference within the current table. For example, if the %I reference table is currently being displayed in single-bit binary form and %I0022 is the top reference displayed, pressing the Down cursor key will select %I0023 as the top reference. Moving the cursor beyond the upper or lower boundary of a table causes the display to wrap. Both the highest and lowest references in the table will be simultaneously displayed.

Another way of selecting a different top reference is by typing in a new reference address, for any table, and then pressing the ENT key. If the reference address specified exceeds the limits of the table, the last reference in that table will be selected as the top reference.

The TMR/ONDTR and UPCTR/DNCTR keys can be used to select the %R table in timer / counter format from any reference table.

The CLR key can be used to abort a request to change the top reference on the display screen and remain on the current display.

Changing Table Data

The value of the top reference selected can be changed to another value. This change can occur regardless of whether the PLC is stopped or is running, provided that you have the proper access privilege for writing to data memory. Without the correct privilege, your request to initiate a data table change will be denied. The **PROTECT** message will be displayed when the ENT key is depressed and the data table change is attempted. (Refer to chapter 7, *PLC Control and Status* for additional information on obtaining the proper access privilege through protection mode.)

Any value entered as a change is restricted to the current data format. For example, if the display format is signed decimal, you can enter a change only as a signed decimal value. A hexadecimal value could not be entered. In register reference tables (%R, %AI, and %AQ) with a current display format of 16-bit binary, a data value change must be entered in hexadecimal.

When attempting to modify a boolean value, only the digits 0 and 1 are valid. If you try to enter any other digit, the key will be ignored; no message will be displayed. To correct this unsuccessful attempt, either specify a valid boolean value or press the CLR key to abort the change.

When attempting to modify a signed decimal value, the valid range is between -32,768 and +32,767, inclusive. If you try to enter a value which is not in this range, the request will be rejected. Again, to correct this unsuccessful attempt, either specify a valid value or press the CLR key to abort the change.

In the %R reference table, with timer/counter as the display format, data value changes are restricted to the preset register only. A change to the preset value will be retained only if -1 has been specified for the preset parameter or -1 in the register specified for holding the preset variable of the associated timer/counter function block. Please refer to section 1 of chapter 8 for additional information on timers and counters.

The following example illustrates how to change the value of the top selected reference:

1. Assume that the %I reference table is currently displayed and that %I0022 is the top reference. The display format is single-bit binary:

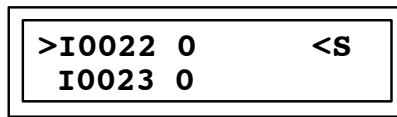

2. Press the Right cursor key:

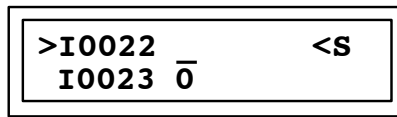

The blinking _ (underscore) character on the display screen indicates that a new data value can be entered for the top reference displayed.

3. Press the 1 key:

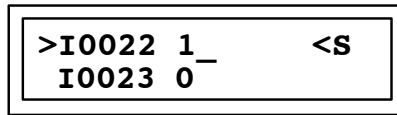

4. Press the ENT key:

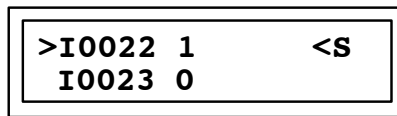

The data value of %I0022 has now been changed from 0 to 1.

Canceling a Data Value Change Operation

To completely abort a data change operation that has already been started, press the Left cursor key to immediately terminate the change. The data value change operation is immediately aborted, and the original data value is restored.

To continue with a data change operation, but erase the change value typed in so far, press the CLR key. The data value which has already been typed in is erased, but the data change operation is still active.

Pressing the CLR key a second time, with no data value currently typed in, will abort the data change operation. This is the same as using the Left cursor key, described above, to abort the data value change operation.

Overriding a Discrete Reference











In the Model 331, 340, 341, and 351 CPUs, a discrete reference within the %I, %Q, %M, or %G table (top reference only) can be overridden, regardless of whether the PLC is stopped or is running. (This function is *not* available in the Series 90-30 Model 311 or Model 313 CPU, or the Series 90-20 Model 211 CPU). An override may be invoked *only* if the current data format is binary, and if the proper privilege level is accessed. Once it is overridden, you can still change the reference's contents, as previously described.

With the reference you wish to override displayed as the top reference, press the # key to invoke the override. The data value of the reference blinks to indicate that the reference is now overridden. This override condition is maintained whether or not the reference is displayed on the screen. To cancel the override, press the # key again with the overridden reference displayed as the top reference.

Clearing a Data Table

The Reference Tables function enables you to clear an entire data table, initializing the contents of that table to all zeros (0). In order to clear a table, the PLC must be in stop and data mode.

1. Press the key which corresponds to the type of data table you wish to clear.

To Clear This Table	Press the Following Key(s)
%I data table:	press 
%Q data table:	press 
%M data table:	press 
%G data table:	press 
%T data table:	press  
%AI data table:	press  
%AQ data table:	press  
%R data table:	press 

2. Press the following key sequence:



3. Press the  key.

Note

When clearing one of the data tables %I, %Q, %M, or %G, the overrides associated with the table being cleared are automatically removed.

The following example illustrates how to clear a register (%R) table when in the Data Mode and initialize its contents to all zeros.

The initial display appears as:

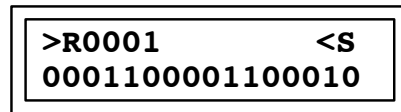

Press the  key:

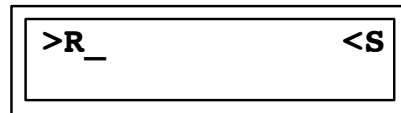

Press the key sequence

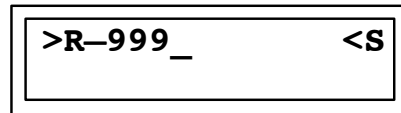
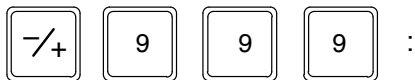

Press the  key:

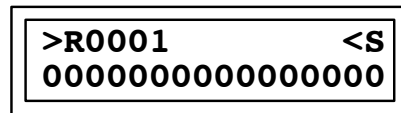

The CLR key can be used to cancel the clear request anytime before the DEL key is pressed.

Clearing all Overrides

An input (%I) or output (%Q) status table, a discrete global (%G) table, or an internal coil (%M) table can be cleared of all overrides when the PLC is stopped. The procedure is the same as described above for clearing a data table and initializing its contents to all zeros, except that the # key is added to the sequence of keys to press. Press the key that corresponds to the type of data table you wish to clear, then press:

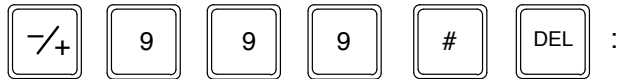

Viewing Special System Registers

A special view-only reference table is supported as part of the Reference Tables function. This table, known as the System Registers (%SR) table, contains information about certain PLC operating parameters. Interaction with this table is identical to that of the standard register (%R) table, except that timer / counter display format is not valid, table value changes are not allowed, and System Register 15 (Program Memory Available) is always displayed in decimal.

The system register definitions are listed in the following table, along with the display format required for proper viewing.

Table 7-10. Special System Registers

Reference	Display Format	Description
%SR001	Hexadecimal	Type of PLC.
%SR002	Hexadecimal	Revision code of the PLC's firmware.
%SR003 - %SR006	Hexadecimal	Encoded form of level 2 password.
%SR007 - %SR010	Hexadecimal	Encoded form of level 3 password.
%SR011 - %SR014	Hexadecimal	Encoded form of level 4 password.
%SR015	Signed decimal	User program memory still available.
%SR016	Signed decimal	Current scan time of the PLC in milliseconds.

The following example illustrates how information about the PLC operating parameters can be obtained from the special system registers.

1. Assume that the %I table is displayed in binary mode, as shown below.

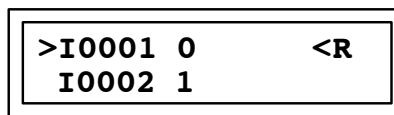

2. Press the key sequence G/S,G/S,R, 1 to view system register %SR001:

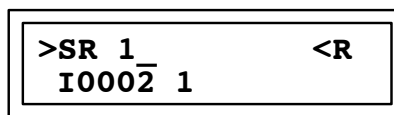

3. Press the ENT key:

```

SR001          <R
0011010100000000
  
```

4. Press the key sequence HEX/DEC, HEX/DEC. From this screen, you can determine the CPU model number and firmware revision code. In the following example screen, the CPU is a Model 311 (0331 would be displayed for a Model 331, etc.) and the firmware revision code is 01.10.

```

>SR001  0311H <R
SR002  0110H
  
```

5. Press the Down cursor key twice to display system registers SR003 and SR004. From this screen, you can view the first two words of the encoded password for level 2.

```

>SR003  E0DDH <R
SR004  3D98H
  
```

6. Pressing the Down cursor key twice again will display the last two words of the encoded password for level 2 (SR005 and SR006). Subsequent presses will display the first two words (SR007 and SR008) or the last two words (SR009 and SR010) of the level 3 password, and the first two words (SR011 and SR012) or the last two words (SR013 and SR014) of the level 4 password.
7. Press the – cursor key twice to display system registers SR015 and SR016. Press the HEX/DEC key twice to change the display from hexadecimal to decimal. From this screen, you can determine the amount of program memory available for additional logic and the current scan time. In this example, the attached PLC still has 5000 bytes of (one word of user program memory is two bytes) user program memory available for additional logic, and its current scan time is 54 milliseconds.

```

>SR015  5000 <R
SR016  54
  
```

Exiting Data Mode

To exit the reference table function, press the MODE key. The mode selection screen will be displayed.



```

1. PROGRAM <S
2. DATA
  
```

Chapter 8

PLC Control and Status

Protection mode enables you to control access to various functions of the programmable controller. You can restrict others from changing (or, in some cases, even viewing) program logic, configuration data, reference data, subroutines, and the protection levels themselves. Four levels of user passwords are provided for PLC protection; provisions for setting, displaying, changing, or deleting them are supported. Also, a software lock can be applied to individual subroutines. An additional feature, OEM protection, is also supported. *OEM protection supersedes user specified protection.*

This chapter describes how to change the current access level, display and modify passwords, and use the OEM protection feature.

Protection Levels

The first of the following tables identifies the protection available at each of the four levels of user password protection capabilities. Note that Level 1 access is always available; it can not be password protected. Levels 2, 3, and 4 can all be password protected to prevent unauthorized access to certain functions.

The second table shows how access to the different functions is modified when the OEM level of protection is engaged. Note that in the OEM protection mode the end user's privileges of reading or writing to (viewing and changing) the logic program are taken away.

Table 8-1. Password Protection*

Level	Program		Data		Configuration		Passwords	
	Run	Stop	Run	Stop	Run	Stop	Run	Stop
4	R/W	R/W	R/W	R/W	R	R/W	R/W	R/W
3	R	R/W	R/W	R/W	R	R/W		
2	R	R	R/W	R/W	R	R		
1	R	R	R	R	R	R		

* Not OEM protected (OEM key unlocked).
R = Read privilege; W = Write privilege.

Table 8-2. OEM Protection

Level	Program		Data		Module Configuration		Passwords	
	Run	Stop	Run	Stop	Run	Stop	Run	Stop
4			R/W	R/W	R	R	R/W	R/W
3			R/W	R/W	R	R		
2			R/W	R/W	R	R		
1			R	R	R	R		

R = Read privilege; W = Writeprivilege.

The actual access availability to the different functions of the programmable controller at a given time is governed by the last level which was viewed on the HHP screen. This availability of access level can automatically change when disconnecting the Hand-Held Programmer from the programmable controller, or by cycling power on the PLC. In either case, the access level is returned to a default level. If the programmable controller is not password protected (all levels have a NULL password), this default level will be level 4. If the PLC is password protected (at least one level has a password other than NULL), this default level will be one level less than the lowest numbered level which is password protected. For example, if levels 4 and 3 are password protected, level 2 would be the default access level. When displaying a level of access, that level can be toggled between the users mode and the OEM mode only if the OEM password is known. When the level of access is in the OEM protection mode the letters OEM will be displayed on the screen. See the section on screen displays and locking & releasing OEM protection for more information.

Entering Protection Mode

When protection mode is selected, the initial screen is dependent on the current level of access privilege.

1. To select the protection mode, press the MODE key to display the operating mode selections. The _ and 1 will be blinking.



2. Press the 3 key to select protection mode.



3. Press the ENT key to enter the new mode.

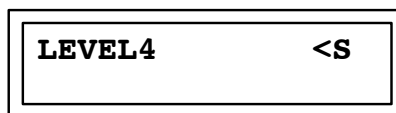

If the programmable controller is not password protected, the initial screen will show level 4, the default level, if no passwords have been set.

If the programmable controller is password protected and the access level has not been changed since the Hand-Held Programmer was attached to the PLC or since the PLC was last powered up, the initial screen will show the lowest level not password protected. Remember that the level viewed on the screen last or the default level is the one that is enabled at a given time.

If the programmable controller is password protected but the access level has been changed, the initial screen will show the last level you specified access for.

To move to another level of access from the one presently displayed the up/down cursor keys are used. To display a higher level of privileges the password for that level must be known. No password is needed to move the display to a lower level of access from the one presently displayed. (See the section on changing the users access level.)

Password Enable and Disable Configuration

One of the parameters associated with the configuration of the CPU while in the CPU configuration mode of operation is whether to enable or disable the password protection capabilities of the CPU. When set for disable no passwords can be set. The default state for password protection is enable.

Note

If one or more access levels is currently password protected, you cannot disable the password protection feature. All levels of protection (level 2, 3, 4) must have the Null password in it.

To disable passwords, follow this procedure:

1. Starting in the configuration mode on the HHP and looking at Rack 0 slot 0 (for the Model 311 and Model 313) and (Rack 0, Slot 1 for Model 331, Model 340, Model 341, and Model 351). Use the right arrow key to advance to the password enable and disable screen. The initial display screen shows that passwords are enabled.

```

RO:01 PLC    <S
PASSWRD: ENABLE

```

2. Press the -/+ key, the display will toggle to password disable.

```

RO:01 PLC    <S
PASSWRD: DISABLE

```

3. Press the ENT key

```

RO:01 PLC    <S
<ENT>=Y <CLR>=N

```

4. Since password protection cannot be easily re-enabled, this screen will prompt you to confirm the request to disable it.

5. Pressing the CLR key cancels the disable request, and no change will occur. Pressing the ENT key confirms the request, and password protection will be disabled.
6. If you attempt to re-enable password protection on this screen by pressing the -/+ key again, the request will be denied and an error message will be displayed.

**RO:01 PROTECT <S
PASSWRD: DISABLE**

The same error message will be displayed if you attempt to later password protect any access level through the protect mode function.

Once the system has been configured to disable passwords, they can only be re-enabled by clearing the PLC's memory through a power cycle. To do this, press the CLR and M/T keys simultaneously (see Table 2-5) while the PLC is powering-up.

Keypad Functionality

The following table gives an overview of how the keypad on the Hand-Held Programmer is used in protection mode.

Table 8-3. Keypad Functionality in Protection Mode

Key Group	Description
0 - 9 I/A(A) Q/ Q (B) M/T(C) AND(D) OR (E) NOT (F)	Specify a 1 to 4 digit hexadecimal password value. Hexadecimal letter (A to F) is in upper left corner of designated key
CLR	Abort or cancel the current operation or user input.
Up cursor key	Enter lower access level.
Down cursor key	Enter higher access level.
Right cursor key	Display password for lower access level.
Left cursor key	Display password for higher access level; view / modify OEM key.
DEL	Delete password at specified access level.
ENT	Complete an operation or user input.
RUN	Start or stop the PLC.
MODE	Select an HHP operating mode.

Moving to another level of access

Two different screen formats are used to change the current access level, one which shows the current access level and a second screen format for specifying a higher access level. Both of these screen formats are shown below.

Table 8-4. Current Access Level

L E V E L	Level #	unused	OEM Protection	unused	PLC State
unused					

Table 8-5. Higher Access Level

L E V E L	Level #	unused	OEM Protection	unused	PLC State
P S W	Level #	unused	:	Password	unused

Level #: The level # field indicates a password level. Its value can range between 1 and 4, inclusive.

OEM Protection: The OEM protection field indicates whether or not OEM protection has been activated. This field will be blank if OEM protection has not been activated; it will contain the indicator *OEM* if it has been activated.

PLC State: The PLC state field indicates whether the PLC is currently stopped or is running (executing a program). A leading < character, followed by **S** if the PLC is stopped or **R** if it is running, indicates the state of the PLC.

Password: The password field is where you input a 1 to 4 hexadecimal digit password corresponding to a given access level. Four hexadecimal digits provide 65,536 unique passwords. The same password can be used for more than one level; passwords do not have to be unique. The specification of leading zeros is significant; 12, 012, and 0012 are different passwords.

The Up and Down cursor keys can be used to display a lower or higher access level, respectively. For example, if the current access level is 4 and you wish to change this to 2, you would press the Up cursor key twice and then press the ENT key to accept the change. However, since this is a change to a lower level, you do not have to specify the password for level 2 in order to make the desired change.

Initial display:

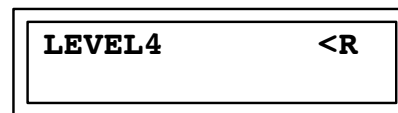

Press the key:

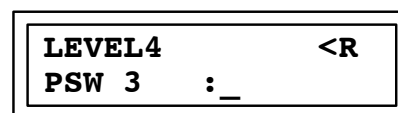

Press the  key:

```
LEVEL4      <R  
PSW 2      :_
```

Press the  key:

```
LEVEL4      <R  
PSW 2      :_
```

To change to a higher level, you must specify the password for the higher level in order to make the desired change. For example, if the current access level is 1 and you wish to change this to 3, you would press the Down cursor key twice and then enter the password. If the password for level 3 is A5A5, you would press the key sequence I/ AI, 5, I/ AI, 5 and then press the ENT key. If the wrong password is entered, or no password is entered at all, the access change request will be refused and a *DATA ER* message will be displayed. If the correct password is known, specify it correctly and attempt the level change again. Otherwise, press the CLR key to abort the change.

Initial display:

```
LEVEL1      <R
```





Press the  key:

```
LEVEL1      <R  
PSW 2      :_
```

Press the  key:

```
LEVEL4      <R  
PSW 2      :_
```

Press the key sequence

    :

```
LEVEL1      <R  
PSW 3      :A5A5_
```

Press the  key:

```
LEVEL3      <R
```

It is possible that the higher access level which you wish to invoke is not password protected. The PLC can not be password protected at all. In this case, the reserved

password which indicates a NULL password, should be specified. The NULL password is specified when ENT is pressed while the password field is empty.

The CLR key can be used to cancel the access level change prior to activating it. If a password is currently specified, pressing the CLR key will only erase the current user input. Pressing the CLR key a second time cancels the operation. If no user input has been specified when the CLR key is pressed the first time, only a single press of the CLR key is required to cancel the operation.

Displaying and Modifying Passwords

Passwords can be displayed and modified *only* if level 4 access has been gained by displaying level 4 on the screen and is being displayed on the screen. If you attempt to view passwords without level 4 access, your request will be refused and a *PROTECT* message will be displayed.

When the Level 4 access is displayed on the screen the right cursor key is used to display the password for level 4. Repeated presses of the right cursor key will display the password for levels 3 and 2. When reviewing levels 2 or 3, while in Level 4 mode of protection, and it is desired to display a password belonging to a higher Level, use the left cursor key.

When displaying a password, the actual password will be shown if one exists. If a password does exist it can be changed or deleted. If the indicated level is not password protected, the designation *NULL* will be shown instead. In such a case, a password can then be set, if desired. Whenever you attempt to assign a password to a particular level, the password must be specified first. Otherwise, the assignment is refused and a *DAT ERR* message will be displayed. You must specify the desired password before pressing the ENT key to activate.

The following screen format is used to view and modify passwords:

Table 8-6. Specify/Change Password for Specified Level

L	E	V	E	L	Level #	unused	OEM Protection	unused	PLC State
S	E	T	unused	Level #	unused	:	Password	unused	

In the following example, level 4 is password protected with password 1234, level 3 is not password protected, and level 2 is password protected with password 0AB1. Follow this procedure to assign the password 0AB1 to level 3 instead of level 2, and remove the password from level 2.

- The initial display screen shows level 4 as the current access level:

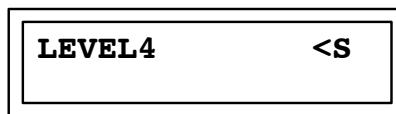

- Press the Right cursor key three times to display the level 2 password:

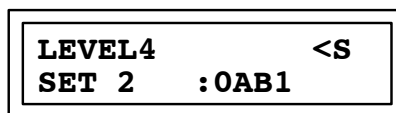

3. Press the DEL key and then the ENT key to delete the level 2 password:

```

LEVEL4      <S
SET 2      :NULL
    
```

At this point, the password assigned to level 2 has been successfully deleted. The deletion of a password affects only that password; no other level's password is affected. A password for level 3 can now be assigned.

4. Press the Left cursor key to display the level 3 password:

```

LEVEL4      <S
SET 3      :NULL
    
```

5. Press the keysequence I/AI,Q/AQ, 1; then, press the ENT key:

```

LEVEL4      <S
SET 3      :0AB1_
    
```

Alternatively, you could have assigned password 0AB1 to level 3 first and then deleted the password from level 2. Passwords for different levels do not have to be unique.

Canceling a Password Change

The CLR key may be used to cancel a password change prior to activating it (pressing the ENT key). If a password is currently specified, pressing the CLR key will only erase the current user input. Pressing the CLR key from any screen while viewing passwords returns the user to the display of the current access level.

Pressing the CLR key a second time cancels the operation. If no user input has been specified when the CLR key is pressed the first time, only a single press of the CLR key is required to cancel the operation.

Locking and Releasing OEM Protection

OEM protection is a level of security intended for OEM use, as opposed to the normal four levels of passwords which are intended for end-user use. With OEM protection locked (enabled), the privilege versus protection level table is modified as shown below (refer to Table 7-2). Note that both read and write privileges are *lost* to the end-user.

The following screen format is used to lock and release OEM protection:

Table 8-7. Lock and Release OEM Protection

L	E	V	E	L	Level #	unused	OEM Protection	unused	PLC State
O	E	M	K	E	Y	:	OEM Key	unused	

The OEM key field contains a 1 to 4 hexadecimal digit password which controls OEM protection. Four hexadecimal digits provide 65,536 unique passwords. The same password can be used for more than one level. OEM passwords can also be used as user passwords; they do not have to be unique. The specification of leading zeros is optional; 12, 012, and 0012 all refer to different passwords. Zero counts as part of the password.

The Left cursor key enables you to lock or release OEM protection from any password access level. When the Left cursor key is pressed, the system prompts you for the OEM key. If correctly entered, the current status of OEM protection (locked or released) will be toggled. If currently locked, it will be released; if currently released, it will be locked. If the wrong OEM key is entered, or no key is entered at all, the lock or release request will be refused and a *PSWERR* message will be displayed. If the correct key is known, enter it correctly and attempt the lock or release request again. Otherwise, press the CLR key to abort the request. Assume that the OEM key is 1234 and OEM level is locked and it is to be unlocked in Mode 3 (protect) mode, and access Level 3.

Initial display:

```
LEVEL3  OEM  <S
```

Press the  key:

```
LEVEL3  OEM  <S
OEM KEY: _
```

Press the key sequence

    :

```
LEVEL3  OEM  <S
OEM KEY: 1234_
```

Press the  key:

```
LEVEL3  <S
```

Note that OEM protection, which had been locked, is now released. IF it is desired to lock OEM protection again, the exact same sequence shown above would be followed.

Canceling an OEM Protection Operation

The CLR key can be used to cancel the OEM protection lock/release operation prior to activating it. If an OEM key is currently specified, pressing the CLR key will only erase the current user input. Pressing the CLR key a second time cancels the operation. If no user input has been specified when the CLR key is pressed the first time, only a single press of CLR key is required to cancel the operation.

Displaying and Modifying the OEM Key

The OEM key can be displayed and modified *only* if level 4 access has been gained *and* OEM protection is currently released. If you attempt to view an OEM key with OEM

protection locked, the request will be refused and a *PROTECT* message will be displayed. The same error message will be displayed if you attempt to view an OEM key from any access level other than 4.

When displaying the OEM key, the actual password will be shown if one exists. If a password does exist, it can be changed or deleted. If the OEM key does not exist, the designation *NULL* will be shown instead. In such a case, a password can be set, if desired. Whenever you attempt to assign an OEM key, the OEM key must be specified first. Otherwise, the assignment is refused and a *DATA ER* message will be displayed.

It is up to the OEM to lock OEM protection after programming a new key to protect against the key being viewed or modified. Before you lock OEM protection, however, the OEM key must first be set. (The *NULL* key *0000* is not valid as a key specification.) Otherwise, the lock request is refused.

The following screen format is used to display and modify the OEM key:

Table 8-8. Specify/Change OEM Key

L	E	V	E	L	Level #	unused	OEM Protection	unused	PLC State
S	E	T		K	E	Y	:	OEM Key	unused

In the following example, the current access level is level 4 and an OEM key has not yet been set. Follow this procedure to establish FEDC as the OEM key and then lock OEM protection.

1. The initial display screen shows level 4 as the current access level:

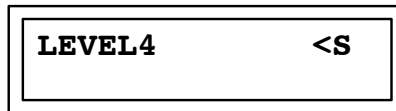

2. Press the Left cursor key; the system will prompt you for the OEM key:

Press the  key:

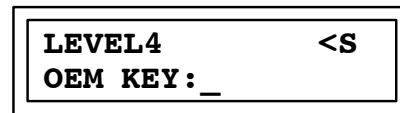



3. Since OEM protection is not currently locked, and level 4 access has been achieved, you can view the current OEM key. Press the Left cursor key again.

Press the  key:

LEVEL4 <S
SET KEY: NULL

Since no OEM key has ever been specified, *NULL* is displayed to signify the absence of a key.

4. Press the following key sequence to enter the OEM key; then, press the ENT key:



 :

LEVEL4 <S
SET KEY: FEDC

At this point, the OEM key has been set, but OEM protection has not been locked.

5. To initiate the lock operation, press the Right cursor key to display the previous screen:

Press the  key:

LEVEL4 <S
OEM KEY: _

6. From this screen, you can lock OEM protection by entering the key sequence of the OEM key and pressing the ENT key.

Removing OEM Protection

The OEM key can be removed when OEM protection is no longer required. In order to delete an existing OEM key, it must first be displayed, as described in the previous example. Once displayed, press the DEL and ENT keys to remove the key.

Canceling an OEM Key Change

The CLR key can be used to cancel an OEM key change prior to activating it. If an OEM key is currently specified, pressing the CLR key will only erase the current user input. Pressing the CLR key a second time cancels the operation. If no user input has been specified when the CLR key is pressed the first time, only a single press of CLR key is required to cancel the operation.

Reading EEPROM, Memory Card, or Flash Memory With an OEM Key

When an EEPROM, Memory Card, or flash memory is read into the PLC and the saved configuration contains an OEM key, the OEM protection will be **AUTOMATICALLY** locked after a successful read.

Subroutine Protection Levels

Series 90-30 Release 3.0, provides an additional level of program logic protection to control view and edit access to individual subroutines (subroutines are not supported in the Series 90-20 PLC). Two types of subroutine locks are available: VIEW, in which zooms are disabled for a locked subroutine, and EDIT, in which the information in a locked subroutine can not be altered. The Hand-Held Programmer allows you to display the subroutine protection status.

Note

Setting and modifying of subroutine lock passwords, and locking and releasing of subroutines can only be done with Logicmaster 90-30/20/Microsoftware.

User specified protection of the PLC program applies to all subroutines within the program. Subroutine Protection, however, provides you with a means to limit access at the subroutine level without locking the entire program. For example, if the PLC is not password protected and OEM protection is disabled, any subroutine in the program could be view-locked or edit-locked through Logicmaster 90-30/20/Micro without affecting view or edit access to the remainder of the program logic.

Display of Subroutine Protection Status

The protection status of each subroutine is displayed in the Subroutine Declaration List which exists in the Subroutine Declaration submode. View-locked and edit-locked subroutines appear in the list with a lower case **v** or **e**, respectively, following the subroutine number (for example, #0002vSUBR 02, #0003eSUBR 03). Subroutines for which protection has been released appear in the list with a blank following the subroutine number.

Attempt to Zoom Into a View-Locked Subroutine

There are two ways that you can to zoom into a subroutine. The first is from the Subroutine Declaration List and the second is from a Subroutine Call Function. If the desired subroutine is view-locked, the zoom will not be permitted and an error message will be displayed.

Zoom From the Subroutine Declaration List

The following example shows how to enter the Subroutine Declaration mode.

Press the  key:



Press the  key:

```

_ 1. MAIN   <S
  2. SUBR

```

Next, cursor down to SUBR.

Press the  key:

```

_ 2. SUBR   <S

```

Then, to enter the Subroutine Declaration mode:

Press the  key:

```

#0001 NO SUBR <S
#0002 NO SUBR

```

You are now in Subroutine Declaration mode where declarations of up to 64 subroutines can be viewed. To locate the desired subroutine declaration, use the ↑ or ↓ key, or the # key with the desired subroutine number. At this point, use the # and ⇨ keys to zoom into the desired subroutine. If the subroutine is view-locked, an error message is displayed.

Note

In this case, you must first unlock the subroutine or change its locked status to edit-locked using Logicmaster 90-30/20/Micro software before you can zoom into the program statement list.

The following screen will appear when you attempt to zoom into view-locked subroutine 01.

Press the key sequence   :



```

#0001 vPROTECT <S
#0002 SUBR02

```

Zoom From a Subroutine Call Function

If you cursor to the Subroutine Call Function and attempt to zoom into the subroutine

logic by entering the   keys and the subroutine is view-locked, the *PROTECT* error message is displayed.

Note

You must use Logicmaster 90-30/20/Micro software to unlock the subroutine or change its locked status to edit-locked in order to zoom in.

Attempt to Make Changes to Edit-Locked Subroutine

If you zoom into an edit-locked subroutine from either the Subroutine Declaration List or a Subroutine Call Function, any attempt to change the statement list instructions will cause the *PROTECT* error message to be displayed.

Note

The subroutine must be unlocked using Logicmaster90-30/20/Micro software before any editing within that subroutine will be permitted.

Deletion of a Locked Subroutine

There are no restrictions against the deletion of a locked subroutine or a program containing a locked subroutine. As described in *Entering Subroutines* in Chapter 9, a subroutine can only be deleted if the program contains no CALLs to that subroutine.

Program Check

If an error is detected by program check within a view-locked subroutine, only the entry for that subroutine in the Subroutine Declaration List is displayed. No zoom into the subroutine's statement list will occur.

Chapter 9

Statement List Programming Language

This chapter does not apply to the Model 351 CPU. Logicmaster90-30/20/Micro programming software must be used to program the Model 351 CPU.

The Statement List programming language allows you to implement any *well-formed* Boolean equation as a sequence of contacts and coils. This chapter defines the basic elements, functions, and function blocks which you can use to program an attached Series 90-30 PLC, Series 90-20 PLC, or Series 90 Micro PLC.

Relay Ladder Logic

The basic programming structure of a programmable controller is relay logic. The ladder logic is made up of a group of logic elements called rungs.

The relay ladder rungs, as drawn on paper, have two sides; with contacts, function blocks (function blocks explained later in this chapter), and coils connecting the two sides together. The left side is called the power bus simulating the L1 side of the power line. This is the starting side and usually has input coils and coil contacts attached to it. The right side is the side of this logic group and usually has outputs and coils attached to it. Contacts are basic symbols used to represent conditions to be evaluated in order to determine the control of an output coil. Each contact and coil has a label attached to it which identifies the external or internal device that it represents. This label is also the programmable controllers internal storage location for storing the conditions of this contact or coil.

A contact may represent the status of an external push button attached to an input to the PLC. If this was the first input to the PLC, the contact would normally be labeled I0001. I for input and 0001 for the number of the input it represents. A contact can also represent the status of an internal or external output coil. In this case it would have the same label as the coil. Coils are usually labeled with a Q for an external (real world) coil or an M for an internal memory coil. This Q or M is followed by a number which is the number of the coil being represented. The I, Q, and M also represent the internal location where the status of the contact or coil is stored in the memory of the programmable controller.

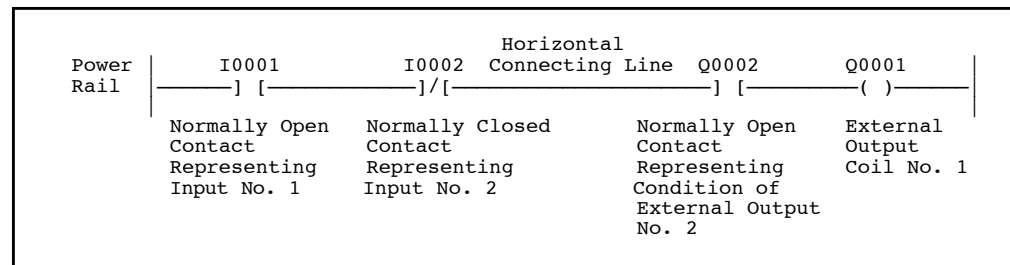

A ladder rung is built by connecting the contacts in series and parallel combinations to form sequences of logic. Contacts connected in series are said to be *ANDed* together and those that are connected in parallel are said to be *ORed* together. These contacts are of two types; normally open and normally closed, similar to that of a mechanical relay.

A normally open contact will pass power from its left side to its right side when the device it represents is on (passing power or current). A normally closed contact will pass power from its left side to its right side only when the device it represents is off (has no current flow or no power flow). When this normally closed contact is connected in series with another contact it is said to be NOT ANDed, and when it is connected in parallel it is said to be NOT ORed.

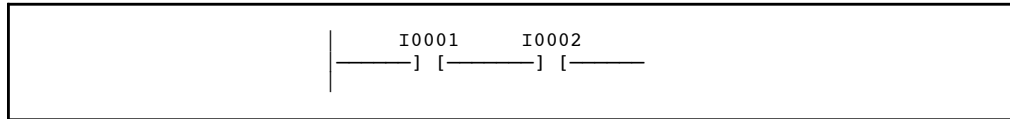

Two Normally Open contacts in Series

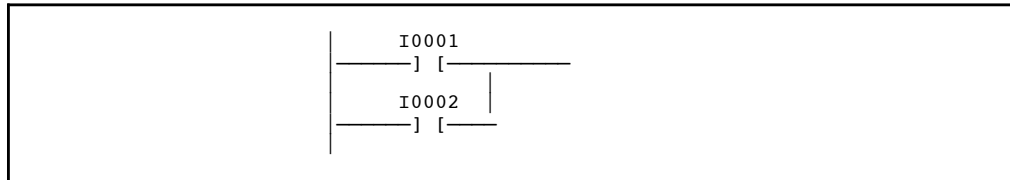

Two Normally Open contacts in Parallel

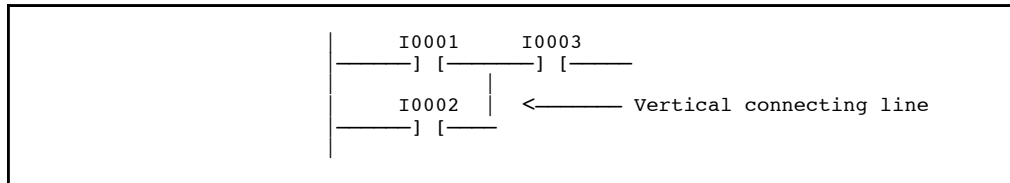

Combination of Series and Parallel Contacts

When there is continuous current flow or power is passed through a continuous line of connected contacts starting at the power rail and traveling towards the right to the coil at the end of this rung of logic, the coil will turn on. Power flow only travels from left to right through contacts and horizontal connecting lines. On vertical connecting lines power flow can travel in either direction top to bottom or bottom to top.

The Statement List is a mnemonic form used to enter the ladder logic program using the Hand Held Programmer (HHP). The instructions AND, OR, NOT AND, NOT OR, LOAD, OUT, etc. along with input and output address are used to place the program logic into the programming memory of the Central Processing Unit (CPU).

The following table lists all of the basic elements that you can use when programming in the Statement List Language.







Table 9-1. Statement List Language Basic Elements

Graphic	Symbol	Description	KeySequence	Operation
LD		Normally open contact, start of sequence		A normally open contact acts as a relay that passes power flow if the associated reference is ON (1).
LDNOT		Normally closed contact, start of sequence		A normally closed contact acts as a relay that passes power flow if the associated reference is OFF (0).
LD BLK	not applicable	Mark a point within a rung		Set a marker at a point within an incomplete rung. After a subsequent OUT BLK instruction is executed, additional logic will begin at the marked position.
AND		Normally open contact, continue series sequence		Add a normally open contact in series with the previous contact.
AND NOT		Normally closed contact, continue series sequence		Add a normally closed contact in series with the previous contact.
AND BLK		AND two blocks of serial logic		AND together the current logic block with the last block saved using the LD BLK function.
OR		Normally open contact, continue parallel sequence		Add a normally open contact in parallel with the previous contact.
OR NOT		Normally closed contact, continue parallel sequence		Add a normally closed contact in parallel with the previous contact.
OR BLK		OR two blocks of parallel logic		OR together the current logic block with the last block saved using the LD BLK function.

Table 9-1. Statement List Language Basic Elements - Continued

Graphic	Symbol	Description	KeySequence	Operation
OUT	-()-	Non-retentive coil with normally open contacts		The coil sets a discrete output ON while it receives power flow. It is non-retentive.
OUTM	-(M)—	Retentive coil with normally open contacts		The retentive coil sets a discrete output ON while it receives power flow. The state of the retentive coil is retained across power failure.
OUT NOT	—(/)—	Non-retentive coil with normally closed contacts		The negated coil sets a discrete output ON when it does not receive power flow. It is not retentive.
OUTM NOT	—(/M)—	Retentive coil with normally closed contacts		The negated retentive coil sets a discrete output ON when it does not receive power flow. The state of the negated retentive coil is retained across power failure.
SET	—(S)—	Non-retentive set latch coil		When a set coil receives power flow, its reference stays ON (whether or not the coil itself receives power flow) until it is reset by power flow to a reset coil. The set coil is non-retentive.
SETM	—(SM)—	Retentive set latch coil		The retentive set coil sets a discrete output ON if the coil receives power flow. The output remains ON until reset by a reset coil. The state of the retentive coil is retained across power failure or when the PLC transitions from stop mode to run mode.
RST	—(R)—	Non-retentive reset latch coil		The reset coil sets a discrete machine output or internal output OFF if the coil receives power flow. The output remains OFF until reset by a set coil. The reset coil is non-retentive.
RSTM	—(RM)—	Retentive reset latch coil		The retentive reset coil sets a discrete machine output or internal output OFF if it receives power flow. The output remains OFF until set by a retentive set coil. The state of this coil is retained across power failure or when the PLC transitions from stop mode to run mode.

Table 9-1. Statement List Language Basic Elements - Continued

Graphic	Symbol	Description	KeySequence	Operation
OUT+	—(↑)—	OFF-ON transitional coil (one shot) on power flow	 	If the output associated with a positive transition coil is OFF, when the coil receives power flow it will be set to ON for one sweep. This coil can be used as a one-shot.
OUT—	—(↓)—	ON-OFF transitional coil (one shot) on no power flow	  	If the output associated with this coil is OFF, when the coil stops receiving power flow, the reference will be set to ON for one sweep.
OUT BLK		Return to previous LD BLK marker	 	Return the logic to a point within the rung marked by the LD BLK instruction.

Entering a Program

When entering a program each of the basic symbols contacts, coils, and function blocks are entered into program memory locations called steps. Each step has a number starting with one at the beginning of the program and incrementing in sequential order until the last element in the program has been entered.

When the CPU solves the logic it starts at step one and proceeds sequentially to the highest step number then starts over (see Chapter 2 in the Series 90-30 PLC Reference Manual, GFK-0467, for more information).

For each instruction step you will need to indicate an instruction type. This can be a basic element or a standard function block i.e.: AND, OR, Function 10, etc. Also a companion operand, in most cases, must be provided. For a basic element this operand would be the discrete memory type (I, Q, M, T, G, S, SA, SB, SC) followed by its reference numbered address location within this memory type. In the case of a function block the operand would be one or more parameters. Each parameter could be an internal CPU reference address or a constant.

The following table lists the allowable memory types for the basic elements listed in the previous table.

Table 9-2. Allowable Memory Types for Basic Elements

Instruction	%I	%Q	%M	%T	%G	%S	%R	%AI	%AQ	Constant
LD	•	•	•	•	•	•				
LD NOT	•	•	•	•	•	•				
LD BLK										
AND	•	•	•	•	•	•				
AND NOT	•	•	•	•	•	•				
ANDBLK										
OR	•	•	•	•	•	•				
OR NOT	•	•	•	•	•	•				
OR BLK										
OUT		•	•	•						
OUTM		•	•		•	•†				
OUT NOT		•	•	•						
OUTM NOT		•	•		•	•†				
SET		•	•	•						
SETM		•	•		•	•†				
RST		•	•	•						
RSTM		•	•		•	•†				
OUT+		•	•	•	•	•†				
OUT—		•	•	•	•	•†				
OUT BLK										

† Only %SA, %SB, and %SC are used. %S cannot be used.

Guidelines for Entering Programs

Several rules and guidelines which should be followed when entering new rungs, elements of logic, or when modifying an existing program are listed below:

1. Entering new logic or modifying old logic:
 - For new logic the CPU must be in the stop mode and the HHP must be in the Program and Insert mode.
2. When programming an element the following order of programming must be followed:
 - First, enter the element type, that is, AND, OR, OUT, etc.
 - Second, enter the discrete memory type: I, Q, M, T, G, S, SA, SB, SC.
 - Third, enter the numerical address (reference) within the memory type.
 - Fourth, press the ENTER key to place the element into the program memory of the CPU.

3. The first element of a rung must always be a serial contact off of the left power bus. The element type will be LD or LD NOT. Elements may then be placed in parallel or series with this first element.
4. The last element in a rung must be a coil, except when CEND, NOOP, and ENDSW are used and when power flow from a function block is not needed.
5. When using the Hand-Held Programmer there is no restriction as to the number of parallel contacts that can be placed across a single contact. The same is true for contacts being placed in series. However if the Logicmaster 90 method of programming is to be used to view, monitor or modify the program, there are the following restrictions:
 - Only eight (8) parallel contacts are allowed. The number of contacts or group of parallel contacts that can be placed in series is restricted to nine (9).
6. Functions cannot have contacts or other functions placed in parallel with them.
7. All functions except CEND, LABEL, ENDMCR, NOOP, and ENDSW must have control logic programmed before it in a rung. Thus functions cannot be programmed to the power rail or be the first element in a rung.

Entering Subroutines

Subroutines can be included in a statement list program to enhance the overall operation of your Series 90-30 PLC system (*subroutines cannot be included in a Series 90-20 PLC program*). In order to enter a subroutine, you must define the subroutine. To do this, first enter Program Mode. Once you are in Program Mode, you then enter a sub-mode which is where you do the actual subroutine definition. To access the Subroutine Declaration mode, use the following procedure:

Initial display after pressing the MODE key:

```

_ 1. PROGRAM <S
  2. DATA
  
```

Press the  key :

```

_ 1. MAIN <S
  2. SUBR
  
```

At this point, press the ENT key again to enter Program Mode to access the Main program or cursor down to SUBR and press the ENT key to enter the Subroutine Declaration mode.

Press the  key :

```

_ 2. SUBR <S
  
```

Press the  key :



```
#0001 NO SUBR <S
#0002 NO SUBR
```

You are now in the Subroutine Declaration mode where declarations of all 64 possible subroutines can be viewed. You can view these declarations by using the \leftarrow or \rightarrow keys, or the # key with a subroutine number key sequence following it.

Once the subroutines have been viewed, you can then enter the # and \uparrow keys to zoom into the desired subroutine and declare it. Once the subroutine is declared, you can zoom out of the subroutine by entering the # and Z keys to return to the Subroutine Declaration level. Use the following key sequence to declare the subroutine.

Initial display:

```
#0001 NO SUBR <S
#0002 NO SUBR
```

Press the key sequence   :

```
#0001 S01 <S
<END OF SUBR>
```

You can now enter instructions for the selected subroutine. For example, to define a subroutine with the following statement list program:

```
#0001: LD NOT %I0001
#0002: OUT %Q0001
```

Enter the following key sequences:



Initial display:

```
#0001 S01 <S
<END OF SUBR>
```

Press the key sequence  :

```
#0001 INS S01 <S
```

Press the key sequence



    :

```
#0001 S01 <S
LD NOT I 1_
```

Press the  :

```
#0002 INS S01 <S
_
```

Press the key sequence

   :

```
#0002 INS S01 <S
OUT Q 1_
```



Press the  key:

```
#0003 INS S01 <S
_
```

Press the  key:

```
#0003 S01 <S
<END OF SUBR>
```

You can now zoom out of the subroutine to define other subroutines or to return to the main program definition. To zoom out of a subroutine, and return to the subroutine declaration list, enter the following key sequence:

Press the key sequence   :

```
#0001 SUBR 01 <S
#0002 NO SUBR
```

If you have accessed the subroutine from a Subroutine Call Function in other subroutines, use of the zoom out key sequence, as shown above, will return you one call level at a time. If you have accessed the subroutine from a Subroutine Call Function in the Main program, the key sequence #, #, Z will return you to the location of that Call in the Main program. Otherwise, this key sequence will return you to the Declaration Level in Subroutine Mode where you had first zoomed into a subroutine.

If you are at the subroutine declaration level already, you can either declare additional subroutines using the above method, cursor up or down to subroutines that are already declared and zoom into them for editing, zoom back to the main program Call Subroutine Function by entering the #, Z key sequence, or return to Program Mode by pressing the MODE key.

Subroutine Deletion

In order to delete an existing subroutine from the program, you must be at the subroutine declaration level (using the key sequence described above). Once in the Subroutine Declaration level, you can cursor to the subroutine being deleted and enter the DEL, ENT key sequence. Subroutines that are called in the main program or in other subroutines cannot be deleted. If this is attempted, an error will be detected by the program check and the error message USE ERR will be displayed on the HHP screen.

Subroutine Zoom

The subroutine statement list program can be viewed with the HHP in Program Mode. To view the subroutine statement list instructions, cursor to the Subroutine Call Function and zoom into the subroutine logic by pressing the # Z keys. To zoom out of the current subroutine program, press the # Z keys. If subroutine calls are nested within each other, these keys will let you access the calls one level at a time. If at any time, you want to return to the top level of the subroutine call in the main program, enter the key sequence # # Z .

Error Display

The following error conditions will be detected and result in messages displayed on the HHP screen:

- There are a maximum of 64 subroutine declarations. The message DATA ERR will be displayed on the HHP if an attempt is made to call a subroutine number exceeding 64.
- There is a total of 16K bytes of user program memory available for each subroutine logic block. The message MEM OVR will be displayed if the remaining user program memory is exceeded.
- Nested subroutine calls are allowed with 8 nesting levels. This will be checked at run-time and a fault will be logged if the nesting level of 8 is exceeded. The fault to be logged will be in fault group APPLICATION FAULT, and the error code is app_stack_overflow. This fault is non-fatal, and the PLC will go to STOP Mode when the fault is logged. If you have exceeded the subroutine nesting limit and are zooming down through the CALLSUB instructions, you will receive a NEST ERR message when you attempt to zoom into the ninth subroutine in the call sequence.
- A subroutine call cannot be connected directly to the power rail. If this is done, the error message SEQ ERR will be displayed on the HHP screen.
- If the 64 Call instruction limit per logic block is exceeded, the error message CAL OVR will be displayed.

Impact on Other PLC Functions

The use of subroutines will have the following impact on PLC operation.

- A Read or Write operation to / from EEPROM / MEMCARD is not allowed when in Subroutine Declaration Mode.
- A Search operation will search the current block (i.e., main program block or current subroutine block) that is being edited or viewed. Program check will check the entire program including all subroutine blocks.
- A Read / Write EEPROM / MEMCARD will read / store the entire program including all subroutine blocks.

How to Enter a Logic Element Using the HHP

In order to program the attached PLC, you must first select the program mode of operation. When selecting the program mode of operation, the initial instruction step displayed is the last one viewed the previous time that program mode was selected, since the PLC was powered up. If entering program mode for the first time, by default the first instruction step is treated as the initial instruction step to be displayed.

In the following example, assume that you are viewing a reference table, and wish to select the program mode of operation. Further assume that you have not entered the program mode since the PLC was last powered up, that there is no program in the CPU, and there is no OEM protection and that you have at least level 3 access of availability. If the following screen is displayed while attempting to enter your logic it means that your system is password protected and you should refer to Chapter 8 for more details.

Initial display:

```
#0001 PROTECT <S
LD      I0001 O
```

Press the  key:

```
>R0001 0000H <S
R0002 0000H
```

("_1." is blinking)

```
1_1. PROGRAM <S
2. DATA
```

Press the  key:

```
1_1. PROGRAM <S
2. DATA
```

("_1." is blinking)

The following screen is not valid with a Series 90-20 PLC system.

Press the  key:

```
1_1. MAIN <S
2. SUBR
```

("_1." is blinking)

Press the  key:

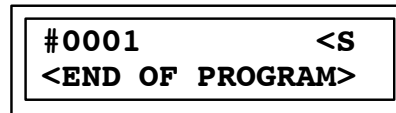

("_ 1." is blinking)

If <R is displayed instead of <S it means that the CPU is in the Run Mode. If this is the case use the following procedure to put the CPU into the STOP mode. Otherwise skip to: "Enter the Insert Mode of Operation".

Press the  key:

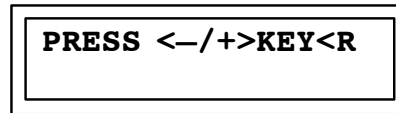

The -/+ key is used to toggle between the "RUN MODE" and "STOP MODE" states. Pressing the -/+ key initially selects "RUN MODE".

Press the  key:

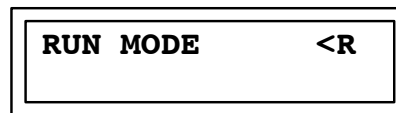

Pushing the —/+ key toggles the selection to "STOP MODE".

Press the  key:

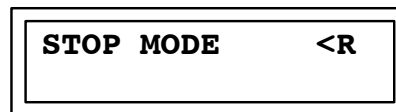

Each time the —/+ key is pressed, the mode is toggled. When the desired operating mode is displayed on the screen, the change is initiated by pressing the ENT key.

Press the  key:



Note that the PLC State field now indicates "stopped" by <S being displayed.

Enter the Insert Mode of Operation

Press the  key:

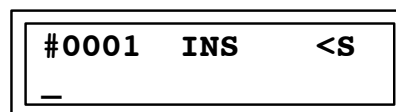

"_" Blinking

You are now ready to enter an element into Step 1 (#0001 on the screen). This is the beginning of the program and the beginning of a rung of logic, therefore the contact must be a normally open or normally closed series contact.

Enter a normally open contact that is attached to the left power bus and reference this contact to input number 1 (I0001). The ladder logic will look like the following:



The statement list for the above ladder logic is:

0001: LD I0001

Initial display:

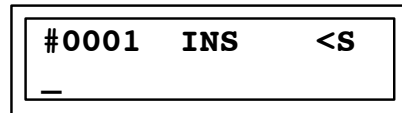

Press the  key:

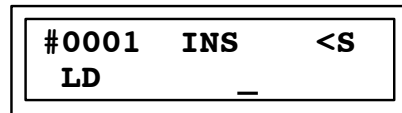

Press the key sequence   :

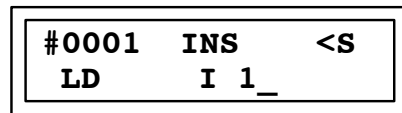

At this point if an error was made or a wrong key was pressed, press the CLR key as many times as needed to clear the ERROR and re-enter the data or start over. See chapter 5, Program Edit for more details.

Pressing the Enter key at this point will place the programmed element into the CPU memory. The display will then advance to the next step.

Press the  key:

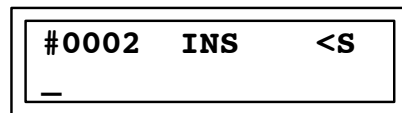

Important- Please Read the Following

To enter program steps using the Hand-Held Programmer, the CPU *must* be in the STOP mode and the Hand-Held Programmer *must* be in the PROGRAM and INSERT modes. After you press the INS key, the initial display will be:

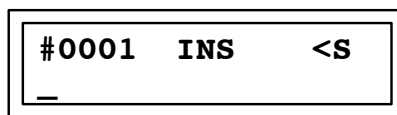

You can now begin entering program steps.

SINGLE CONTACT, SINGLE COIL

To implement the following logic using LD, NOT, and OUT.

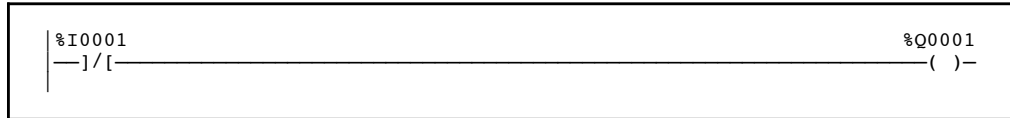

Statement List

```
#0001: LD NOT %I0001
#0002: OUT %Q0001
```

Key Strokes

HHP Display

Initial display:

```
#0001  INS  <S
_
```

Press the key sequence

LD
F NOT
A I / AI
1 :

```
#0001  INS  <S
LD NOT I 1_
```

Press the ENT key:

```
#0002  INS  <S
_
```

Press the key sequence

OUT / OUTM
B Q / AQ
1 :

```
#0002  INS  <S
OUT      Q 1_
```

Press the ENT key:

```
#0003  INS  <S
_
```

SERIES CONTACTS, SINGLE COIL

To implement the following logic using the AND element.

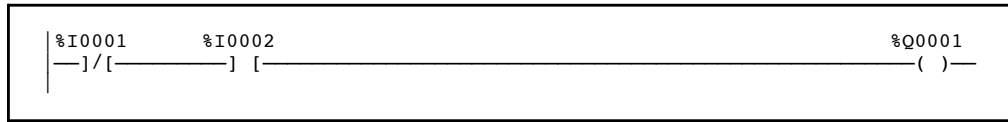

Statement List

#0001: LD NOT %I0001
 #0002: AND %I0002
 #0003: OUT %Q0001

Key Strokes

HHP Display

Initial display:

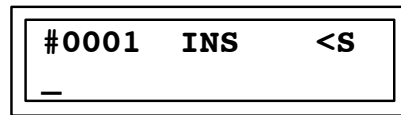

Press the key sequence

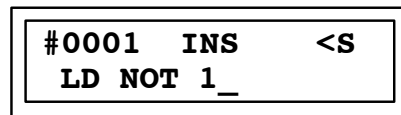
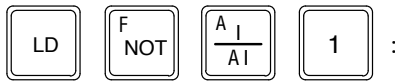

Press the  key:

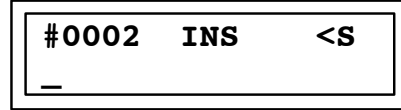

Press the key sequence

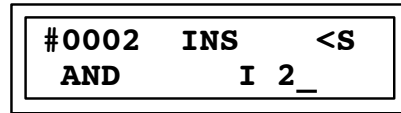
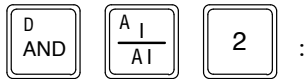

Press the  key:

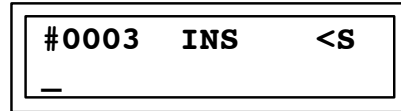

Press the key sequence

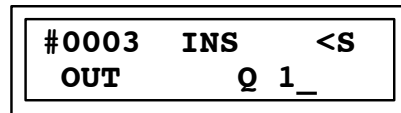
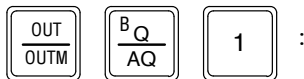

Press the  key:

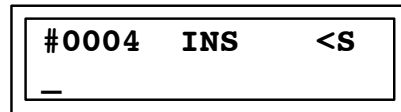

SINGLE PARALLEL CONTACTS, SINGLE COIL

To implement the following logic using the OR element.

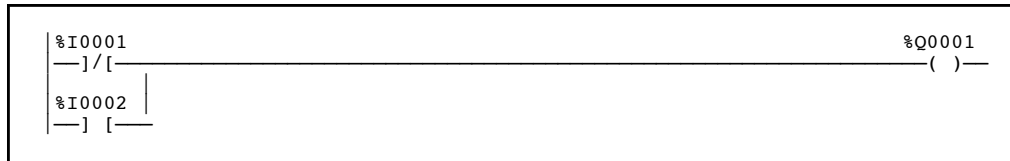

Statement List

```

#0001: LD NOT %I0001
#0002: OR %I0002
#0003: OUT %Q0001
  
```

Key Strokes

HHP Display

Initial display:

```

#0001  INS  <S
_
  
```

Press the key sequence

LD
F NOT
A I / AI
1 :

```

#0001  INS  <S
LD NOT  I 1_
  
```

Press the ENT key:

```

#0002  INS  <S
_
  
```

Press the key sequence

E OR
A I / AI
2 :

```

#0002  INS  <S
OR      I 2_
  
```

Press the ENT key:

```

#0003  INS  <S
_
  
```

Press the key sequence

OUT / OUTM
B Q / AQ
1 :

```

#0003  INS  <S
OUT     Q 1_
  
```

Press the ENT key:

```

#0004  INS  <S
_
  
```

MULTIPLE PARALLEL CONTACTS, SINGLE COIL

To implement the following logic using the OR BLK element.

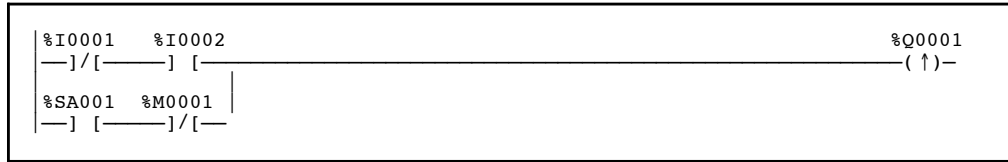

Statement List

```

#0001: LD      NOT    %I0001
#0002: AND
#0003: LD      %I0002
#0004: AND    NOT    %SA001
#0005: OR     BLK
#0006: OUT+   %M0001
#0007: LD      %M0001
#0008: AND    NOT    %I0001
#0009: OUT+   %Q0001
  
```

Key Strokes

HHP Display

Initial display:

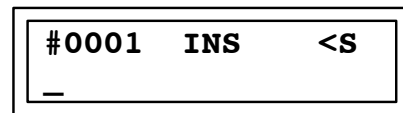

Press the key sequence

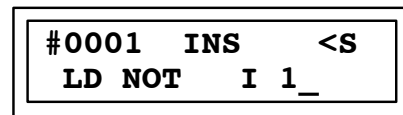
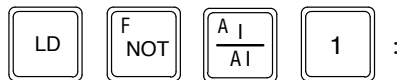

Press the  key:

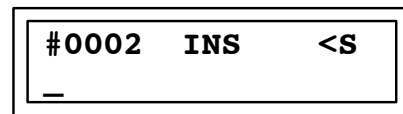

Press the key sequence

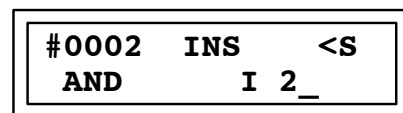
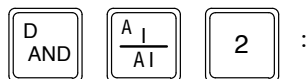

Press the  key:

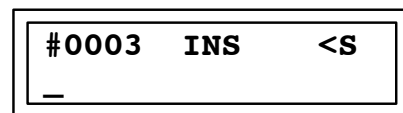

Press the key sequence

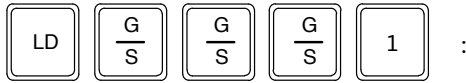

```
#0003  INS  <S
      LD   SA 1_
```

Press the  key:

```
#0004  INS  <S
      _
```

Press the key sequence

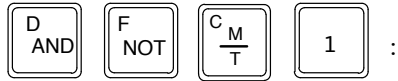

```
#0004  INS  <S
      AND NOT M 1_
```

Press the  key:

```
#0005  INS  <S
      _
```

Press the key sequence   :

```
#0005  INS  <S
      OR BLK _
```

Press the  key:

```
#0006  INS  <S
      _
```

Press the key sequence

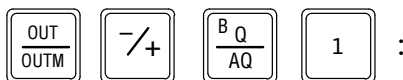

```
#0006  INS  <S
      OUT+   Q 1_
```

Press the  key:

```
#0007  INS  <S
      _
```

SERIES/PARALLEL CONTACTS, SINGLE COIL

To implement the following logic using the AND BLK element.

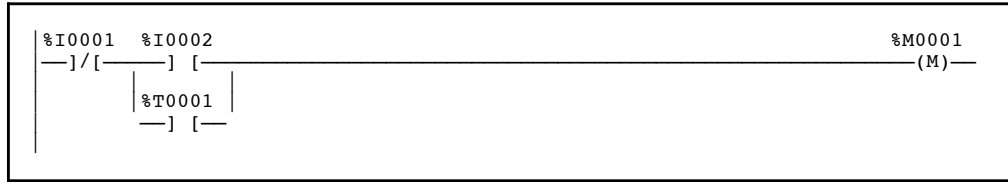

Statement List

#0001:	LD	NOT	%I0001
#0002:	LD		%I0002
#0003:	OR		%T0001
#0004:	AND	BLK	
#0005:	OUTM		%M0001

Key Strokes

HHP Display

Initial display:

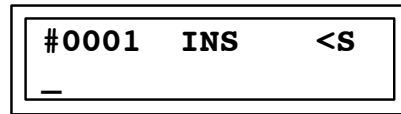

Press the key sequence

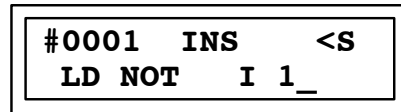
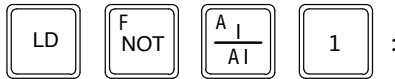

Press the  key:

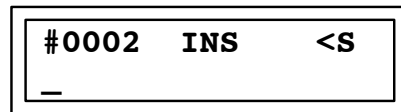

Press the key sequence

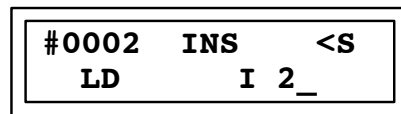
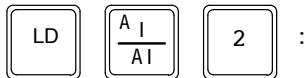

Press the  key:

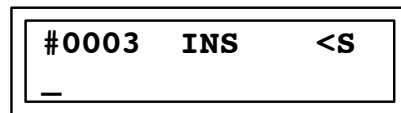

Press the key sequence

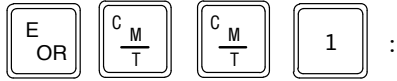

```
#0003  INS  <S
      OR   T  1_
```

Press the  key:

```
#0004  INS  <S
_
```

Press the key sequence   :

```
#0004  INS  <S
      AND BLK
```

Press the  key:

```
#0005  INS  <S
_
```

Press the key sequence

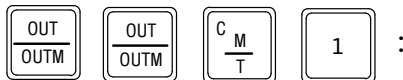

```
#0005  INS  <S
      OUTM  M  1_
```

Press the  key:

```
#0006  INS  <S
_
```

NESTED MULTIPLE COILS ("PILOT LIGHT")

To implement the following logic coils in parallel using the OUT NOT element.

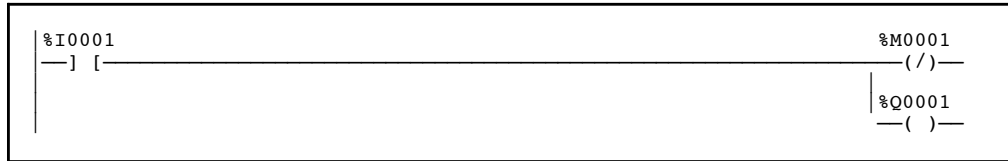

Statement List

```
#0001: LD      %I0001
#0002: OUT    NOT  %M0001
#0003: OUT    %Q0001
```

Key Strokes

HHP Display

Initial display:

```
#0001  INS  <S
_
```

Press the key sequence

LD A I 1 :

```
#0001  INS  <S
LD      I 1_
```

Press the  key:

```
#0002  INS  <S
_
```

Press the key sequence

OUT F C 1 :

OUTM NOT M T

```
#0002  INS  <S
OUT NOT M 1_
```

Press the  key:

```
#0003  INS  <S
_
```

Press the key sequence

OUT B 1 :

OUTM Q AQ

```
#0003  INS  <S
OUT      Q 1_
```

Press the  key:

```
#0004  INS  <S
_
```

NON-NESTED MULTIPLE COILS

To implement the following logic using LD BLK and OUT BLK elements.

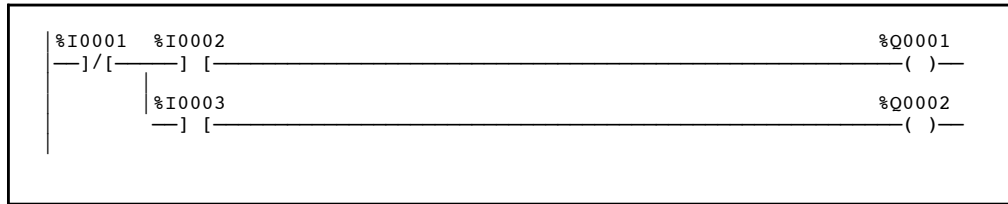

Statement List

#0001:	LD	NOT	%I0001
#0002:	LD	BLK	
#0003:	AND		%I0002
#0004:	OUT		%Q0001
#0005:	OUT	BLK	
#0006:	AND		%I0003
#0007:	OUT		%Q0002

Key Strokes

HHP Display

Initial display:

```
#0001  INS  <S
_
```

Press the key sequence

LD F NOT A I / AI 1 :

```
#0001  INS  <S
LD NOT  I 1_
```

Press the ENT key:

ENT

```
#0002  INS  <S
_
```

Press the key sequence LD BLK :

LD BLK

```
#0005  INS  <S
LD BLK
```

Press the ENT key:

ENT

```
#0003  INS  <S
_
```

Press the key sequence



D AND A I / AI 2 :

```
#0003  INS  <S
AND    I 2_
```

Press the  key:

```
#0004  INS  <S  
_
```

Press the key sequence

   :

```
#0004  INS  <S  
OUT      Q  1_
```

Press the  key:

```
#0005  INS  <S  
_
```



Press the key sequence   :

```
#0005  INS  <S  
OUT BLK
```

Press the  key:

```
#0006  INS  <S  
_
```

Press the key sequence



   :

```
#0006  INS  <S  
AND      I  3_
```

Press the  key:

```
#0007  INS  <S  
_
```

Press the key sequence

   :

```
#0007  INS  <S  
OUT      Q  2_
```

Press the  key:

```
#0008  INS  <S  
_
```

ONE SHOT ON LOSS OF POWER FLOW

To implement the following logic using LD and OUT -.



Statement List

```

#0001: LD      %I0001
#0002: OUT -   %Q0001
  
```

Key Strokes

HHP Display

Initial display:

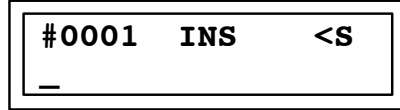

Press the key sequence

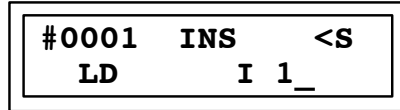
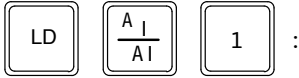

Press the  key:

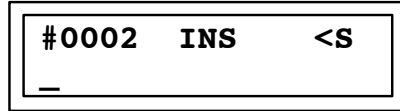

Press the key sequence

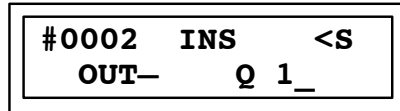
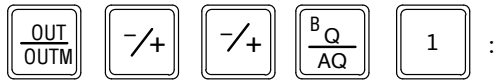

Press the  key:

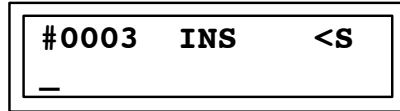

ONE SHOT ON POWER FLOW

To implement the following logic using LD and OUT+.

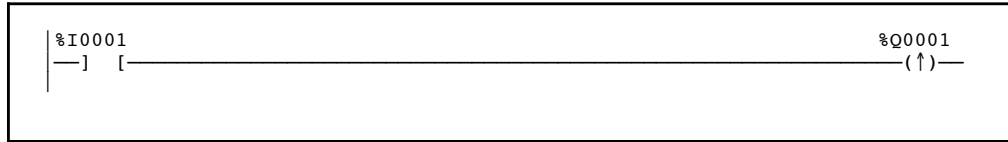

Statement list

#0001: LD %I0001
 #0002: OUT+ %Q0001

Key Strokes

HHP Display

Initial display:

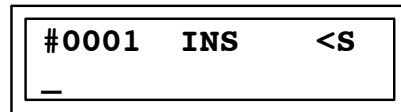

Press the key sequence

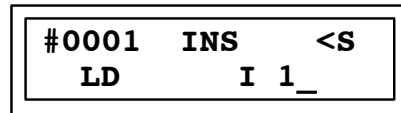
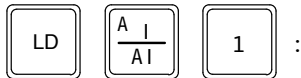

Press the  key:

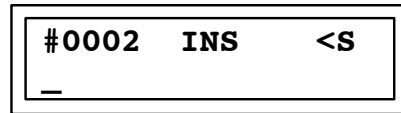

Press the key sequence

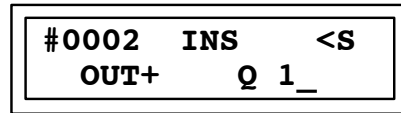

Press the  key:

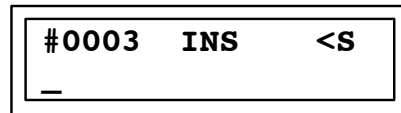

RETENTIVE LATCH

To implement the following logic using SETM.

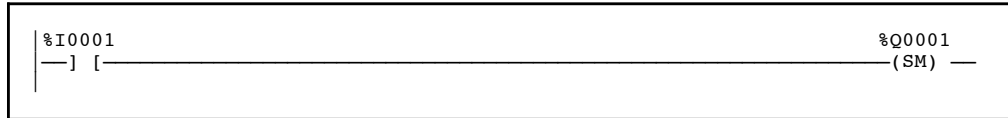

Statement List

```
#0001: LD    %I0001
#0002: SETM  %Q0001
```

Key Strokes

HHP Display

Initial display:

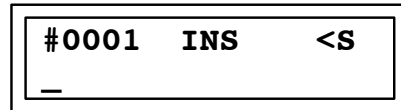

Press the key sequence

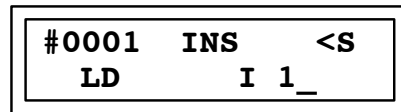
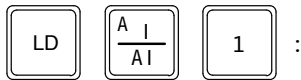

Press the  key:

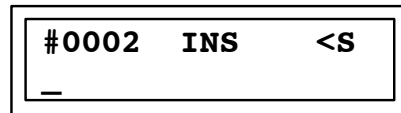

Press the key sequence

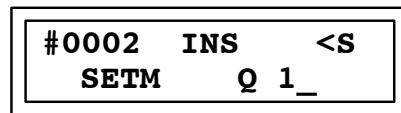
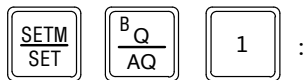

Press the  key:

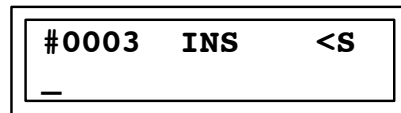

RESETTING A RETENTIVE LATCH

To implement the following logic using RSTM.

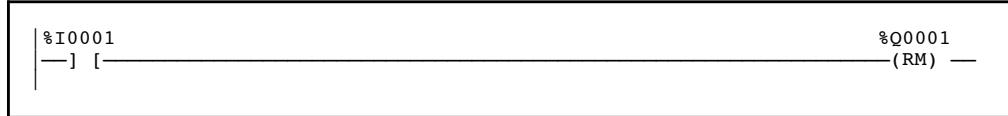

Statement List

```
#0001: LD    %I0001
#0002: RSTM  %Q0001
```

Key Strokes

HHP Display

Initial display:

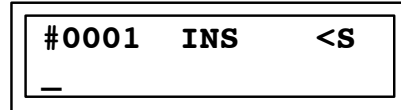

Press the key sequence

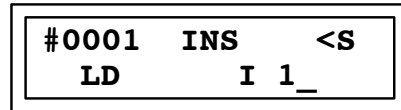
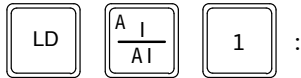

Press the  key:

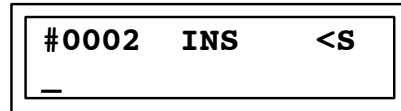

Press the key sequence

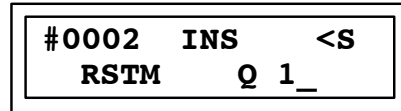
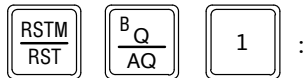

Press the  key:

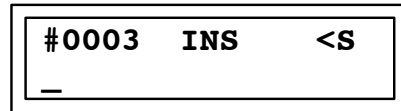

SERIES PARALLEL CONTACTS WITH A LATCH

To implement the following logic using LD, OR NOT, AND NOT, SET

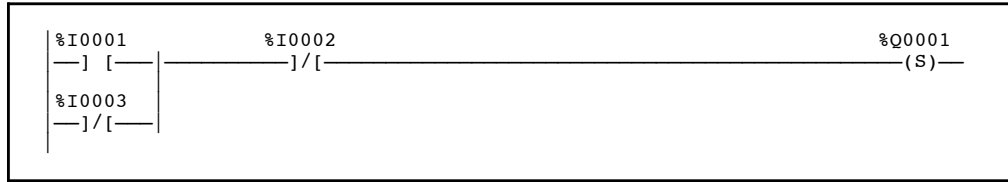

Statement List

```

#0001: LD          %I0001
#0002: OR          NOT %I0003
#0003: AND        NOT %I0002
#0004: SET        %Q0001
  
```

Key Strokes

HHP Display

Initial display:

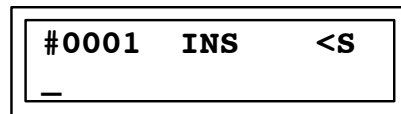

Press the key sequence

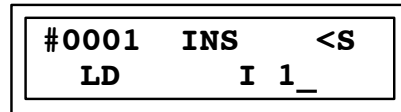
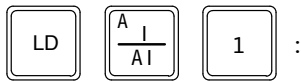

Press the  key:

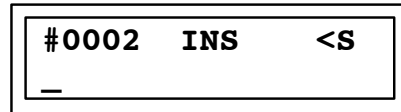

Press the key sequence

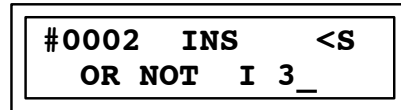
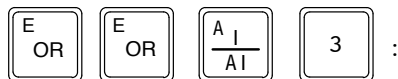

Press the  key:

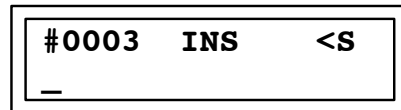

Press the key sequence

D AND	F NOT	A I AI	2
----------	----------	-----------	---

 :

```
#0003  INS  <S  
AND NOT I 2_
```

Press the

ENT J

 key:

```
#0004  INS  <S  
_
```

Press the key sequence

SETM SET	SETM SET	B Q AQ	1
-------------	-------------	-----------	---

 :

```
#0004  INS  <S  
SET      Q 1_
```

Press the

ENT J

 key:

```
#0005  INS  <S  
_
```

Data Types

Data types include the following:

Table 9-3. Data Types

Type	Name	Description	Data Format
INT	Signed Integer	Signed integers use 16-bit memory data locations, and are represented in 2's complement notation. The valid range of an INT data type is —32768 to +32767.	<p>Register 1 S (16 bit positions) 16 1</p>
DINT	Double Precision Signed Integer	Double precision signed integers are stored in 32-bit data memory locations (actually two consecutive 16-bit memory locations) and represented in 2's complement notation. (Bit 32 is the sign bit.) The valid range of a DINT data type is —2147483648 to +2147483647.	<p>Register 2 Register 1 S 32 17 16 1</p> <p>(Two's Complement Value)</p>
BIT	Bit	A Bit data type is the smallest unit of memory. It has two states, 1 or 0. A BIT string may have length N.	
BYTE	Byte	A Byte data type has an 8-bit value. The valid range of a BYTE data type is 0 to 255. A BYTE string may have length N.	
WORD	Word	A Word data type uses 16 consecutive bits of data memory; but, instead of the bits in the data location representing a number, the bits are independent of each other. Each bit represents its own binary state (1 or 0), and the bits are not looked at together to represent an integer number. The valid range of word values is 0 to FFFF.	<p>Register 1 (16 bit positions) 16 1</p>
BCD—4	Four-Digit Binary Coded Decimal	Four-digit BCD numbers use 16-bit data memory locations. Each BCD digit uses four bits and can represent numbers between 0 and 9. This BCD coding of the 16 bits has a legal value range of 0 to 9999.	<p>Register 1 4 3 2 1 (4 BCD digits) 16 13 9 5 1</p>

S = Sign bit (0 = positive, 1 = negative).

Standard Functions and Function Blocks

The standard functions and function blocks of the Statement List programming language are listed in the following table. The abbreviation (mnemonic), function number, function name, and description of each is included. All functions are conditionally executed, except for the LABEL, END MCR, NOOP, and ENDSW functions, .

Table 9-4. Statement List Language Standard Functions and Function Blocks

<i>Abbreviation FunctionNo.</i>		<i>FunctionName</i>	<i>Description</i>	<i>Page 9-xx</i>
<i>Timers and Counters</i>				
TMR	10	Stopwatch timer	Provides simple "stopwatch" timing.	39
ONDTR	13	On-delay timer	Provides on-delay timing.	43
OFDTR	14	Off-delay timer	Provides off-delay timing	48
UPCTR	15	Up counter	Provides incremental counting.	53
DNCTR	16	Down counter	Provides decremental counting.	57
<i>Arithmetic Functions</i>				
ADD	60	Signed addition	Add one signed word or double word value to another.	62
DPADD	61	Double precision signed addition		62
SUB	62	Signed subtraction	Subtract one signed word or double word value from another.	67
DPSUB	63	Double precision signed subtraction		67
MUL	64	Signed multiplication	Multiply one signed word or double word value by another.	72
DPMUL	65	Double precision signed multiplication		72
DIV	66	Signed division	Divide one signed word or double word value by another.	77
DPDIV	67	Double precision signed division		77
MOD	68	Signed modulo division	Modulo divide one signed word or double word value by another.	82
DPMOD	69	Double precision signed modulo division		82
SQRT	70	Signed square root	Find square root of one signed word or double word value.	86
DPSQRT	71	Double precision signed square root		86
<i>Relational Functions</i>				
EQ	52	Equal test	Test for one signed word or double word value equal to another.	91
DPEQ	72	Double precision equal test		91
NE	53	Not equal test	Test for one signed word or double word value not equal to another.	95
DPNE	73	Double precision not equal test		95
GT	57	Greater than test	Test for one signed word or double word value greater than another.	99
DPGT	77	Double precision greater than test		99
GE	55	Greater than or equal test	Test for one signed word or double word value greater than or equal to another.	103
DPGE	75	Double precision greater than or equal test		103
LT	56	Less than test	Test for one signed word or double word value less than another.	107
DPLT	76	Double precision less than test		107
LE	54	Less than or equal test	Test for one signed word or double word value less than or equal to another.	111
DPLE	74	Double precision less than or equal test		111
RANGI	140	Integer range	Test for a signed integer, double precision signed integer, or word value to be within a specified range	115
RANGDI	141	Double precision signed integer range		115
RANGW	142	Word range		115

Table 9-4. Statement List Language Standard Functions and Function Blocks - Continued

<i>Abbreviation FunctionNo.</i>	<i>FunctionName</i>	<i>Description</i>	<i>Page 9-xx</i>
<i>OperationFunctions</i>			
AND	23	Bitwise "and"	Bitwise "and" two words. 122
OR	25	Bitwise "or"	Bitwise "or" two words. 126
XOR	27	Bitwise "exclusive or"	Bitwise "exclusive or" two words. 130
NOT	29	Bitwise one's complement	Bitwise negate (one's complements) a word. 134
SHL	30	Bit shift left	Shift all bits in a word array left a given number of bit positions. 137
SHR	31	Bit shift right	Shift all bits in a word array right a given number of bit positions. 143
ROL	32	Bit rotate left	Rotate all bits in a word array left a given number of bit positions. 149
ROR	33	Bit rotate right	Rotate all bits in a word array right a given number of bit positions. 155
BITSET	22	Bit set	Set a particular bit in a string to a 1. 161
BITCLR	24	Bit clear	Set a particular bit in a string of bits to 0. 165
BITTST	26	Bit test	Determine if a certain bit in a string of bits is set to 1 or 0. 169
BITPOS	28	Bit position	Determines which bit in a string of bits is set to 1. 172
MSKCMPW	143	Masked Compare Word	Compare contents of two bit strings (16-bit words) with ability to mask selected bits. 176
MSKCMPD	144	Masked Compare Dword	Compare contents of two bit strings (32-bit words) with ability to mask selected bits. 176
<i>Data Move Functions</i>			
The default display format of the following Data Move functions is signed integer. They are functionally equivalent to the Data Move functions listed below.			
MOVIN	37	Multiple (array) integer move	Copy an array of multiple words from one location to another. 184
BMOVI	38	Constant block move	Fill seven consecutive words with a block of seven constants. 192
MOVBN	40	Multiple bit move	Move one or more bits from one reference to another. 188
SHFRB	46	Shift register bit	Implement a shift register with bit resolution 208
The default display format of the following Data Move functions is hexadecimal. They are functionally equivalent to the Data Move functions listed above.			
MOVWN	42	Multiple (array) word move	Copy an array of multiple words from one location to another. 184
BMOVW	43	Constant block move	Fill seven consecutive words with a block of seven constants. 192
BLKCL	44	Block clear.	Fills a word or group of consecutive words with zeros. 198
SHFRW	45	N stage word shift register	Perform a word shift through an array of words. 201
SEQB	47	N stage bit sequencer	Perform a bit sequence shift through an array of bits. 212
COMMREQ	88	Communications request	Communicate a particular request to a module in the system. 220
<i>ConversionFunctions</i>			
BCD	80	Integer to BCD conversion	Convert an integer value to a 4-digit BCD value. 225
INT	81	BCD to integer conversion	Convert a 4-digit BCD value to an integer value. 229

Table 9-4. Statement List Language Standard Functions and Function Blocks - Continued

<i>Abbreviation FunctionNo.</i>		<i>FunctionName</i>	<i>Description</i>	<i>Page 9-xx</i>
<i>Control Functions</i>				
DOI/O	85	DoI/Oupdate	Perform an immediate update of a designated range of discrete or analog inputs or outputs.	234
PIDISA	86	PID(proportional/integral/derivative control algorithm)ISA	Implements a standard PID ISA algorithm.	254
PIDIND	87	PID(proportional/integral/derivative control algorithm)IND	Implements an independent term PID IND algorithm.	254
SVCRQ	89	System servicerequest	Request one of the PLC's special services.	251
CALLSUB	90	Callsubroutine	Request a particular subroutine.	266
ENDSW	0	Terminate program logic execution	An unconditionally executed function that acts as a (temporary) program logic execution stream terminator. Normally used during system debug.	241
NOOP	1	No operation	An unconditionally executed function used in support of Logicmaster 90-30/20/Microsoft software package. It supports rung comments functionality.	241
JUMP	3	Nested jump	Control the execution path through the user's logic program. The jump range extends to the previous/next matching LABEL function encountered.	242
MCR	4	Nested master control relay	Used as a master control relay. MCR range extends to the next END MCD function encountered.	246
ENDMCR	8	Master control sequence end	An unconditionally executed function which terminates a control range. END MCR defines the end of a control range for a prior MCR with matching label number.	246
LABEL	7	Target number for jump function.	Provides a destination for a nested JUMP function with a matching label number.	250
<i>Table Functions</i>				
SREQB	101	Search equal to (Byte)	Search for all array values equal to a specified byte value.	270
SREQW	102	Search equal to (Word)	Search for all array values equal to a specified word value.	270
SREQI	103	Search equal to (INT) †	Search for all array values equal to a specified integer value.	270
SREQDI	104	Search equal to (DINT) †	Search for all array values equal to a specified double precision integer value.	270
SRNEB	105	Search not equal to (Byte)	Search for all array values not equal to a specified byte value.	272
SRNEW	106	Search not equal to (Word)	Search for all array values not equal to a specified word value.	272
SRNEI	107	Search not equal to (INT)	Search for all array values not equal to a specified integer value.	272
SRNEDI	108	Search not equal to (DINT)	Search for all array values not equal to a specified double precision integer value.	272

† INT = Integer; DINT = Double precision integer

Table 9-4. Statement List Language Standard Functions and Function Blocks - Continued

<i>Abbreviation FunctionNo.</i>	<i>FunctionName</i>	<i>Description</i>	<i>Page 9-xx</i>	
<i>Table Functions – Continued</i>				
SRLTB	109	Search less than (Byte)	Search for all array values less than a specified byte value.	274
SRLTW	110	Search less than (Word)	Search for all array values less than a specified word value.	274
SRLTI	111	Search less than (INT)	Search for all array values less than a specified integer value.	274
SRLTDI	112	Search less than (DINT)	Search for all array values less than a specified double precision integer value.	274
SRLEB	113	Search less than or equal to (Byte)	Search for all array values less than or equal to a specified byte value.	276
SRLEW	114	Search less than or equal to (Word)	Search for all array values less than or equal to a specified word value.	276
SRLEI	115	Search less than or equal to (INT)	Search for all array values less than or equal to a specified integer value.	276
SRLEDI	116	Search less than or equal to (DINT)	Search for all array values less than or equal to a specified double precision integer value.	276
SRGTB	117	Search greater than (Byte)	Search for all array values greater than a specified byte value.	278
SRGTW	118	Search greater than (Word)	Search for all array values greater than a specified word value.	278
SRGTI	119	Search greater than (INT)	Search for all array values greater than a specified integer value.	278
SRGTDI	120	Search greater than (DINT)	Search for all array values greater than a specified double precision integer value.	278
SRGEB	121	Search greater than or equal to (Byte)	Search for all array values greater than or equal to a specified byte value.	280
SRGEW	122	Search greater than or equal to (Word)	Search for all array values greater than or equal to a specified word value.	280
SRGEI	123	Search greater than or equal to (INT)	Search for all array values greater than or equal to a specified integer value.	280
SRGEDI	124	Search greater than or equal to (DINT)	Search for all array values greater than or equal to a specified double precision integer value.	280
MOVABI	130	Copy array source to destination (bit)	Copy specified number of bits from a source array to a destination array.	290
MOVABY	131	Copy array source to destination (byte)	Copy specified number of bytes from a source array to a destination array.	290
MOVAW	132	Copy array source to destination (word)	Copy specified number of words from a source array to a destination array.	290
MOVAI	133	Copy array source to destination (INT)	Copy specified number of integer values from a source array to a destination array.	290
MOVADI	134	Copy array source to destination (DINT)	Copy specified number of double precision integer values from a source array to a destination array.	290

Editing Functions and Function Blocks

Functions and function blocks are programmed by first pressing the FUNC key, followed by a one or two-digit function number, with the exception that TMR/ONDTR, UPCTR/DNCTR can also be selected by pressing the applicable key on the HHP. Refer to appendix C for a list of supported functions and function blocks.

All functions and function blocks (except for the CEND, LABEL, ENDMCR, NOOP and END functions) have at least one Boolean input; several have more than one Boolean input. The logic controlling a Boolean input must be programmed prior to the actual programming of the function or function block. For those functions and function blocks with more than one Boolean input, the logic for each input must be programmed in top-to-bottom order. Many functions and function blocks have a single Boolean output which either indicates a result of the operation, or merely propagates power flow. In addition, many functions and function blocks have parameters which must be specified as part of programming them. Refer to the following sections in this chapter for information on Boolean inputs, Boolean outputs, and parameters associated with each function and function block.

The functions CEND, LABEL, ENDMCR, NOOP and END are referred to as *single instruction sequences*. These functions have no Boolean inputs or Boolean output. When one of them appears, it is treated as an instruction sequence consisting of only a single instruction.

Many functions and function blocks have parameters where a constant is a valid memory type. You can specify whether a constant should be entered as a decimal or hexadecimal value by pressing the HEX/DEC key. By default, the entry base is always decimal. Pressing the HEX/DEC key toggles between the two bases.

Many functions and function blocks have word-size parameters, where a discrete reference is a valid memory type. The discrete reference address must be on a byte boundary (for example, %I1, %I9, %I17, %I33). If you enter a reference address not on a byte boundary, the software will automatically adjust the reference address downwards to the nearest byte boundary. The message, *REF ADJ*, is displayed to warn you of the adjustment which has been made and the next parameter screen is not displayed as part of this operation.

For example, if you tried to enter %I2 as a reference address, it would be automatically adjusted down to the nearest word boundary, %I1. The current screen would be displayed, showing the adjustment made along with an informative message indicating that the change was made.

```
#0002 REF ADJ <S
P1 I0001_
```

For all double precision functions, the parameters are double-size words; each of these parameters occupies two registers (32-bits), the one specified and the next higher register.

For TMR, ONDTR, UPCTR, and DNCTR function blocks, and the SEQB function, the location parameters are triple-size words. Therefore, the data occupies the register specified plus the two following registers.

For the DOI/O function, if %I or %Q is being snapshot, the start and end parameters must bracket a multiple of eight discrete points. To do this, the start parameter is

restricted to the beginning of a byte boundary (%I, %I9, %I17), and the end parameter is restricted to the end of a byte boundary (%I8, %I16, %I24).

To program an instruction sequence which contains one or more functions or function blocks, follow these guidelines:

1. A function or function block which has one or more Boolean inputs cannot be the first instruction of an instruction sequence.
2. The Boolean output of a function or function block does not have to be connected to any other logic. For example, a function or function block may terminate an instruction sequence.
3. If a Boolean output of a function block is used to control other logic, it may only control the enable input of another function or function block, or control an output coil.
4. No contact instruction may follow a function or function block instruction in an instruction sequence.
5. Functions and function blocks with multiple Boolean inputs cannot appear after another function in an instruction sequence.

As function numbers are entered, the function mnemonic corresponding to the currently entered number is displayed immediately to the right. If no mnemonic is displayed, the current function number is not defined. The +/- key may be used to sequence through function numbers in increasing order only.

For functions and function blocks with multiple Boolean inputs, the logic for each input is programmed in the top-down order in which they appear in the function or function block definition. For the ONDTR function block, this means the enable input logic is programmed first.

A Function Block and its associated parameters are programmed into a single CPU logic memory location called a step. This step contains the function type and each parameter of this function.

The Up and Down cursor keys are used to view the next and previous steps, respectively, of the program, from the current instruction step. Function parameters cannot be viewed with these keys. The Function Type is programmed as the first item in a step then the Left and Right cursor keys are used to view the next and previous parameters, respectively, of a function. They are *only* valid if the current instruction step is a function. New instruction steps may not be viewed with these keys.

Section 1: Timers and Counters

Timers and Counters have operating values as well as programming parameters. One of the operating values is also the same as a programming parameter. The operating values are:

CURRENT VALUE: The current value is the present count or elapsed time since the timer/counter started.

PRESET VALUE: The preset value indicates how many time units (tenth of a second or hundredth of a second) or counts the function should delay from the time the function received power flow to the time it passes power flow through it.

CONTROL WORD: The control word is used to store the state of the enable input, Q output and the timer accuracy.

These values are located in and occupy three sequentially numbered register locations of the register memory. The lowest numbered register of the three is the defining location for this timer or counter.

Table 9-5. Operating Registers and Register Locations

Data Located in the Register	Consecutive Registers
current value (CV)	register 1 *
preset value (PV)	register 2
control word	register 3

* Programmed as the Timer/CounterLocationRegisterAddress

The timer/counter location register (register 1) is the register number that is programmed as parameter P3 (timer location) when programming a timer, and as parameter P2 (counter location) when programming a counter. The data found in this register is the current value of the timer or counter it represents. The preset value can be found in the second of the three consecutive registers, which for a timer is programmed as parameter P2, and for a counter is programmed as parameter P1. The third register of the three consecutive registers has the control word stored in it.

Caution

Do not write to the third register of the three sequential registers which contain Timer and Counter operating values. Changing the data in the control information word may result in unexpected operation of the PLC.

When programming the preset parameter (which is P2 for a timer and P1 for a counter) a special constant value of * 1 (minus 1) may be used. This special constant value of * 1 tells the controller to use the data located in the second register of the three sequential operating registers as the preset value. Thus by programming a * 1 as the preset

parameter you can go to the data mode and call up the second operating register for a specific counter or timer and load data into this register to represent the preset value.

Note

When programming a * 1 as the preset parameter value the preset data is not stored in the program, and is retained only as a value in this operating register.

Stop-Watch Timer (TMR) Function 10

The stop-watch timer (TMR) is a conditionally executed function which provides simple stop-watch timing. When the logic controlling the enable (EN) input passes power flow to this function the current value starts at a value of zero and increments in steps which are equal to the value programmed as the timer accuracy parameter P1. It continues incrementing as long as the function receives power flow at its enable (EN) inputs, even if the current value is greater than the preset value up to a decimal value of 32767. When power flow is removed from the enable input the current value stops incrementing and is reset to zero.

Power flow will pass through this function when the current value is equal to or greater than the preset value (timer parameter P2). If power flow to the enable input is removed power flow through this function is also removed. This Timer is retentive upon power failure. When the CPU mode is changed to the Stop Mode and power flow is maintained at the Enable input, the current value will stop incrementing and maintain its value when returning to the Run Mode. The current value will continue to increment starting from this maintained value.

Timing is done in increments of tenth (.1) of a second or hundredths (.01) of a second; the preset value programmed as parameter P2 is a value that represents a number of these timing increments. For example, assume that tenths of a second is programmed as the timer accuracy for parameter P1 and the number 50 is a constant value programmed as the preset parameter P2. Power flow through this function will take place after 50 tenths of a second increments were recorded into the current value, which is 5 seconds after the enable input receives and maintains power flow. If the timer accuracy was programmed as hundredths of a second and the preset remained at 50, power flow would occur after 50 one hundredths of a second increments were recorded into the current value which is 0.5 seconds or one half second after the enable input received and maintained power flow.

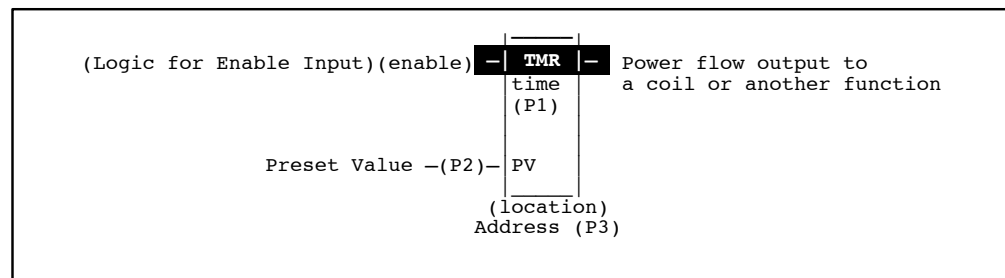

Programming Elements and Sequential Order of Programming

1. Logic controlling the enable input from the left bus. Must start with an LD element.
2. Type of function (Function 10).
3. Parameter P1 (timer accuracy), base value for timing increments;
 - 1 = one hundredth of a second (.01 second),
 - 10 = one tenth of a second (0.1 second).
4. Parameter P2 (preset time), a constant number or the number of a register that will contain the preset value.
5. Parameter P3 (timer location), number of the first register of the three sequential registers containing the operating values.

The following table specifies the valid memory types for each of the TMR function block's parameters:

Allowable Memory Types for TMR (Function 10)

Parameter	%I	%Q	%M	%T	%G	%S	%R	%AI	%AQ	Constant
Timer Accuracy(P01)										• †
Preset Time(P02)	•	•	•	•	•		•	•	•	• ‡
Timer Location(P03)							•			

† Only constants of 1, 10, and 100 are allowed.

‡ Only positive constants are allowed, except * 1 which indicates no preset parameter.

Timer Accuracy (P01): The timer accuracy parameter indicates the time base of the timer. A constant of 1 indicates a time base of 0.01 seconds; 10 indicates a time base of 0.1 seconds; and 100 indicates a time base of .001 seconds.

Preset Time (P02): The preset time parameter indicates the time period for the stop-watch timer. If specified, it is indicated by a positive (only) 16-bit two's complement signed integer (0 ... 32,767). The constant * 1 indicates that no preset time parameter is specified. For this case, the preset time will be accessed from the timer data structure. (Operating Register)

Timer Location (P03): The timer location gives the address of a three-word data structure which is used by the timer function block.

Programming Example for TMR Function

In the following example, power flow will be passed through the Timer to turn on %Q0001 at a time of 2.5 seconds after input 1 is closed or input 2 is opened. The Time Base or Timer Accuracy is a tenth of a second (.01); the Preset is a constant of 25, and Location of this Timer is Register 1.

Ladder Diagram Representation

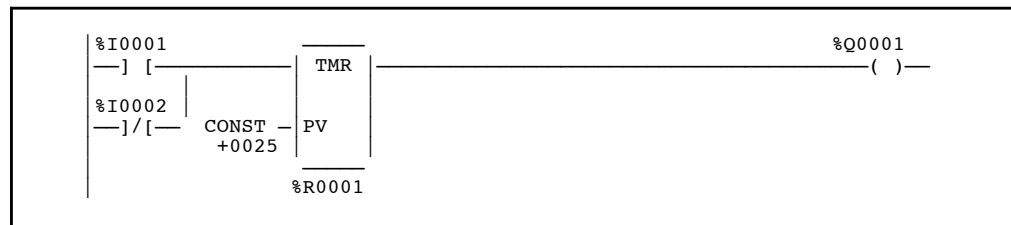

Statement List Representation

```

#0001:      LD          %I0001
#0002:      OR          NOT %I0002
#0003:      FUNC        10      TMR
            P1:         10
            P2:         25
            P3:         %R0001
#0004:      OUT          %Q0001
    
```

After pressing  Key: Programming sequence



Key Strokes

HHP Display

Initial display:

```
#0001  INS  <S  
_
```

Press the key sequence





   :

```
#0001  INS  <S  
LD      I 1_
```

Press the  key:

```
#0002  INS  <S  
_
```

Press the key sequence





    :

```
#0002  INS  <S  
OR NOT  I 2_
```

Press the  key:

```
#0003  INS  <S  
_
```

Press the key sequence

   or  :

```
#0003  INS  <S  
FUNC 10  TMR
```

Press the  key:

```
#0003  TMR  <S  
P01
```

Press the key sequence 1 0 :

```
#0003 TMR <S
P 10
```

Press the ENT
↓ key:

```
#0003 TMR <S
P02
```

Press the key sequence 2 5 :

```
#0003 TMR <S
P02 25_
```

Press the ENT
↓ key:

```
#0003 TMR <S
P03
```

Press the key sequence R 1 :

```
#0003 TMR <S
P03 R 1_
```

Press the ENT
↓ key:

```
#0004 INS <S
_
```

Press the key sequence OUT
OUTM B Q
AQ 1 :

```
#0004 INS <S
OUT Q 1_
```

On Delay (ONDTR) Function 13

The on-delay timer (ONDTR) is a conditionally executed function which provides on-delay timing. When the logic controlling the enable (EN) input passes power flow to this function the current value starts at a value of zero and increments as long as the function receives power flow at its enable (EN) input even if the current value is greater than the preset value up to a decimal value of 32767. The timing increments may be in tenths of a second or hundredths or a second. When power flow is removed from the enable input the current value stops incrementing and maintains its current value. When power flow is restored to this functions enable input, the current value will continue to increment starting from this maintained value.

Power flow will pass through this function when the current value of timing increments is equal to or greater than the specified number of timing increments programmed in as the preset value (timer parameter P2).

When the logic connected to the reset (R) input passes power to this function the current value is reset to zero and the power flow through this function is also removed. Power flow to the reset input is dominant over the enable input. That is, if power flow is received at both the enable input and the reset input at the same time; the current value will be set to a value of zero, it will not increment in value, and there will be no power flow through the function.

The On Delay timer is retentive on power failure to the CPU, and when the mode is changed from run to stop and back to run again. There is no automatic initialization of this timer during power up, i.e. the current value does not go to zero unless this timer is reset.

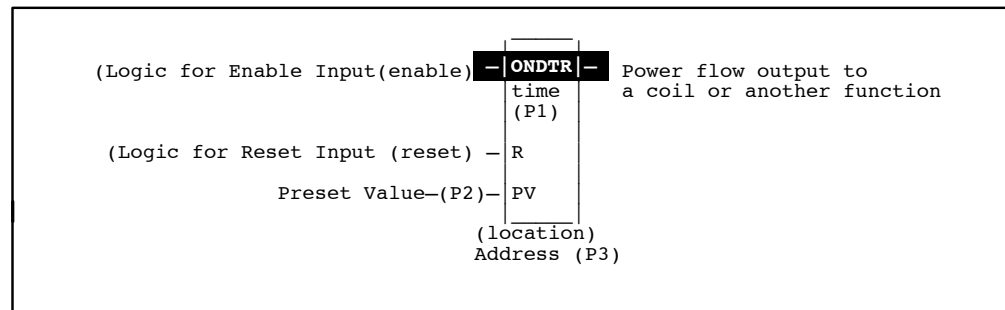

Programming Elements and Sequential Order of Programming

1. Logic controlling the enable input from the left bus. Must start with an LD element.
2. Logic controlling the reset input from the left bus. This logic must start with an LD element.
3. Type of function (Function 13).
4. Parameter (P1) Timer Accuracy or base value for timing increments;
 - 1 = one hundredth of a second (.01 second),
 - 10 = one tenth of a second (0.1 second).
5. Parameter (P2) Preset Time, a constant number or the number of a register that will contain the preset value.
6. Parameter (P3) Timer Location, number of the first register of the three sequential registers containing the operating values.

The following table specifies the valid memory types for each of the ONDTR function block's parameters:

Allowable Memory Types for ONDTR (Function 13)

Parameter	%I	%Q	%M	%T	%G	%S	%R	%AI	%AQ	Constant
Timer Accuracy(P01)										•†
Preset Time (P02)	•	•	•	•	•		•	•	•	•‡
Timer Location(P03)							•			

† Only constants of 1, 10, and 100 are allowed.

‡ Only positive constants are allowed, except —1 which indicates no preset parameter.

Timer Accuracy (P01): The timer accuracy parameter indicates the time base of the timer. A constant of 1 indicates a time base of 0.01 seconds; 10 indicates time base of 0.1 seconds; and 100 indicates a time base of .001 seconds.

Preset Time (P02): The preset time parameter indicates the time period for the on-delay timer. It is indicated by a positive (only) 16-bit two's complement signed integer (0 ... 32,767). The constant * 1 indicates that no preset time parameter is specified. For this case, the preset time will be accessed from the timer data structure (Operating Registers).

Timer Location (P03): The timer location gives the address of a three-word data structure which is used by the timer function block.

Programming Example for ONDTR Function

In the following example power flow will be passed through the Timer to turn on %Q0002 after a specified time delay from the time input number 1 closes or internal contact 2 is turned on. The time delay will be the number of tenths of a second specified by the decimal number stored in Register 90. A not contact of coil %Q0001 is programmed to the reset input, thus when coil %Q0001 is off (current flow will occur through the reset logic). The current value will not increment and is set to zero.

The Time Base or Accuracy P1 is a tenth of a second (0.1).

The Preset P2 is a number stored in register 90.

The Location Register P3 is Register 4.

Ladder Diagram Representation

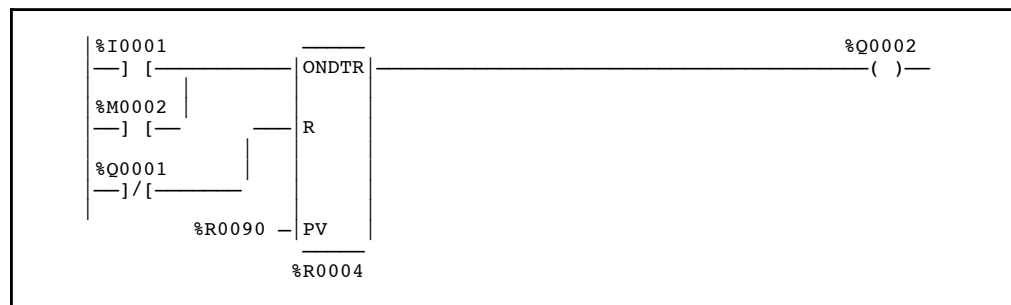

Statement List Representation

#0001: LD		%I0001
#0002: OR		%M0002
#0003: LD	NOT	%Q0001
#0004: FUNC	13	ONDTR
	P1:	10
	P2:	%R0090
	P3:	%R0004
#0005: OUT		%Q0002

After pressing  Key: Programming sequence



Key Strokes

HHP Display

Initial display:

#0001	INS	<S
—		

Press the key sequence



 :

#0001	INS	<S
LD	I 1	—

Press the  key:

#0002	INS	<S
—		

Press the key sequence



 :

#0002	INS	<S
OR	M 2	—

Press the  key:

#0003	INS	<S
—		

Next, the logic for the reset input is programmed.

Press the key sequence

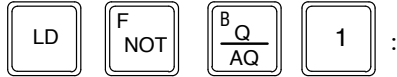

```
#0003  INS  <S  
LD NOT  Q 1_
```

Press the  key:

```
#0004  INS  <S  
_
```

Press the key sequence

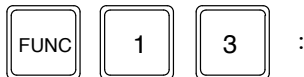

```
#0004  INS  <S  
FUNC 13_ ONDTR
```

Press the  key:

```
#0004  ONDTR <S  
P1 _
```

Press the key sequence   :

```
#0004  ONDTR <S  
P1 10_
```

Press the  key:

```
#0004  ONDTR <S  
P2 _
```

Press the key sequence



```
#0004  ONDTR <S  
P2 R 90_
```

Press the  key:



```
#0003  ONDTR <S  
P3 _
```

Press the key sequence   :

```
#0004  ONDTR  <S  
P3    R 4_
```

Press the  key:

```
#0005  INS    <S  
_
```

Press the key sequence    :

```
#0005  INS    <S  
OUT           Q 2_
```

Press the  key:

```
#0006  INS    <S  
_
```

Off Delay (OFDTR) Function 14

The off-delay timer (OFDTR) increments while power flow is off, and resets to zero, when power flow is on. Time may be counted in tenths of seconds (the default selection), or hundredths of seconds. The range is 0 to +32767 time units. The state of this timer is retentive on power failure; no automatic initialization occurs at power-up.

When the OFDTR first receives power flow, it passes power to the right and clears the current value (CV) located in the operating registers of the timer. The output remains on as long as the function receives power flow. If the function stops receiving power flow from the left, it continues to pass power to the right and the timer starts accumulating time in CV. Each time the function is invoked with the enabling logic set OFF, the current value is updated to reflect the time since the timer was turned off. When the current value (CV) is equal to or greater than the preset value (PV), the function stops passing power flow to the right.

When the function receives power flow again, the current value resets to zero and the output is enabled again.

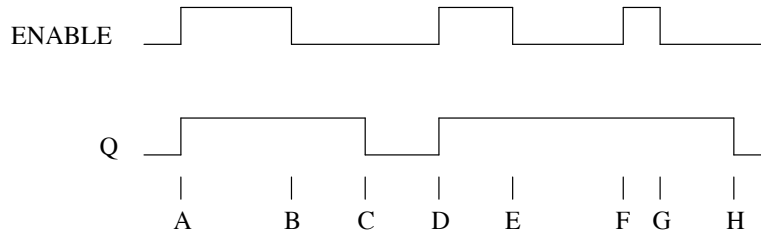

- A = ENABLE and Q both go high; timer is reset (CV = 0).
- B = ENABLE goes low; timer starts accumulating time.
- C = CV reaches PV; Q goes low, and timer stops accumulating time.
- D = ENABLE goes high; timer is reset (CV = 0).
- E = ENABLE goes low; timer starts accumulating time.
- F = ENABLE goes high; timer is reset (CV=0).
- G = ENABLE goes low; timer begins accumulating time.
- H = CV reaches PV; Q goes low, and timer stops accumulating time.

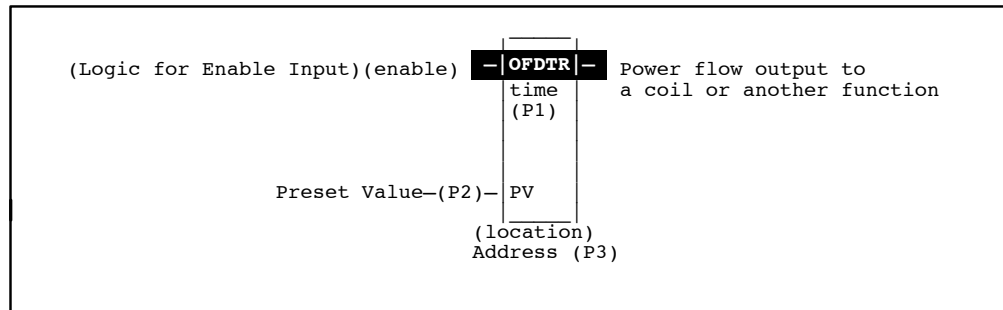

Programming Elements and Sequential Order of Programming

1. Logic controlling the enable input from the left bus. Must start with an LD element.
2. Type of function (Function 14)
3. Parameter (P1) Timer Accuracy or base value for timing increments;
 1 = one hundredth of a second (.01 second),
 10 = one tenth of a second (0.1 second).
4. Parameter (P2) Preset Time, a constant number or the register that will contain the preset value.
5. Parameter (P3) Timer Location, the first register of the three sequential registers containing the operating values.

Parameters for OFDTR (Function 14)

The following table specifies the valid memory types for each of the OFDTR function block's parameters:

Allowable Memory Types for OFDTR (Function 14)

Parameter	%I	%Q	%M	%T	%G	%S	%R	%A I	%A Q	Constant
Timer Accuracy(P01)										•†
Preset Time (P02)	•	•	•	•	•		•	•	•	•‡
Timer Location (P03)							•			

† Only constants of 1, 10, and 100 are allowed.

‡ Only positive constants are allowed, except —1 which indicates no preset parameter.

Timer Accuracy (P1): The timer accuracy parameter indicates the time base of the timer. A constant of 1 indicates a time base of 0.01 second; 10 indicates a time base of 0.1 seconds; and 100 indicates a time base of .001 seconds.. Other values are not accepted as a valid parameter value.

Preset Time (P2): The preset time parameter indicates the time period for the off-delay timer. It is indicated by a positive (only) 16-bit twos complement signed integer (0...32,767). A constant of -1 indicates that no preset time parameter is specified. In this case, the preset time will be accessed from the timer's Operating Registers.

Timer Location (P3): The timer location gives the address of a three-word data structure used by the timer function block.

Programming Example for OFDTR Function

In the following example, power flow will be passed through the OFDTR to turn on %Q0001 when %I0001 is enabled. After 2.5 seconds %Q0001 goes from being closed to opened. The Time Base or Timer Accuracy is a tenth of a second (.1); the Preset is a constant of 25, and the Location of this OFDTR is Register 1.

Ladder Diagram Representation

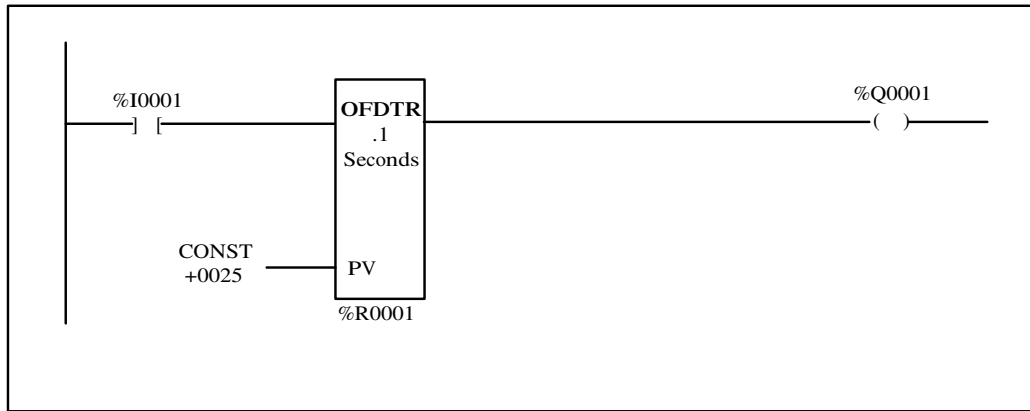

Statement List Representation

```
#0001: LD          %I0001
#0002: FUNC      14   OFDTR
           P1:    10
           P2:    25
           P3:    %R0001
#0003: OUT          %Q0001
```

After pressing INS Key: Programming sequence

Key Strokes

HHP Display

Initial display:

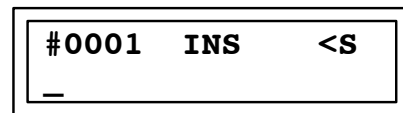

Press the key sequence

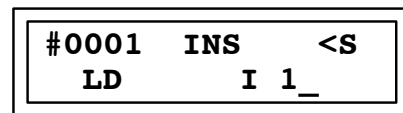
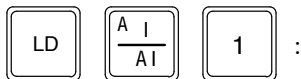

Press the  key:

```
#0002  INS  <S  
_
```

Press the key sequence

   :

```
#0002  INS  <S  
FUNC 14_ OFDTR
```

Or press the  key 3 times

Press the  key:



```
#0002  OFDTR <S  
P01 _
```

Press the key sequence   :

```
#0002  OFDTR <S  
P1  10_
```

Press the  key:

```
#0002  OFDTR <S  
P02 _
```

Press the key sequence   :

```
#0002  OFDTR <S  
P02  25_
```

Press the  key:



```
#0002  OFDTR <S  
P03 _
```

Press the key sequence   :

```
#0002 OFDTR <S  
P03 R 1_
```

Press the  key:

```
#0003 INS <S  
_
```

Press the key sequence    :

```
#0003 INS <S  
OUT Q 1_
```

Press the  key:

```
#0004 INS <S  
_
```

Up Counter (UPCTR) Function 15

The up counter (UPCTR) is a conditionally executed function which provides incremental counting. Each time the logic controlling the count input goes from a condition of no power flow to a condition of power flow to this function the current value will be incremented by a value of one. The current value will increment until the decimal number 32767 is reached. This up counter will pass power flow when the current value is equal to or greater than the the number programmed as the preset value.

When the logic controlling the reset (R) input passes power flow to the reset input the current value will be reset to zero and the power flow through this function will be removed. Power flow to the reset input is dominant over the count input. If power flow is being received at the reset input when the count input goes from a condition of no power flow to a condition of power flow the current value will stay at a value of zero and will not increment. These power flow conditions are shown in the following table (this table is applicable to both the Up Counter and Down Counter functions).

PowerFlow Condition at Reset Input	Power Flow at Counter Input		Counter Execution	Power Flow Through This Counter	
	Previous Condition	Current Execution		CV < PV	CV w PV
No	No	No	CV does not increment	No	Yes*
No	No	Yes	CV increments by 1	No	Yes
No	Yes	No	CV does not increment	No	Yes
No	Yes	Yes	CV does not increment	No	Yes
Yes	No	No	CV resets to zero	Off	Off
Yes	No	Yes	CV resets to zero	Off	Off
Yes	Yes	No	CV resets to zero	Off	Off
Yes	Yes	Yes	CV resets to zero	Off	Off

CV=current value, PV=preset value, Yes=power flow, No=no power flow, <=less than, w =greater than or equal to
 * When there is no power flow to the enable input and the preset value is changed to less than the current count, power flow will pass through this function.

The up counter is retentive on power failure to the CPU, and when the mode is changed from run to stop and back to run again. There is no automatic initialization during power up; the current value does not go to zero unless this up counter is reset.

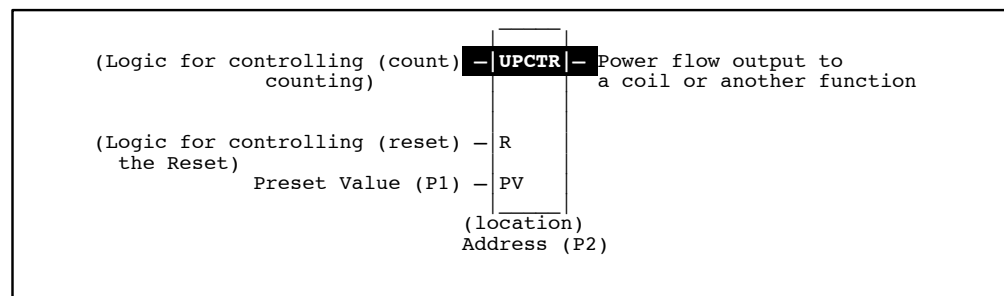

Programming Elements and Sequential Order of Programming

1. Logic controlling the count input from the left bus. Must start with an LD element.
2. Logic controlling the reset input from the left bus. This logic must start with an LD element.
3. Type of function (Function 15).
4. Parameter P1 (preset value). This can be a constant number or the number of a register that will contain the preset value.
5. Parameter P2 (counter location), number of the first register of the three sequential registers containing the operating values.

The following table specifies which memory types are valid for each of the UPCTR function block's parameters:

Allowable Memory Types for UPCTR (Function 15)

Parameter	%I	%Q	%M	%T	%G	%S	%R	%AI	%AQ	Constant
Preset Value(P01)	•	•	•	•	•		•	•	•	•†
Counter Location(P02)							•			

† Only positive constants are allowed, except * 1 which indicates no preset parameter.

Preset Value (P01): The preset value parameter indicates the count range for the up counter. If specified, it is indicated by a positive (only) 16-bit two's complement signed integer (0 ... 32,767). The constant * 1 indicates that no preset count parameter is specified. For this case, the preset count will be accessed from the counter data structure (Operating Register).

Counter Location (P02): The counter location gives the address of a three-word data structure which is used by the counter function block.

Programming Example for UPCTR Function

In the following example power flow will be passed through the Counter Function to turn on %Q0001 after the input %I0001 goes from an open state to a closed state 8 times (for a count of 8). Each time input 1 goes from open line (no power flow) to closed (power flow) the current value will increment by one. When input %I0002 closes (gives power flow), the reset line is activated setting the current count to zero and preventing power flow through this counter, and %Q0001 is turned OFF. The preset value is a constant 8; the location register is register 10.

Ladder Diagram Representation

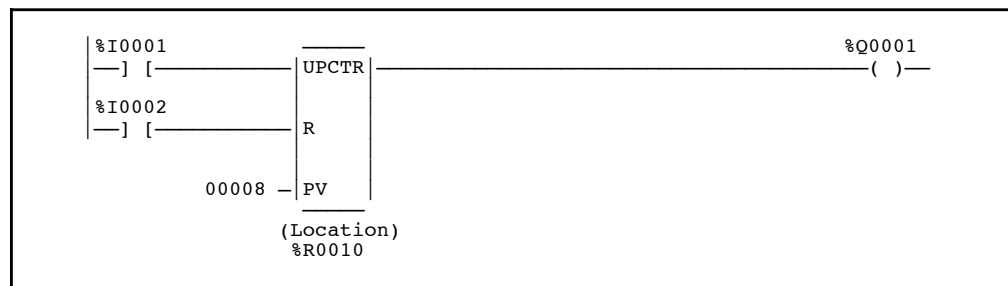

Statement List Representation

#0001: LD		%I0001
#0002: LD		%I0002
#0003: FUNC	15	UPCTR
	P1:	8
	P2:	%R0010
#0004: OUT		%Q0001

After pressing  Key: Programming sequence



Key Strokes

HHP Display

Initial display:

#0001	INS	<S
—		

Press the key sequence





 :

#0001	INS	<S
LD	I 1	—

Press the  key:

#0002	INS	<S
—		

Press the key sequence



 :

#0002	INS	<S
LD	I 2	—

Press the  key:

#0003	INS	<S
—		

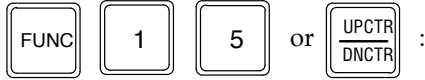
Press the key sequence



```
#0003  INS  <S  
FUNC 15_  UPCTR
```

Press the



key:

```
#0003  UPCTR  <S  
P01_
```

Press the key sequence



:

```
#0003  UPCTR  <S  
P01_  8_
```

Press the



key:

```
#0003  UPCTR  
P02_
```

Press the key sequence



:

```
#0003  UPCTR  <S  
P02 R  10_
```

Press the



key:

```
#0004  INS  <S  
_
```

Press the key sequence

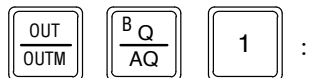

:

```
#0004  INS  <S  
OUT      Q  1_
```

Press the



key:

```
#0005  INS  <S  
_
```

Down Counter (DNCTR) Function 16

The down counter (DNCTR) is a conditionally executed function which provides decremental counting from a preset value. Each time the logic controlling the count input goes from a condition of no power flow to a condition of power flow the current value will be decremented by a value of one. The current value will decrement in value from the preset value until a decimal value of * 32768 is reached. This down counter will pass power flow when the current value is equal to or less than zero.

When the logic controlling the reset (R) input passes power flow to the reset input the current value will be set to the value programmed as the preset value and power flow through the function will be removed. Power flow to the reset input is dominant over the count input. That is if power flow is being received at the reset input when the count input goes from a condition of no power flow to a condition of power flow the current value will stay at the value programmed as the preset value and will not decrement.

The down counter is retentive on power failure to the CPU, and when the mode is changed from run to stop and back to run again. There is no automatic initialization of the down counter during power up, i.e.: the current value does not go to the preset value unless the down counter is reset.

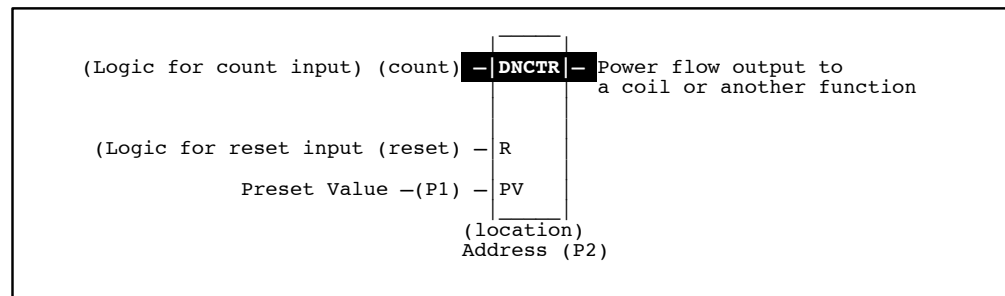

Programming Elements and Sequential Order of Programming

1. Logic controlling the count input from the left bus. Must start with an LD element.
2. Logic controlling the reset input from the left bus. This logic must start with an LD element.
3. Type of function (Function 15).
4. Parameter P1 (preset value). This can be a constant number or the number of a register that will contain the preset value.
5. Parameter P2 (counter location), number of the first register of the three sequential registers containing the operating values.

The following table specifies which memory types are valid for each of the DNCTR function block's parameters:

Allowable Memory Types for DNCTR (Function 16)

Parameter	%I	%Q	%M	%T	%G	%S	%R	%AI	%AQ	Constant
Preset Value(P01)	•	•	•	•	•		•	•	•	•†
Counter Location(P02)							•			

† Only positive constants are allowed, except -1 which indicates no preset parameter.

Preset Value (P01): The preset value parameter indicates the count range for the down counter. If specified, it is indicated by a positive (only) 16-bit two's complement signed integer (0 ... 32,767). The constant -1 indicates that no preset count parameter is specified. For this case, the preset count will be accessed from the counter data structure.

Counter Location (P02): The counter location gives the address of a three-word data structure which is used by the counter function block.

Programming Example for DNCTR Function

In the following example each time input %I0001 goes from open (no power flow) to closed (power flow) the current value will decrement by a value of one. When the current value is less then or equal to zero, power flow through this function will take place and output coil %Q0001 will be turned on. In this example the starting number is 8 (the preset value), thus after 8 counts %Q0001 will turn on. When input %I0002 closes power flow is removed (coil %Q0001 will turn off) and the current value will be changed to 8, the preset value.

Ladder Diagram Representation

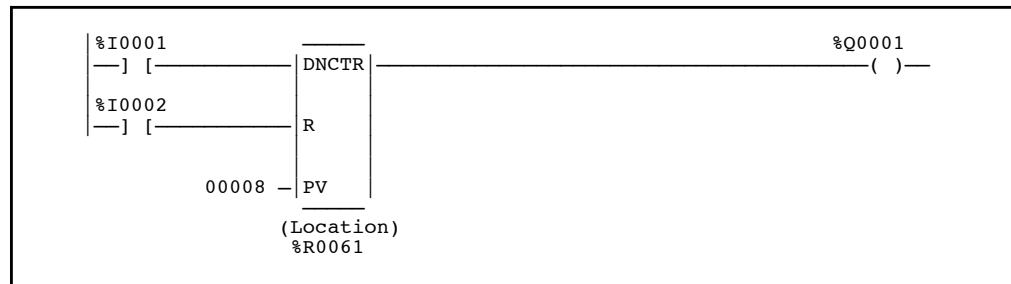

Statement List Representation

```

#0001: LD          %I0001
#0002: LD          %I0002
#0003: FUNC        16  DNCTR
                P1:  8
                P2:  %R0061
#0004: OUT          %Q0001
    
```

After pressing  Key: Programming sequence



Key Strokes

HHP Display

Initial display:

```
#0001  INS  <S  
_
```

Press the key sequence



   :

```
#0001  INS  <S  
LD      I 1_
```

Press the  key:

```
#0002  INS  <S  
_
```

Press the key sequence





   :

```
#0002  INS  <S  
LD      I 2_
```

Press the  key:

```
#0003  INS  <S  
_
```

Press the key sequence

   or   :

```
#0003  INS  <S  
FUNC 16  DNCTR
```

Press the  key:

```
#0003  DNCTR <S  
P01_
```

Press the key sequence 8 :

```
#0003 DNCTR <S
P01_ 8_
```

Press the ENT
↓ key:

```
#0003 DNCTR <S
P02 _
```

Press the key sequence R 6 1 :

```
#0003 DNCTR <S
P02 R 61 _
```

Press the ENT
↓ key:

```
#0004 INS <S
_
```

Press the key sequence OUT
OUTM B Q
AQ 1 :

```
#0004 INS <S
OUT Q 1_
```

Press the ENT
↓ key:

```
#0005 INS <S
_
```

Section 2: Arithmetic Functions

This section describes the arithmetic functions for Series 90-30 and 90-20 PLCs. Arithmetic functions provide both single and double precision addition, subtraction, multiplication and division operators:

Abbreviation	Function	Description
ADD	Addition	Add two numbers.
DPADD	Double PrecisionAddition	Adds two signed double word numbers.
SUB	Subtraction	Subtract one number from another.
DPSUB	Double PrecisionSubtraction	Subtracts one signed double word number from another.
MUL	Multiplication	Multiply two numbers.
DPMUL	Double PrecisionMultiplication	Multiplies one signed double word number by another.
DIV	Division	Divide one number by another, giving only the quotient as a result.
DPDIV	Double PrecisionDivision	Divides one signed double word number by another, giving only the quotient as a result.
MOD	ModuloDivision	Divide one number by another, giving a remainder as a result.
DPMOD	Double PrecisionModuloDivision	Divides one signed double word number by another, giving the remainder as a result.
SQRT	Square Root	Finds the square root of an integer.
DPSQRT	Double PrecisionSquare Root	Finds the square root of a double precision integer.

Note

Division and modulo division are similar functions which differ in their output; division finds a quotient, while modulo division finds a remainder.

Addition (ADD) Function 60

Double Precision Addition (DPADD) Function 61

Two addition functions are available. The signed addition function (ADD) is a conditionally executed function which adds one signed integer value to another, and the double precision signed addition function (DPADD) is a conditionally executed function which adds one signed double word value to another.

When power flow to the enable (EN) input occurs, and the function is executed by the CPU a new signed addition (for ADD) or double precision signed addition (for DPADD) will take place. During a signed addition or double precision signed addition execution the value located in P1 (input 1) is added to the value in P2 (input 2). The result of this addition is stored in the memory location specified by P3 (Q). The ADD and DPADD functions operate on INT (signed integer) and DINT (double precision integer) data respectively. The INT ADD function is Function 60 and the DINT ADD function is function 61.

ADD Function Description

The three values specified by parameters P1, P2, and P3 must be the same data type (16-bit two's complement signed integers) and must be within the range -32768 to $+32767$. If the addition results in overflow, a value outside of the range -32768 to $+32767$, the results of the addition will be set to the largest possible value, either -32768 or $+32767$. The sign is set to show the direction of the overflow. This function will pass power flow when there is power flow to the enable input and the results of the addition are within the range -32768 to $+32767$ (no overflow).

If discrete memory types are used for parameters P1, P2, and P3 the beginning address must be on a byte boundary.

DPADD Function Description

The three values specified by parameters P1, P2, and P3 must be the same data type (32-bit two's complement signed integers) and must be within the range $-2,147,483,648$ to $+2,147,483,647$. When using the HHP to program a constant into parameters P1 or P2 the constant must be in the range of a single precision number (-32768 to $+32767$).

The memory locations for P1, P2, and P3 are each 32 Bits long. The storage area for each Register, AI and AQ is 16 Bits long, therefore two consecutive registers, AI words, or AQ words must be used for each double precision signed number which is to be stored. The address of the lower of the two registers, AI words, or AQ words is used as the reference to store and retrieve the double precision number.

The HHP can only display a maximum of 16 bits (one register, AI, or AQ word) at a time, therefore a double precision number outside of the range -32768 to $+32767$ cannot be monitored using the HHP. The hexadecimal or binary number for each register, AI, or AQ word can be programmed or monitored provided that they are placed together outside of the CPU to form the 32 Bit double precision signed number.

If the double precision addition results in overflow, a value outside of the range $-2,147,483,648$ to $+2,147,483,647$, the results of the addition will be set to the largest possible value, $-2,147,483,648$ or $+2,147,483,647$. The sign is set to show the direction of the overflow. The DPADD function will pass power flow when there is power flow to the enable input and the results of the addition are within the range $-2,147,483,648$ to $+2,147,483,647$ (no overflow).

$$P1 \text{ (Input 1)} + P2 \text{ (Input 2)} = P3 \text{ (Q)}$$

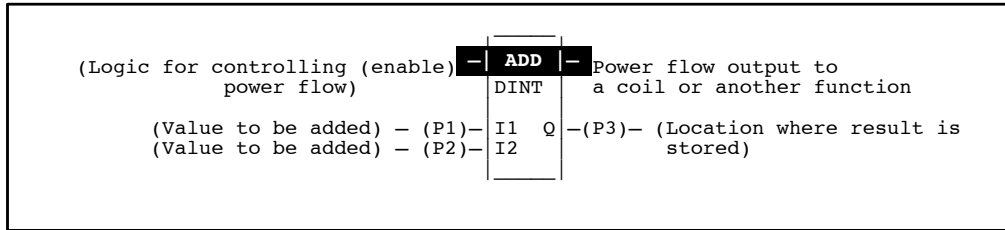

Programming Elements and Sequential Order of Programming

1. Logic controlling the enable input from the left bus. This must start with an LD element.
2. Type of function, either Function 60 (ADD) or Function 61 (DPADD).
3. Parameter P1 (input 1), one of the values to be added. This can be a constant number or a memory location where the value is stored.
4. Parameter P2 (input 2), the other value to be added.
5. Parameter P3 (Q), the memory location where the result is to be stored.

The following tables specify the valid memory types for each of the parameters for the ADD and DPADD functions.

Allowable Memory Types for ADD (Function 60)

Parameter	%I	%Q	%M	%T	%G	%S	%R	%AI	%AQ	Constant
Input 1 (P01)	•	•	•	•	•		•	•	•	•
Input 2 (P02)	•	•	•	•	•		•	•	•	•
Output Q (P03)	•	•	•	•	•		•	•	•	

Allowable Memory Types for DPADD (Function 61)

Parameter	%I	%Q	%M	%T	%G	%S	%R	%AI	%AQ	Constant
Input 1 (P01)							•	•	•	• †
Input 2 (P02)							•	•	•	• †
Output Q (P03)							•	•	•	

† Note that double precision constants are constrained to the range —32,768 to +32,767.

202 Programming Example for Addition

This example of programming uses the DPADD function. In this example a contact from a one shot (OUT +) is used as the controlling element for power flow to the enable function. When input %I0001 closes (passes power flow), %M0001 will pass power flow to the enable input of the ADD function for one sweep of the CPU scan. Therefore, the addition will occur only once. When the additions take place a value located in registers R201 and R202 as indicated by P1 is added to the constant 25 specified by P2. The results of this addition is stored in registers R203 and R204 as specified by P3. If the value of this addition is in the range * 2,147,483,648 to +2,147,483,647 (no overflow) power flow will be passed on to output coil %Q0001 for only one scan of the CPU (only while the enable input has power flow). For example, register 201 has the value of 50 and register 203 has a value of 20 in it before input 1 closes. After input 1 closes the value in register 203 will be 75 (50 + 25 = 75).

Ladder Diagram Representation

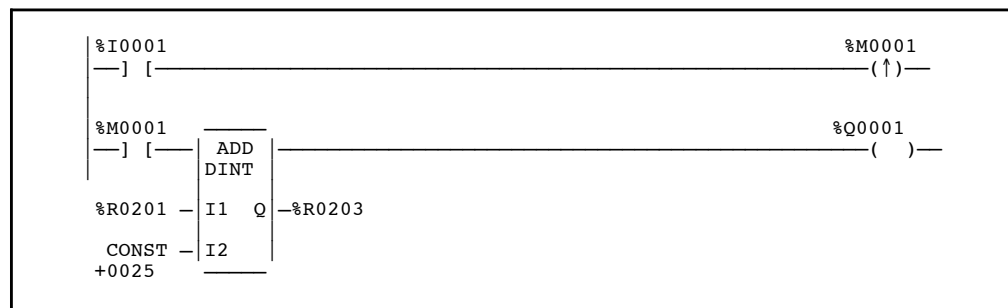

Statement List Representation

```

#0001: LD %I0001
#0002: OUT+ %M0001
#0003: LD %M0001
#0004: FUNC 61 DPADD
      P1: %R201
      P2: 25
      P3: %R203
#0005: OUT %Q0001
  
```

After pressing INS Key: Programming sequence

Key Strokes

HHP Display

Initial display:

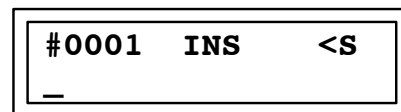

Press the key sequence

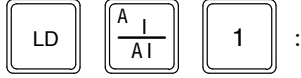

```
#0001  INS  <S  
LD      I 1_
```

Press the  key:

```
#0002  INS  <S  
_
```

Press the key sequence

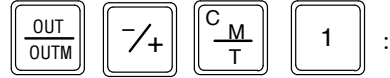

```
#0002  INS  <S  
OUT+   M 1_
```

Press the  key:

```
#0003  INS  <S  
_
```

Press the key sequence

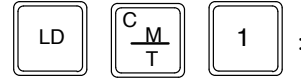

```
#0003  INS  <S  
LD      M 1_
```

Press the  key:

```
#0004  INS  <S  
_
```

Press the key sequence

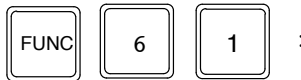

```
#0004  INS  <S  
FUNC 61_ DPADD
```

Press the  key:

```
#0004  DPADD <S  
P01  _
```

Press the key sequence

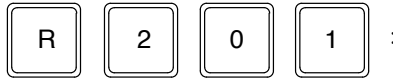

```
#0004 DPADD <S
P01 R 201_
```

Press the



key:

```
#0004 DPADD <S
P02_
```

Press the key sequence



```
#0004 DPADD <S
P02 25
```

Press the



key:

```
#0004 DPADD <S
P03_
```

Press the key sequence



```
#0004 DPADD <S
P03 R 203_
```

Press the



key:

```
#0005 INS <S
_
```

Press the key sequence

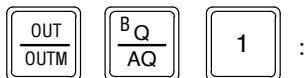

```
#0005 INS <S
OUT Q 1_
```

Press the



key:

```
#0006 INS <S
_
```

Subtraction (SUB) Function 62

Double Precision Subtraction (DPSUB) Function 63

Two subtraction functions are available. The signed subtraction function (SUB) is a conditionally executed function which subtracts one signed integer value from another. The double precision signed subtraction function (DPSUB) is a conditionally executed function which subtracts one signed double word value from another.

When the logic controlling the enable input to the function passes power flow to the enable (EN) input the function is executed by the CPU and a new signed subtraction (for SUB) or double precision signed subtraction (for DPSUB) will take place. During a signed subtraction or double precision signed subtraction execution the value in P2 (input 2) is subtracted from the value in P1 (input 1). The results of this signed or double precision signed subtraction is stored in the memory location specified by P3 (Q). The SUB and DPSUB functions operate on INT (signed integer) and DINT (double precision signed integer) data respectively. The INT SUB function is Function 62 and the DINT SUB function is Function 63.

SUB Function Description

The three values specified by parameters P1, P2, and P3 must be the same data type (16-bit two's complement signed integers) and must be within the range * 32768 to +32767. If the subtraction results in overflow, a value outside of the range * 32768 to +32767, the results of the subtraction will be set to the largest possible value * 32768 or +32767. The sign is set to show the direction of the overflow.

This function will pass power flow when there is power flow to the enable input and the results of the subtraction are within the range * 32768 to +32767 (no overflow). If discrete memory types are used for parameters P1, P2, and P3 the beginning address must be on a byte boundary.

DPSUB Function Description

The three values specified by parameters P1, P2, and P3 must be the same data type (32-bit two's complement signed integers) and must be within the range * 2,147,483,648 to +2,147,483,647. When using the Hand-Held Programmer to program a constant into parameters P1 or P2 the constant must be in the range of a single precision number (* 32768 to +32767).

The memory locations for P1, P2, and P3 are each 32 Bits long. The storage area for each Register, AI and AQ is 16 Bits long, therefore two consecutive registers, AI words or AQ words must be used for each double precision signed number to be stored. The address of the lower of the two registers, AI words, or AQ words is used as the reference to store and retrieve the double precision number.

The Hand-Held Programmer can only display a maximum of 16 bits (one Register, AI, or AQ word) at a time, therefore a double precision number outside of the range * 32768 to +32767 cannot be monitored using the Hand-Held Programmer. The hexadecimal or binary number for each register, AI, or AQ word may be programmed or monitored provided that they are placed together outside of the CPU to form the 32 Bit double precision signed number.

If the subtraction results in overflow, a value outside of the range * 2,147,483,648 to +2,147,483,647, the results of the subtraction will be set to the largest possible value * 2,147,483,648 or +2,147,483,647. The sign is set to show the direction of the overflow. This function will pass power flow when there is power flow to the enable input and the results of the addition are within the range * 2,147,483,648 to +2,147,483,647 (no overflow).

$$P1 (\text{Input 1}) - P2 (\text{Input 2}) = P3 (Q)$$

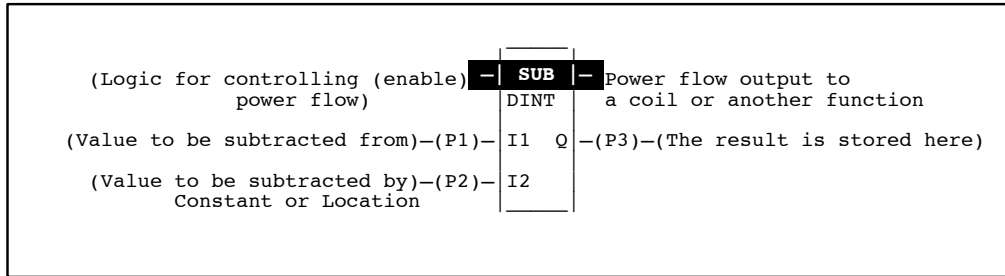

Programming Elements and Sequential Order of Programming

1. Logic controlling the enable input from the left bus. This must start with an LD element.
2. Type of function, either Function 62 (SUB) or Function 63 (DPSUB).
3. Parameter P1 (input 1): value to be subtracted from. This can be a constant number or a memory location where the value is stored.
4. Parameter P2 (input 2): value to be subtracted. This can be a constant number or a memory location where the value is stored.
5. Parameter P3 (Q): memory location where the result is to be stored.

The following tables specify the valid memory types each of the parameters for the SUB and DPSUB functions.

Allowable Memory Types for SUB (Function 62)

Parameter	%I	%Q	%M	%T	%G	%S	%R	%AI	%AQ	Constant
Input 1 (P01)	•	•	•	•	•		•	•	•	•
Input 2 (P02)	•	•	•	•	•		•	•	•	•
Output Q (P03)	•	•	•	•	•		•	•	•	

Allowable Memory Types for DPSUB (Function 63)

Parameter	%I	%Q	%M	%T	%G	%S	%R	%AI	%AQ	Constant
Input 1 (P01)							•	•	•	•†
Input 2 (P02)							•	•	•	•†
Output Q (P03)							•	•	•	

† Note that double precision constants are constrained to the range -32,768 to +32,767.

Programming Example for Subtraction

This example of programming uses the DPSUB function. In this example a contact from a one shot (OUT +) is used as the controlling element for power flow to the enable function. When input %I0001 closes (passes power flow), %M0001 will pass power flow to the enable input of the SUB function for one sweep of the CPU scan. Therefore, the subtraction will occur only once. When the subtraction takes place a decimal number representation of the binary bits located in memory locations AI33 through AI64 as specified by P2 will be subtracted from the value stored in register 200 and 201 as specified by P1. The results will be stored in registers R203 and R204 as specified by P3. If the value of this subtraction is in the range of * 2,147,483,648 to +2,147,483,647 (no overflow) power flow will be passed on to the coil %Q0001 for only one CPU scan (only while the enable input receives power flow). For example, if register 200 has the value of 50 and the decimal value of AI33 through AI64 is 70. After input 1 closes the value in register 203 will be * 20 ($50 - 70 = -20$).

Ladder Diagram Representation

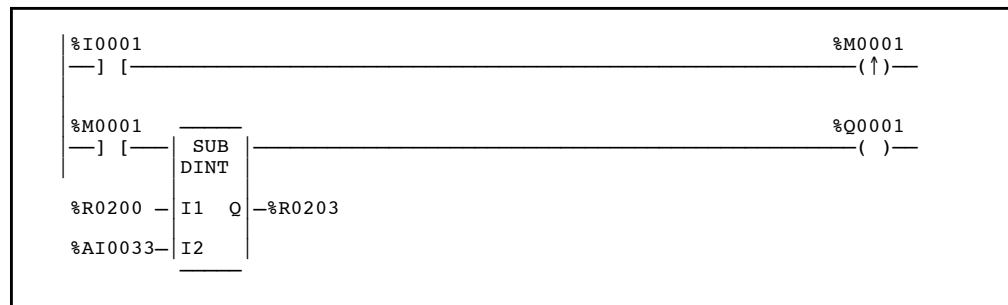

Statement List Representation

```

#0001: LD          %I0001
#0002: OUT+       %M0001
#0003: LD          %M0001
#0004: FUNC      63  DPSUB
                P1: %R200
                P2: %AI33
                P3: %R203
#0005: OUT       %Q0001
  
```

After pressing INS Key: Programming sequence

Key Strokes

HHP Display

Initial display:

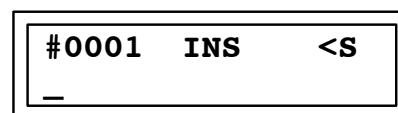

Press the key sequence

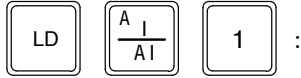

```
#0001  INS  <S
      LD   I 1_
```

Press the  key:

```
#0002  INS  <S
_
```

Press the key sequence

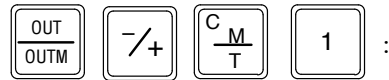

```
#0002  INS  <S
      OUT+  M 1_
```

Press the  key:

```
#0003  INS  <S
_
```

Press the key sequence

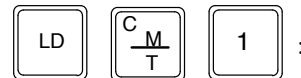

```
#0003  INS  <S
      LD   M 1_
```

Press the  key:

```
#0004  INS  <S
_
```

Press the key sequence



```
#0004  INS  <S
      FUNC 63_  DPSUB
```

Press the  key:

```
#0004  DPSUB <S
      P01 _
```

Press the key sequence

R 2 0 0 :

```
#0004  DPSUB  <S  
P01 R  200_
```

Press the  key:

```
#0004  DPSUB  <S  
P02_
```

Press the key sequence

A I / AI A I / AI 3 3 :

```
#0004  DPSUB  <S  
P02 AI 33_
```

Press the  key:

```
#0004  DPSUB  <S  
P03_
```

Press the key sequence

R 2 0 3 :

```
#0004  DPSUB  <S  
P03 R  203_
```

Press the  key:

```
#0005  INS    <S  
_
```

Press the key sequence

OUT / OUTM B Q / AQ 1 :

```
#0005  INS    <S  
OUT           Q 1_
```

Press the  key:

```
#0006  INS    <S  
_
```

Multiplication (MUL) Function 64

Double Precision Multiplication (DPMUL) Function 65

Two multiplication functions are available. The signed multiplication function (MUL) is a conditionally executed function which multiplies one signed integer word value by another. The double precision signed multiplication function (DPMUL) is a conditionally executed function which multiplies one signed double word value by another.

When the logic controlling the enable input to the function passes power flow to the enable input the function is executed by the CPU and a new signed multiplication (for MUL) or double precision signed multiplication (for DPMUL) will take place. During a signed or double precision signed multiplication execution the value in P1 (input 1) is multiplied by the value in P2 (input 2). The results of this multiplication is stored in the memory location specified by P3 (Q). The MUL and DPMUL functions operate on INT (signed integer) and DINT (double precision integer) data respectively. The INT MUL function is Function 64 and the DINT MUL function is Function 65.

MUL Function Description

The three values specified by parameters P1, P2, and P3 must be the same data type (16-bit two's complement signed integers) and must be within the range * 32768 to +32767. If the signed multiplication results in overflow, a value outside of the range * 32768 to +32767, the results of the multiplication will be set to the largest possible value * 32768 or +32767. The sign is set to show the direction of the overflow.

This function will pass power flow when there is power flow to the enable input and the results of the multiplication are within the range * 32768 to +32767 (no overflow).

If discrete memory types are used for parameters P1, P2, and P3 the beginning address must be on a byte boundary.

DPMUL Function Description

The three values specified by parameters P1, P2, and P3 must be the same data type (32-bit two's complement signed integers) and must be within the range * 2,147,483,648 to +2,147,483,647. When using the Hand-Held Programmer to program a constant into parameters P1 or P2 the constant must be in the range of a single precision number (* 32768 to +32767).

The memory locations for P1, P2, and P3 are each 32 Bits long. The storage area for each Register, AI and AQ is 16 Bits long, therefore two consecutive registers, AI words or AQ words must be used for each double precision signed number which is to be stored. The address of the lower of the two registers, AI words, or AQ words is used as the reference to store and retrieve the double precision number.

The Hand-Held Programmer can only display a maximum of 16 bits (one Register, AI, or AQ word) at a time, therefore a double precision number outside of the range * 32768 to +32767 cannot be monitored using the Hand-Held Programmer. The hexadecimal or binary number for each register, AI, or AQ word may be programmed or monitored provided that they are placed together outside of the CPU to form the 32 Bit double precision signed number.

If the multiplication results in overflow, a value outside of the range -2,147,483,648 to +2,147,483,647, the results of the multiplication will be set to the largest possible value -2,147,483,648 or +2,147,483,647. The sign is set to show the direction of the overflow. This function will pass power flow when there is power flow to the enable input and the results of the multiplication are within the range -2,147,483,648 to +2,147,483,647 (no overflow).

$$P1 \text{ (Input 1)} \times P2 \text{ (Input 2)} = P3 \text{ (Q)}$$

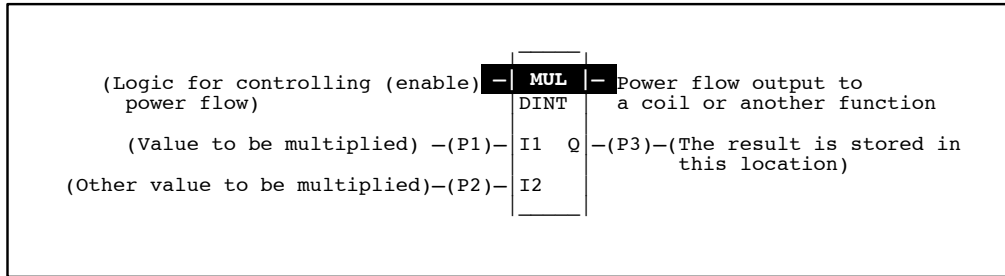

Programming Elements and Sequential Order of Programming

1. Logic controlling the enable input from the left bus. This must start with an LD element.
2. Type of function, either Function 64 (MUL) or Function 65 (DPMUL).
3. Parameter P1 (input 1): value to be multiplied. This can be a constant number or a memory location where the value is stored.
4. Parameter P2 (input 2): the other value being multiplied. This can be a constant number or a memory location where the value is stored.
5. Parameter P3 (Q): memory location where the result is to be stored.

The following tables specify which memory types are valid for each of the parameters for the MUL and DPMUL functions.

Allowable Memory Types for MUL (Function 64)

Parameter	%I	%Q	%M	%T	%G	%S	%R	%AI	%AQ	Constant
Input 1 (P01)	•	•	•	•	•		•	•	•	•
Input 2 (P02)	•	•	•	•	•		•	•	•	•
Output Q (P03)	•	•	•	•	•		•	•	•	

Allowable Memory Types for DPMUL (Function 65)

Parameter	%I	%Q	%M	%T	%G	%S	%R	%AI	%AQ	Constant
Input 1 (P01)							•	•	•	•†
Input 2 (P02)							•	•	•	•†
Output Q (P03)							•	•	•	

† Note that double precision constants are constrained to the range * 32,768 to +32,767.

Programming Example for Multiplication

This programming example uses the DPMUL function. In this example a contact from a one shot (OUT +) is used as the controlling element for the power flow to the enable input of the multiply function. When input %I0001 closes (passes power flow), %M0001 will pass power flow to the enable input of the multiply function for only one sweep of the CPU scan. Therefore, the multiplication will only occur once each time input 1 is closed. When the multiplication takes place a value located in registers 199 and 200 as specified by P1 is multiplied by the value located in registers 201 and 202 as specified by P2. The results of this multiplication is stored in registers 203 and 204 as specified by P3. If the value of this multiplication is in the range * 2,147,483,648 to +2,147,483,647 power flow will be passed on to the output coil %Q0001 for only one scan of the CPU (only while the enable input has power flow). For example, if register 199 has a value of 75 in it and register 201 has a value of 20 in it, after input 1 closes the value in register 203 will be 1500 (75 x 20 = 1500).

Ladder Diagram Representation

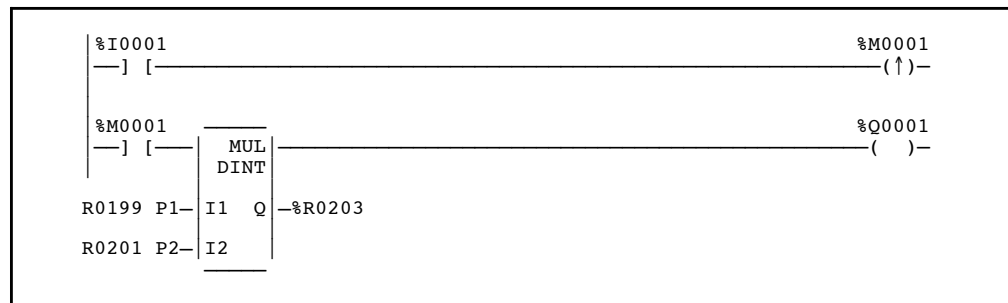

Statement List Representation

#0001:	LD	%I0001
#0002:	OUT+	%M0001
#0003:	LD	%M0001
#0004:	FUNC	65 DPMUL
		P1: %R0199
		P2: %R0201
		P3: %R0203
#0005:	OUT	%Q0001

After pressing INS Key: Programming sequence

Key Strokes

HHP Display

Initial display:

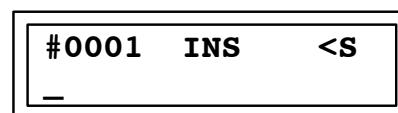

Press the key sequence

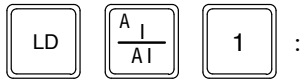

```
#0001  INS  <S  
LD      I 1_
```

Press the  key:

```
#0002  INS  <S  
_
```

Press the key sequence

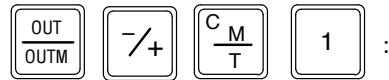

```
#0002  INS  <S  
OUT+   M 1_
```

Press the  key:

```
#0003  INS  <S  
_
```

Press the key sequence

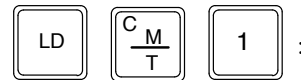

```
#0003  INS  <S  
LD      M 1_
```

Press the  key:

```
#0004  INS  <S  
_
```

Press the key sequence



```
#0004  INS  <S  
FUNC   65_ DPMUL
```

Press the  key:

```
#0004  DPMUL <S  
P01  _
```

Press the key sequence

R **1** **9** **9** :

```
#0004 DPMUL <S
P01 R 199_
```

Press the  key:

```
#0004 DPMUL <S
P02_
```

Press the key sequence

R **2** **0** **1** :

```
#0004 DPMUL <S
P02 R 201_
```

Press the  key:

```
#0004 DPMUL <S
P03_
```

Press the key sequence



R **2** **0** **3** :

```
#0004 DPMUL <S
P03 R 203_
```

Press the  key:

```
#0005 INS <S
_
```

Press the key sequence

  **1** :

```
#0005 INS <S
OUT Q 1_
```

Press the  key:

```
#0006 INS <S
_
```

Division (DIV) Function 66

Double Precision Division (DPDIV) Function 67

Two division functions are available. The signed division function (DIV) is a conditionally executed function which divides one signed word value by another and gives only the quotient as the result. The double precision signed division function (DPDIV) is a conditionally executed function which divides one signed double word value by another and gives only the quotient as a result.

When the logic controlling the enable input to the function passes power flow to the enable input the function is executed by the CPU and a new signed division (for DIV) or double precision signed division (for DPDIV) will take place. During a signed division or double precision signed division execution the value in P1 (input 1) is divided by the value in P2 (input 2). The results of this signed division is the quotient only (the remainder is lost) and is stored in the memory location specified by P3 (Q). To obtain the remainder use the Modulo Division Function 68 (for signed division) or Double precision Modulo Division Function 69 (for double precision division). Functions 68 and 69 find only the remainder and the quotient is lost.

DIV Function Description

The three values specified by parameters P1, P2, and P3 must be the same data type (16-bit two's complement signed integers) and must be within the range * 32768 to +32767. If an attempt to divide by zero is made the quotient will be set to either * 32768 or +32767 depending on the sign of the number being divided and no power flow will pass through this function.

This function will pass power flow when there is power flow to the enable input and no attempt has been made to divide by zero. If discrete memory types are used for parameters P1, P2, and P3 the beginning address must be on a byte boundary.

DPDIV Function Description

The three values specified by parameters P1, P2, and P3 must be the same data type (32-bit two's complement signed integers) and must be within the range * 2,147,483,648 to +2,147,483,647. When using the Hand-Held Programmer to program a constant into parameters P1 or P2 the constant must be in the range of a single precision number (* 32768 to +32767).

The memory locations for P1, P2, and P3 are each 32 Bits long. The storage area for each Register, AI and AQ is 16 Bits long, therefore two consecutive registers, AI words or AQ words must be used for each double precision signed number which is to be stored. The address of the lower of the two registers, AI words, or AQ words is used as the reference to store and retrieve the double precision number.

The Hand-Held Programmer can only display a maximum of 16 bits (one Register, AI, or AQ word) at a time, therefore a double precision number outside of the range * 32768 to +32767 can not be monitored using the Hand-Held Programmer. The hexadecimal or binary number for each register, AI, or AQ word may be programmed or monitored provided that they are placed together outside of the CPU to form the 32 Bit double precision signed number.

If the division results in overflow, a value outside of the range * 2,147,483,648 to +2,147,483,647, the results of the division will be set to the largest possible value * 2,147,483,648 or +2,147,483,647. The sign is set to show the direction of the overflow. This function will pass power flow when there is power flow to the enable input and the

results of the division are within the range * 2,147,483,648 to +2,147,483,647 (no overflow).

To prevent multiple divisions from taking place, it is advisable to have the power flow to the enable input controlled by a contact from a one shot element (OUT+ or OUT*).

$$*P1 \text{ (Input 1) } \div P2 \text{ (Input 2)} = P3 \text{ (Q) quotient}$$

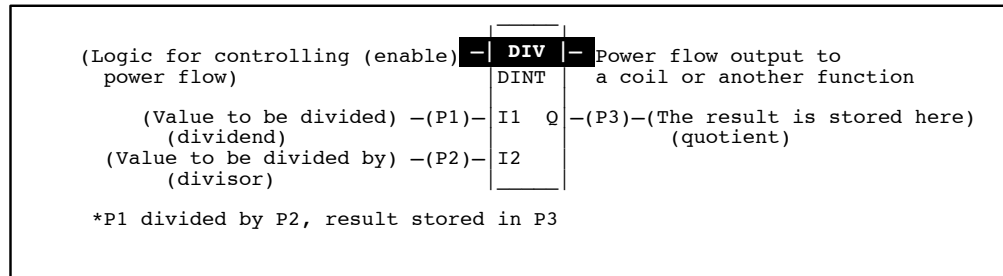

Programming Elements and Sequential Order of Programming

1. Logic controlling the enable input from the left bus. This must start with an LD element.
2. Type of function, either Function 66 (DIV) or Function 67 (DPDIV).
3. Parameter P1 (input 1): value to be divided (dividend). This can be a constant number or a memory location where the value is stored.
4. Parameter P2 (input 2): the divisor. This can be a constant number or a memory location where the value is stored.
5. Parameter P3 (Q): memory location where the result (quotient) is to be stored.

The following tables specify which memory types are valid for each of the parameters for the DIV and DPDIV functions.

Allowable Memory Types for DIV (Function 66)

Parameter	%I	%Q	%M	%T	%G	%S	%R	%AI	%AQ	Constant
Input 1 (P01)	•	•	•	•	•		•	•	•	•
Input 2 (P02)	•	•	•	•	•		•	•	•	•
Output Q (P03)	•	•	•	•	•		•	•	•	

Allowable Memory Types for DPDIV (Function 67)

Parameter	%I	%Q	%M	%T	%G	%S	%R	%AI	%AQ	Constant
Input 1 (P01)							•	•	•	• †
Input 2 (P02)							•	•	•	• †
Output Q (P03)							•	•	•	

† Note that double precision constants are constrained to the range * 32,768 to +32,767.

Programming Example for Division

This example of programming uses the DPDIV function. In this example a contact from a one shot (OUT +) is used as the controlling element for the power flow to the enable input of the divide function. When input %I0001 closes (passes power flow), %M0001 will pass power flow to the enable input of the divide function for only one sweep of the CPU scan. Therefore, the division will only occur once each time input 1 is closed. When the division takes place a value located in registers 199 and 200 as specified by P1 is divided by the value located in registers 201 and 202 as specified by P2. The results of this division is stored in registers 203 and 204 as specified by P3. If the value in register 201 is not zero (divide by zero) power flow will be passed through this function to turn on output Q1 for only one CPU scan (only while the enable input has power flow. For example, if register 199 and 200 has a value of 50 and register 201 and 202 has a value of 4 then register 203 and 204 will have a value of 12 after input 1 is closed. $50 \text{ B } 4 = 12.50$, only the quotient is given as a result of this division.

Ladder Diagram Representation

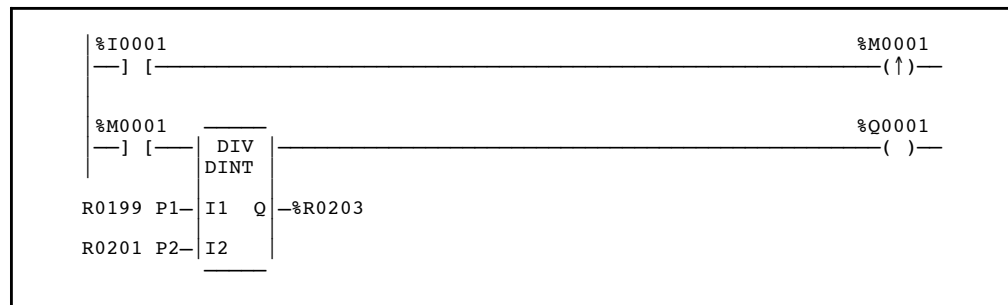

Statement List Representation

#0001: LD	%I0001
#0002: OUT+	%M0001
#0003: LD	%M0001
#0004: FUNC	67 DPDIV
	P1: %R0199
	P2: %R0201
	P3: %R0203
#0005: OUT	%Q0001

After pressing INS Key: Programming sequence

Key Strokes

HHP Display

Initial display:

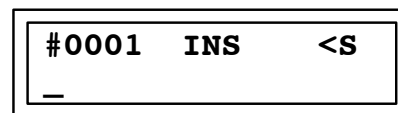

Press the key sequence

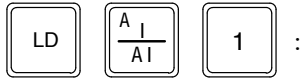

```
#0001  INS  <S  
LD      I 1_
```

Press the  key:

```
#0002  INS  <S  
_
```

Press the key sequence

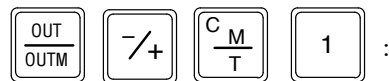

```
#0002  INS  <S  
OUT+   M 1_
```

Press the  key:

```
#0003  INS  <S  
_
```

Press the key sequence

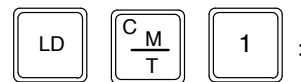

```
#0003  INS  <S  
LD      M 1_
```

Press the  key:

```
#0004  INS  <S  
_
```

Press the key sequence

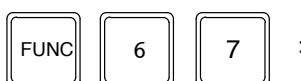

```
#0004  INS  <S  
FUNC 67_  DPDIV
```

Press the  key:

```
#0004  DPDIV <S  
P01  _
```

Press the key sequence

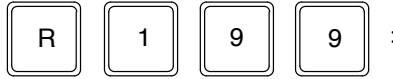

```
#0004 DPDIV <S  
P01 R 199_
```

Press the  key:

```
#0004 DPDIV <S  
P02_
```

Press the key sequence

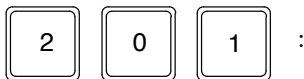

```
#0004 DPDIV <S  
P02 R 201_
```

Press the  key:

```
#0004 DPDIV <S  
P03_
```

Press the key sequence

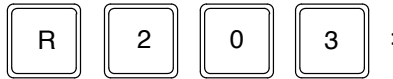

```
#0004 DPDIV <S  
P03 R 203_
```

Press the  key:

```
#0005 INS <S  
_
```

Press the key sequence

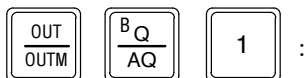

```
#0005 INS <S  
OUT Q 1_
```

Press the  key:

```
#0006 INS <S  
_
```

Modulo Division (MOD) Function 68

Double Precision Modulo Division (DPMOD) Function 69

Two modulo division functions are available. Division and modulo division are similar functions which differ only in their output; division finds a quotient, while modulo division finds a remainder. The signed modulo division function (MOD) is a conditionally executed function which modulo divides one signed word value by another. The double precision signed modulo division function (DPMOD) is a conditionally executed function which modulo divides one signed double word value by another.

When the logic controlling the enable input to the function passes power flow to the enable (EN) input the function is executed by the CPU and a new signed division (for MOD) or double precision signed division (for DPMOD) will take place. During a signed division or double precision signed division execution the value in P1 (input 1) is divided by the value in P2 (input 2). The result of this signed division is the remainder only (the quotient is lost) and is stored in the memory location specified by P3 (Q). To obtain the quotient use the DIV Function 66 (for signed division) or DPDIV Function 67 (for double precision signed division). Functions 66 and 67 find only the quotient; the remainder is lost.

MOD Function Description

The three values specified by parameters P1, P2, and P3 must be the same data type (16-bit two's complement signed integers) and must be within the range * 32768 to +32767. If an attempt to divide by zero is made the remainder will be set to either * 32768 or +32767 depending on the sign of the number being divided and no power flow will pass through this function.

This function will pass power flow when there is power flow to the enable input and no attempt has been made to divide by zero. If discrete memory types are used for parameters P1, P2, and P3 the beginning address must be on a byte boundary.

DPMOD Function Description

The three values specified by parameters P1, P2, and P3 must be the same data type (32-bit two's complement signed integers) and must be within the range * 2,147,483,648 to +2,147,483,647. When using the Hand-Held Programmer to program a constant into parameters P1 or P2 the constant must be in the range of a single precision number (* 32768 to +32767).

The memory locations for P1, P2, and P3 are each 32 Bits long. The storage area for each Register, AI and AQ is 16 Bits long, therefore two consecutive registers, AI words or AQ words must be used for each double precision signed number which is to be stored. The address of the lower of the two registers, AI words, or AQ words is used as the reference to store and retrieve the double precision number.

The Hand* Held Programmer can only display a maximum of 16 bits (one Register, AI, or AQ word) at a time, therefore a double precision number outside of the range * 32768 to +32767 can not be monitored using the Hand* Held Programmer. The hexadecimal or binary number for each register, AI, or AQ word may be programmed or monitored provided that they are placed together outside of the CPU to form the 32 Bit double precision signed number.

If the division results in overflow, a value outside of the range * 2,147,483,648 to +2,147,483,647, the result of the division will be set to the largest possible value * 2,147,483,648 or +2,147,483,647. The sign is set to show the direction of the overflow. This function will pass power flow when there is power flow to the enable input and the results of the division are within the range * 2,147,483,648 to +2,147,483,647 (no overflow).

$$*P1 \text{ (Input 1)} \text{ B } P2 \text{ (Input 2)} = P3 \text{ (Q) Remainder}$$

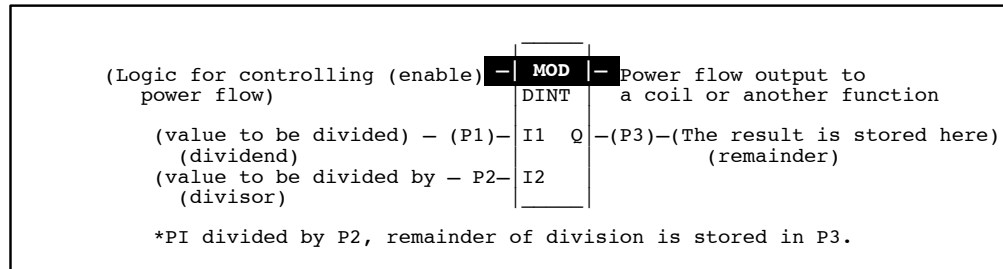

Programming Elements and Sequential Order of Programming

1. Logic controlling the enable input from the left bus. This must start with an LD element.
2. Type of function, either Function 68 (MOD) or Function 69 (DPMOD).
3. Parameter P1 (input 1): value to be divided (dividend). This can be a constant number or a memory location where the value is stored.
4. Parameter P2 (input 2): the divisor. This can be a constant number or a memory location where the value is stored.
5. Parameter P3 (Q): memory location where the result (remainder) is to be stored.

The following tables specify which memory types are valid for each of the parameters for the MOD and DPMOD functions.

Allowable Memory Types for MOD (Function 68)

Parameter	%I	%Q	%M	%T	%G	%S	%R	%AI	%AQ	Constant
Input 1 (P01)	•	•	•	•	•		•	•	•	•
Input 2 (P02)	•	•	•	•	•		•	•	•	•
Output Q (P03)	•	•	•	•	•		•	•	•	

Allowable Memory Types for DPMOD (Function 69)

Parameter	%I	%Q	%M	%T	%G	%S	%R	%AI	%AQ	Constant
Input 1 (P01)							•	•	•	•†
Input 2 (P02)							•	•	•	•†
Output Q (P03)							•	•	•	

† Note that double precision constants are constrained to the range —32,768 to +32,767.

Programming Example for Modulo Division

This example of programming uses the DPMOD function. In this example a contact from a one shot (OUT +) is used as the controlling element for the power flow to the enable input of the divide function. When input %I0001 closes (passes power flow), %M0001 will pass power flow to the enable input of the DPMOD function for only one sweep of the CPU scan. Therefore, the division will only occur once each time input 1 is closed. When the division takes place a value located in registers 199 and 200 as specified by P1 is divided by the value located in registers 201 and 202 as specified by P2. The remainder of this division is stored in registers 203 and 204 as specified by P3. If the value in register 201 is not zero (divide by zero) power flow will be passed through this function to turn on output Q1 for only one CPU scan (only while the enable input has power flow. For example, if register 199 and 200 has a value of 50 and register 201 and 202 has a value of 4 then register 203 and 204 will have a value of 2 after input 1 is closed. $50 \div 4 = 12.50$, only the remainder is given as a result of this division.

($50 \div 4 = 12.50$, $12 \times 4 = 48$, $50 - 48 = 2$ remainder)

Ladder Diagram Representation

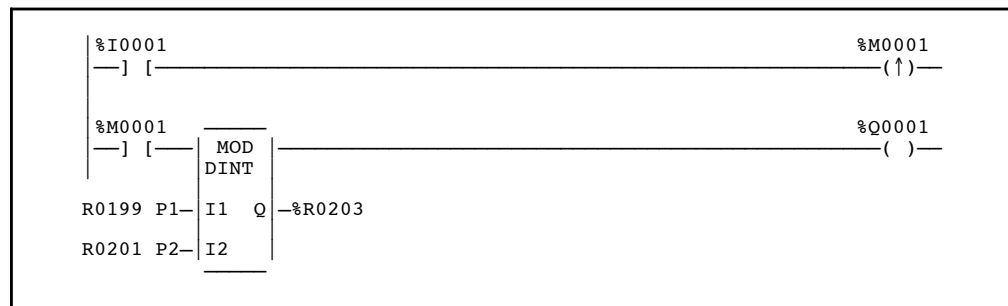

Statement List Representation

```

#0001:      LD          %I0001
#0002:      OUT+       %M0001
#0003:      LD          %M0001
#0004:      FUNC      69      DPMOD
                    P1:    %R0199
                    P2:    %R0201
                    P3:    %R0203
#0005:      OUT          %Q0001
    
```

After pressing  Key: Programming sequence



Key Strokes

HHP Display

Initial display:

```
#0001  INS  <S
_
```

Press the key sequence





   :

```
#0001  INS  <S
LD      I 1_
```

Press the  key:

```
#0002  INS  <S
_
```

Press the key sequence



    :

```
#0002  INS  <S
OUT+    M 1_
```

Press the  key:

```
#0003  INS  <S
_
```

Press the key sequence



   :

```
#0003  INS  <S
LD      M 1_
```

Press the  key:

```
#0004  INS  <S
_
```

Press the key sequence





   :

```
#0004  INS  <S
FUNC 69_  DPMOD
```

Press the  key:

```
#0004 DPMOD <S  
P01 _
```

Press the key sequence

    :

```
#0004 DPMOD <S  
P01 R 199_
```

Press the  key:

```
#0004 DPMOD <S  
P02_
```

Press the key sequence

    :

```
#0004 DPMOD <S  
P02 R 201_
```

Press the  key:

```
#0004 DPMOD <S  
P03_
```

Press the key sequence



    :

```
#0004 DPMOD <S  
P03 R 203_
```

Press the  key:

```
#0005 INS <S  
_
```

Press the key sequence

   :

```
#0005 INS <S  
OUT Q 1_
```

Press the  key:

```
#0006 INS <S  
_
```

Square Root, INT (SQRT) Function 70

Square Root, DINT (DPSQRT) Function 71

The Square Root (SQRT) function is a conditionally executed function which is used to find the square root of an integer value. When the function receives power flow to the enable input, the value of output Q (P2) is set to the integer portion of the square root of the input IN (P1) value whose square root is to be calculated. The output Q must be the same data type as IN. The IN parameter must be a constant or reference for the value on which the square root is to be calculated.

The SQRT function operates on two types of data: INT (signed integer) and DINT (double-precision integer). The INT Square Root function is function number 70 and the DINT Square Root function is function number 71.

OK is set to true if the function is performed without overflow; otherwise, ok is set false.

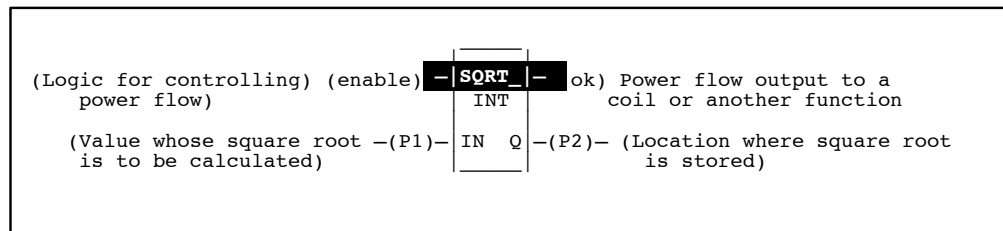

Programming Elements and Sequential Order of Programming

1. Logic controlling the enable input from the left bus. This must start with an LD element.
2. Type of function, either Function 70 (SQRT) or Function 71 (DPSQRT).
3. Parameter P1 (IN): value whose square root is to be calculated. This can be a constant number or a memory location where the value is stored.
4. Parameter P2 (Q): the location where the integer portion of the square root of input (IN) is stored. This can be a constant number or a memory location where the value is stored.

The following tables specify which memory types are valid for each of the SQRT and DPSQRT function parameters.

Allowable Memory Types for SQRT (Function 70)

Parameter	flow	%I	%Q	%M	%T	%S	%G	%R	%AI	%AQ	const	none
enable	•											
IN (P01)		•	•	•	•		•	•	•	•	•‡	
ok	•											•
Q (P02)		•	•	•	•		•	•	•	•		

• = Valid reference or place where power may flow through the function.
 ‡ = Constants are limited to integer values for double integer operations.

Allowable Memory Types for DPSQRT (Function 71)

Parameter	flow	%I	%Q	%M	%T	%S	%G	%R	%AI	%AQ	const	none
enable	•											
IN (P01)								•	•	•	•‡	
ok	•											•
Q (P02)								•	•	•		

- = Valid reference or place where power may flow through the function.
- ‡ = Constants are limited to integer values for double integer operations.

Programming Example for Square Root Function

In the following example, the square root of the constant (180) is calculated. When input %S0005 closes (passes power flow), the SQRT function is executed. The value 13 which represents the integer portion of the result will be placed in %AI001 and the OK output will be set to TRUE.

Ladder Diagram Representation

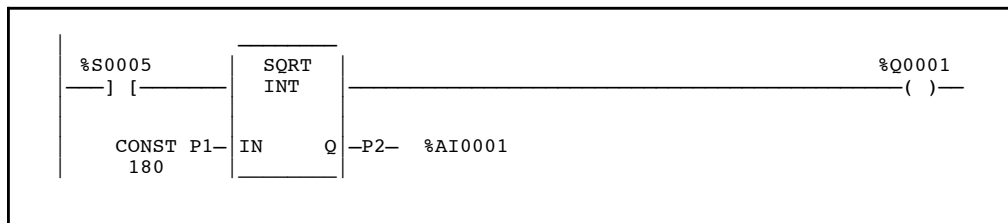

Statement List Representation

```

#0001: LD      %S0005
#0002: FUNC   70  SQRT
          P01: 180
          P02: %AI001
#0003: OUT   %Q0001
    
```

After pressing INS Key: Programming sequence

Key Strokes

HHP Display

Initial display:

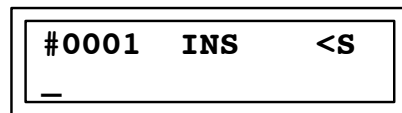

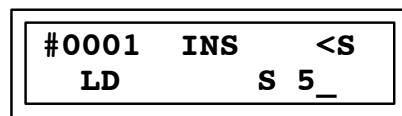

Press the key sequence



Press the  key:

```
#0002  INS  <S  
_
```

Press the key sequence

   :

```
#0002  INS  <S  
FUNC  70_ SQRT
```

Press the  key:

```
#0002  SQRT  <S  
P01  _
```

Press the key sequence



   :

```
#0002  SQRT  <S  
P01  180_
```

Press the  key:

```
#0002  SQRT  <S  
P02  _
```

Press the key sequence



   :

```
#0002  SQRT  <S  
P02  AI  1_
```

Press the  key:

```
#0003  INS  <S  
_
```

Press the key sequence

   :

```
#0003  INS  <S  
OUT      Q  1_
```

Press the  key:

```
#0004  INS  <S  
_
```

Section 3: Relational Functions

Relational functions are used to compare two numbers of the same data type which can be either single or double precision integers. When the function receives power flow to the enable input, the function is executed and it compares the value I1 to the value I2. These values must be the same data type. The following relational functions are described in this section:

Abbreviation	Function	Description
EQ DPEQ	Equal Double Precision Equal	Test two signed word numbers for equality. Test two signed double word numbers for equality.
NE DPNE	Not Equal Double Precision Not Equal	Test two signed word numbers for non-equality. Test two signed double word numbers for non-equality.
GT DPGT	Greater Than Double Precision Greater Than	Test for one signed word number greater than another. Test for one signed double word number greater than another.
GE DPGE	Greater Than or Equal Double Precision Greater Than or Equal	Test for one signed word number greater than or equal to another. Test for one signed double word number greater than or equal to another.
LT DPLT	Less Than Double Precision Less Than	Test for one signed word number less than another. Test for one signed double word number less than another.
LE DPLE	Less Than or Equal Double Precision Less Than or Equal	Test for one signed word number less than or equal to another. Test for one signed double word number less than or equal to another.
RANGI RANGDI RANGW	Integer Range Double Precision Range Word range	Test for an integer to be within a specified range. Test for a double word value to be within a specified range. Test for a word value to be within a specified range.

Each of the relational functions is described in this section.

Equal (EQ) Function 52

Double Precision Equal (DPEQ) Function 72

Two equal functions are available. The equal test (EQ) is a conditionally executed function which tests for one signed word value equal to another. The double precision equal test (DPEQ) is a conditionally executed function which tests for one signed double word value equal to another.

When the logic controlling the enable input to the function passes power flow to this functions enable input the function is executed by the CPU and a new comparison will take place. During the execution of an equal comparison the signed value (for EQ) or double precision signed value (for DPEQ) in P1 (input 1) is compared to see if it is equal to the signed (for EQ) or double precision signed (for DPEQ) value in P2 (input 2). If the comparison is equal power flow will pass to a coil or another function. The difference in the two functions is that the EQ function operates on INT (signed integer) values and the DPEQ function operates on DINT (double precision signed) values. The INT EQ function is Function 52 and the DINT EQ function is Function 72.

EQ Function Description

The two values specified by parameters P1 and P2, must be the same data type (16-bit two's complement signed integers) and must be within the range * 32768 to +32767.

This function will pass power flow when there is power flow to the enable input and the value specified by parameter P1 is equal to the value specified by parameter P2.

If discrete memory types are used for parameters P1 and P2 the beginning address must be on a byte boundary.

DPEQ Function Description

The two values specified by parameters P1 and P2, must be the same data type (32-bit two's complement signed integers) and must be within the range * 2,147,483,648 to +2,147,483,647. When using the Hand-Held Programmer to program a constant into parameters P1 or P2 the constant must be in the range of a single precision number (-32768 to +32767).

The memory locations for P1 and P2 are each 32 Bits long. The storage area for each Register, AI and AQ is 16 Bits long, therefore two consecutive registers, AI words or AQ words must be used for each double precision signed number which is to be stored. The address of the lower of the two registers, AI words, or AQ words is used as the reference to store and retrieve the double precision number.

The Hand-Held Programmer can only display a maximum of 16 bits (one Register, AI, or AQ word) at a time, therefore a double precision number outside of the range * 32768 to +32767 cannot be programmed into the CPU or monitored using the Hand-Held Programmer. The hexadecimal or binary number for each register, AI, or AQ word can be programmed in or monitored provided that they are placed together outside of the CPU to form the 32 Bit double precision signed number.

This function will pass power flow when there is power flow to the enable input and the value specified by parameter P1 is equal to the value specified by parameter P2.

P1 (Input 1) = P2 (Input 2)

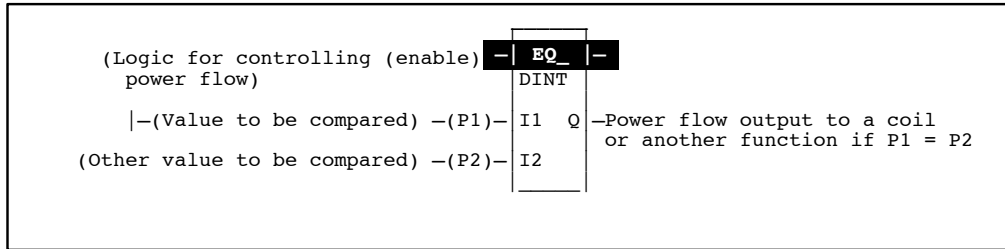

Programming Elements and Sequential Order of Programming

1. Logic controlling the enable input from the left bus. This must start with an LD element.
2. Type of function, either Function 52 (EQ) or Function 72 (DPEQ).
3. Parameter P1 (input 1): one of the values to be compared. This can be a constant number or a memory location where the value is stored.
4. Parameter P2 (input 2): the other value to be compared. This can be a constant number or a memory location where the value is stored.

The following tables specify which memory types are valid for each of the parameters for the EQ and DPEQ functions.

Allowable Memory Types for EQ (Function 52)

Parameter	%I	%Q	%M	%T	%G	%S	%R	%AI	%AQ	Constant
Input 1 (P01)	•	•	•	•	•		•	•	•	•
Input 2 (P02)	•	•	•	•	•		•	•	•	•

Allowable Memory Types for DPEQ (Function 72)

Parameter	%I	%Q	%M	%T	%G	%S	%R	%AI	%AQ	Constant
Input 1 (P01)							•	•	•	•†
Input 2 (P02)							•	•	•	•†

† Note that double precision constants are constrained to the range * 32,768 to +32,767.

Programming Example for Equal Function

This example of programming uses the EQ function. In this example when input %I0001 is closed (passing power to the enable input) the data located in the 16 bits of register 250 (parameter P1) is compared to the data represented by the 16 bits of the discrete input I17 through I32 (parameter P2= I17). If these two values are equal then power flow will be passed onto output coil %Q0001.

For example, assume that the value in register 250 is decimal value 156 which is 0000000010011100 in binary. In order to have power flow pass through this function when %I0001 is closed the discrete inputs I19, I20, I21 and I24 must also be on (this makes the binary data in inputs 17 through 32 equal to the binary data stored in register 250).

Condition of Inputs	0	0	0	0	0	0	0	0	1	0	0	1	1	1	0	0
InputNumber	32	31	30	29	28	27	26	25	24	23	22	21	20	19	18	17

0 = OFF (no power flow) 1 = ON (power flow)

Ladder Diagram Representation



Statement List Representation

```
#0001: LD      %I0001
#0002: FUNC   52  EQ
          P1:  %R0250
          P2:  %I0017
#0003: OUT    %Q0001
```

After pressing INS Key: Programming sequence

Key Strokes

HHP Display

Initial display:

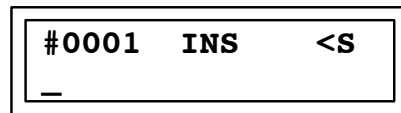

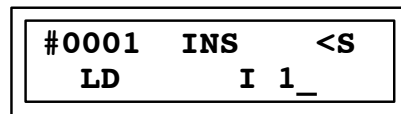
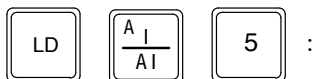

Press the key sequence



Press the  key:

```
#0002  INS  <S  
_
```

Press the key sequence

   :

```
#0002  INS  <S  
FUNC  52_ EQ
```

Press the  key:

```
#0002  EQ   <S  
P01  _
```

Press the key sequence

    :

```
#0002  EQ   <S  
P01  R 250_
```

Press the  key:

```
#0002  EQ   <S  
P02  _
```

Press the key sequence



   :

```
#0002  EQ   <S  
P02  I 17_
```

Press the  key:

```
#0003  INS  <S  
_
```

Press the key sequence

   :

```
#0003  INS  <S  
OUT           Q 1_
```

Press the  key:

```
#0004  INS  <S  
_
```

Not Equal Comparison (NE) Function 53

Double Precision Not Equal Comparison (DPNE) Function 73

Two not equal test functions are available. The not equal test (NE) is a conditionally executed function which tests for one signed word value not equal to another. The double precision not equal test (DPNE) is a conditionally executed function which tests for one signed double word value not equal to another.

When the logic controlling the enable input to the function passes power flow to the enable input the function is executed by the CPU and a new comparison (for NE) or double precision signed comparison (for DPNE) will take place. During the execution of a not equal comparison or double precision signed comparison the signed value in P1 (input 1) is compared to see if it is not equal to the signed value in P2 (input 2). If the comparison is not equal power flow is passed. The NE and DPNE functions operate on INT (signed integer) and DINT (double precision signed integer) data respectively. The INT NE function is Function 53 and the DINT NE function is Function 73.

NE Function Description

The two values specified by parameters P1 and P2, must be the same data type (16-bit two's complement signed integers) and must be within the range * 32768 to +32767.

This function will pass power flow when there is power flow to the enable input and the value specified by parameter P1 is not equal to the value specified by parameter P2.

If discrete memory types are used for parameters P1 and P2 the beginning address must be on a byte boundary.

DPNE Function Description

The two values specified by parameters P1 and P2, must be the same data type (32-bit two's complement signed integers) and must be within the range * 2,147,483,648 to +2,147,483,647. When using the Hand* Held Programmer (HHP) to program a constant into parameters P1 or P2 the constant must be in the range of a single precision number (* 32768 to +32767).

The memory locations for P1 and P2 are each 32 Bits long. The storage area for each Register, AI and AQ is 16 Bits long, therefore two consecutive registers, AI words or AQ words must be used for each double precision signed number which is to be stored. The address of the lower of the two registers, AI words, or AQ words is used as the reference to store and retrieve the double precision number.

The Hand* Held Programmer can only display a maximum of 16 bits (one Register, AI, or AQ word) at a time, therefore a double precision number outside of the range * 32768 to +32767 cannot be programmed into the CPU or monitored using the Hand* Held Programmer. The hexadecimal or binary number for each register, AI, or AQ word can be programmed into the CPU or monitored provided that they are placed together outside of the CPU to form the 32 Bit double precision signed number.

This function will pass power flow when there is power flow to the enable input and the value specified by parameter P1 is not equal to the value specified by parameter P2.

*P1 (Input 1) ≠ P2 (Input 2)

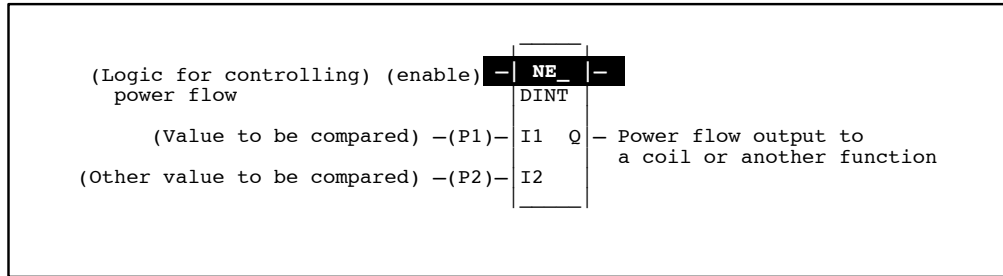

* 0 means not equal to

Programming Elements and Sequential Order of Programming

1. Logic controlling the enable input from the left bus. This must start with an LD element.
2. Type of function, either Function 53 (NE) or Function 73 (DPNE).
3. Parameter P1 (input 1): one of the values to be compared. This can be a constant number or a memory location where the value is stored.
4. Parameter P2 (input 2): the other value to be compared. This can be a constant number or a memory location where the value is stored.

The following tables specify which memory types are valid for each of the NE and DPNE function parameters:

Allowable Memory Types for NE (Function 53)

Parameter	%I	%Q	%M	%T	%G	%S	%R	%AI	%AQ	Constant
Input 1 (P01)	•	•	•	•	•		•	•	•	•
Input 2 (P02)	•	•	•	•	•		•	•	•	•

Allowable Memory Types for DPNE (Function 73)

Parameter	%I	%Q	%M	%T	%G	%S	%R	%AI	%AQ	Constant
Input 1 (P01)							•	•	•	•†
Input 2 (P02)							•	•	•	•†

† Note that double precision constants are constrained to the range * 32,768 to +32,767.

Programming Example for Not Equal Comparison Function

This example of programming uses the NE function. In this example when input %I0001 is closed (passing power flow to the enable input) the data located in register 240 (parameter P1) is compared to the constant 3650 programmed as parameter P2. If the value in register 240 is not equal to the number 3650 then output %Q0001 will be turned on. For example, if the value in register 240 is * 3650 then output %Q0001 will turn on because this is a signed function and 3650 is not equal to * 3650.

Ladder Diagram Representation

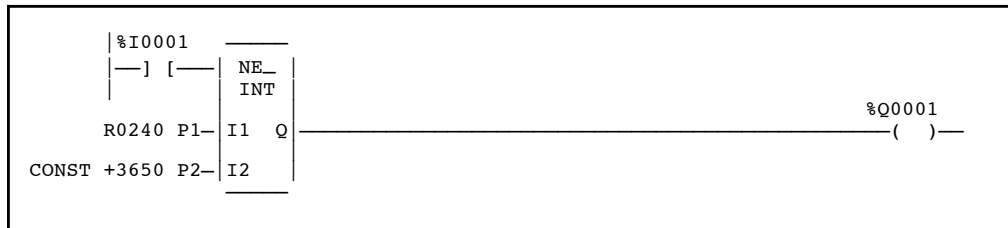

Statement List Representation

```

#0001: LD          %I0001
#0002: FUNC      53  NE
          P1:    %R0240
          P2:    3650
#0003: OUT          %Q0001
    
```

After pressing INS Key: Programming sequence

Key Strokes

HHP Display

Initial display:

```
#0001  INS  <S
_
```

Press the key sequence

LD

A	
—	AI

5 :

```
#0001  INS  <S
  LD      I 1_
```

Press the ENT key:

```
#0002  INS  <S
_
```

Press the key sequence



```
#0002  INS  <S
FUNC 53_  NE
```

Press the  key:

```
#0003  NE  <S
P01  _
```

Press the key sequence



```
#0002  NE  <S
P01  R 240_
```

Press the  key:

```
#0002  NE  <S
P02  _
```

Press the key sequence



```
#0002  NE  <S
P02  3650_
```

Press the  key:

```
#0003  INS  <S
_
```

Press the key sequence

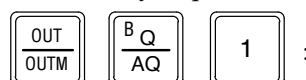

```
#0003  INS  <S
OUT      Q 1_
```

Press the  key:

```
#0004  INS  <S
_
```

Greater Than Comparison (GT) Function 57

Double Precision Greater Than Comparison (DPGT) Function 77

Two greater than test functions are available. The greater than test (GT) is a conditionally executed function which tests for one signed word value greater than another. The double precision greater than test (DPGT) is a conditionally executed function which tests for one signed double word value greater than another.

When the logic controlling the enable input to the function passes power flow to the enable input the function is executed by the CPU and a new signed comparison (for GT) or double precision signed comparison (for DPGT) will take place. During the execution of a greater than comparison the signed value in P1 (input 1) is compared to see if it is greater than the signed value in P2 (input 2). The GT and DPGT functions operate on INT (signed integer) and DINT (double precision signed integer) data respectively. The INT GT function is Function 57 and the DINT GT function is Function 77

GT Function Description

The two values specified by parameters P1 and P2, must be the same data type (16-bit two's complement signed integers) and must be within the range -32768 to $+32767$. This function will pass power flow when there is power flow to the enable input and the value specified by parameter P1 is greater than the value specified by parameter P2.

If discrete memory types are used for parameters P1, and P2 the beginning address must be on a byte boundary.

DPGT Function Description

The two values specified by parameters P1 and P2, must be the same data type (32-bit two's complement signed integers) and must be within the range $-2,147,483,648$ to $+2,147,483,647$. When using the Hand-Held Programmer to program a constant into parameters P1 or P2 the constant must be in the range of a single precision number (-32768 to $+32767$).

The memory locations for P1 and P2 are each 32 Bits long. The storage area for each Register, AI and AQ is 16 Bits long, therefore two consecutive registers, AI words or AQ words must be used for each double precision signed number which is to be stored. The address of the lower of the two registers, AI words, or AQ words is used as the reference to store and retrieve the double precision number.

The Hand-Held Programmer can only display a maximum of 16 bits (one Register, AI, or AQ word) at a time, therefore a double precision number outside of the range -32768 to $+32767$ cannot be programmed into the CPU or monitored using the Hand-Held Programmer. The hexadecimal or binary number for each register AI, or AQ word can be programmed or monitored provided that they are placed together outside of the CPU to form the 32 Bit double precision signed number.

This function will pass power flow when there is power flow to the enable input and the value specified by parameter P1 is greater than the value specified by parameter P2.

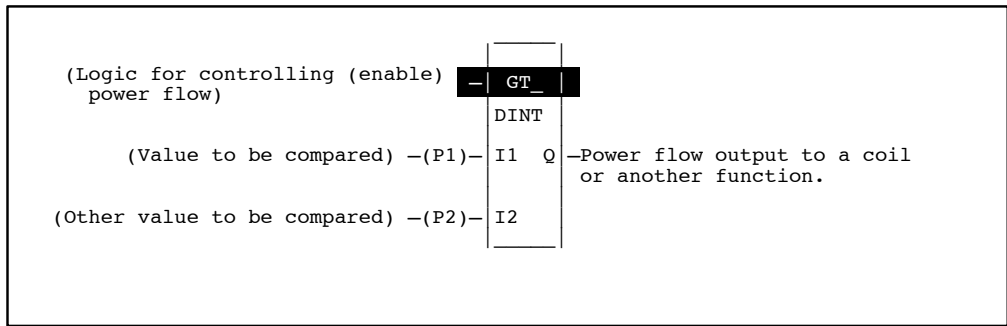

*P1 (Input 1) > P2 (Input 2)

* > means greater than

Programming Elements and Sequential Order of Programming

1. Logic controlling the enable input from the left bus. This must start with an LD element.
2. Type of function, either Function 57 (GT) or Function 77 (DPGT).
3. Parameter P1 (input 1): one of the values to be compared. This can be a constant number or a memory location where the value is stored.
4. Parameter P2 (input 2): the other value to be compared. This can be a constant number or a memory location where the value is stored.

The following tables specify which memory types are valid for each of the GT and DPGT function parameters:

Allowable Memory Types for GT (Function 57)

Parameter	%I	%Q	%M	%T	%G	%S	%R	%AI	%AQ	Constant
I1	•	•	•	•	•		•	•	•	•
I2	•	•	•	•	•		•	•	•	•

Allowable Memory Types for DPGT (Function 77)

Parameter	%I	%Q	%M	%T	%G	%S	%R	%AI	%AQ	Constant
I1							•	•	•	• †
I2							•	•	•	• †

† Note that double precision constants are constrained to the range -32,768 to +32,767.

Programming Example for Greater Than Function

This example of programming uses the GT function. In this example when input %I0001 is closed (passing power flow to the enable input) the data located in register 240 (Parameter P1) is compared to the constant -75 programmed in as parameter P2. If the value in register 240 is greater than -75 then the output %Q0001 will be turned on. For example, if the value in register 240 is 25, which is greater than -75, output %Q0001 will turn on.

Ladder Diagram Representation



Statement List Representation

```

#0001    LD          %I0001
#0002    FUNC      57
           P1:      %R0240
           P2:      -75
#0003    OUT          %Q0001
  
```

After pressing  key: Programming sequence



Keystrokes

HHP Display

Initial display:

```
#0001  INS  <S
```

Press the key sequence

```
#0001  INS  <S
LD      I 1_
```

Press the



```
#0002  INS  <S
```





Press the key sequence

```
#0002  INS  <S
FUNC   57_ GT
```

Press the  key:

```
#0002      GT  <S  
P01  _
```

Press the key sequence
    :

```
#0002      GT  <S  
P01 R    240  _
```

Press the  key:



```
#0002      GT  <S  
P02  _
```

Press the key sequence    :

```
#0002      GT  <S  
P02      -75  _
```

Press the  key:

```
#0003      INS  <S  
_
```

Press the key sequence    :

```
#0003      INS  <S  
OUT      Q  1  _
```

Press the  key:

```
#0004      INS  >S  
_
```

Greater Than or Equal Comparison (GE) Function 55

Double Precision Greater Than or Equal Comparison (DPGE) Function 75

There are two greater than or equal to comparison functions. The greater than or equal to test (GE) is a conditionally executed function which tests for one signed word value greater than or equal to another. The double precision greater than or equal to test (DPGE) is a conditionally executed function which tests for one signed double word value greater than or equal to another.

When the logic controlling the enable input to the function passes power flow to the enable input the function is executed by the CPU and a new signed comparison (for GE) or double precision signed comparison (for DPGE) will take place. During the execution of a signed greater than or equal to comparison or double precision signed greater than or equal to comparison the signed value in P1 (input 1) is compared to see if it is greater than or equal to the signed value in P2 (input 2). The GE and DPGE functions operate on INT (signed integer) and DINT (double precision integer) respectively. The GE function is Function 55 and the DPGE function is Function 75.

GE Function Description

The two values specified by parameters P1 and P2, must be the same data type (16-bit two's complement signed integers) and must be within the range -32768 to $+32767$. This function will pass power flow when there is power flow to the enable input and the value specified by parameter P1 is greater than or equal to the value specified by parameter P2.

If discrete memory types are used for parameters P1, and P2 the beginning address must be on a byte boundary.

DPGE Function Description

The two values specified by parameters P1 and P2, must be the same data type (32-bit two's complement signed integers) and must be within the range $-2,147,483,648$ to $+2,147,483,647$. When using the Hand-Held Programmer to program a constant into parameters P1 or P2 the constant must be in the range of a single precision number (-32768 to $+32767$).

The memory locations for P1 and P2 are each 32 Bits long. The storage area for each Register, AI and AQ is 16 Bits long, therefore two consecutive registers, AI words or AQ words must be used for each double precision signed number to be stored. The address of the lower of the two registers, AI words, or AQ words is used as the reference to store and retrieve the double precision number.

The Hand-Held Programmer can only display a maximum of 16 bits (one Register, AI, or AQ word) at a time, therefore a double precision number outside of the range -32768 to $+32767$ cannot be programmed into the CPU or monitored using the Hand-Held Programmer. The hexadecimal or binary number for each register, AI, or AQ word can be programmed or monitored provided that they are placed together outside of the CPU to form the 32 Bit double precision signed number.

This function will pass power flow when there is power flow to the enable input and the value specified by parameter P1 is greater than or equal to the value specified by parameter P2.

* P1 (Input 1) w P2 (Input 2)

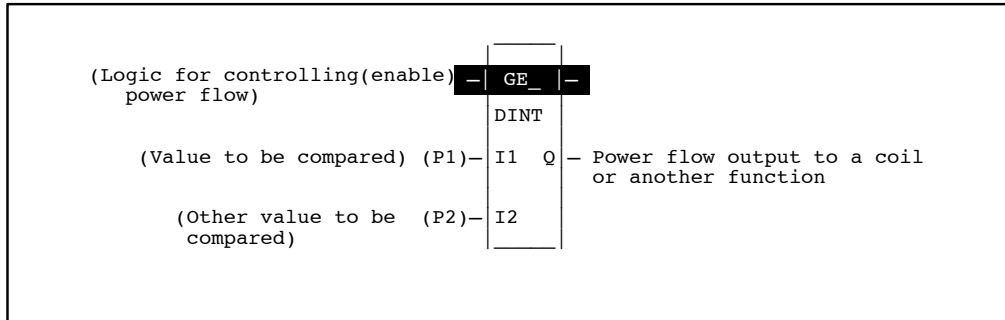

* w means greater than or equal to

Programming Elements and Sequential Order of Programming

1. Logic controlling the enable input from the left bus. This must start with an LD element.
2. Type of function, either Function 55 (GE) or Function 75 (DPGE).
3. Parameter P1 (input 1): one of the values to be compared. This can be a constant number or a memory location where the value is stored.
4. Parameter P2 (input 2): the other value to be compared. This can be a constant number or a memory location where the value is stored.

The following tables specify which memory types are valid for each of the GE and DPGE function parameters:

Allowable Memory Types for GE (Function 55)

Parameter	%I	%Q	%M	%T	%G	%S	%R	%AI	%AQ	Constant
I1 P1	•	•	•	•	•		•	•	•	•
I2 P2	•	•	•	•	•		•	•	•	•

Allowable Memory Types for DPGE (Function 75)

Parameter	%I	%Q	%M	%T	%G	%S	%R	%AI	%AQ	Constant
I1 (P1)							•	•	•	• †
I2 (P2)							•	•	•	• †

† Note that double precision constants are constrained to the range -32,768 to +32,767.

Programming Example for Greater Than or Equal Comparison

This example of programming uses the DPGE function. In this example when input %I0001 is closed (passing power flow to the enable input) the data located in the two memory locations %AI001 and %AI002 (Parameter P1) is compared to the constant 75 programmed as parameter P2. If the combined value in the two memory locations %AI001 and %IA002 is greater than or equal to 75 then the output %Q0001 will be turned on. For example, if the value in memory locations %AI001 is 78, the output %Q0001 will turn on.

Ladder Diagram Representation

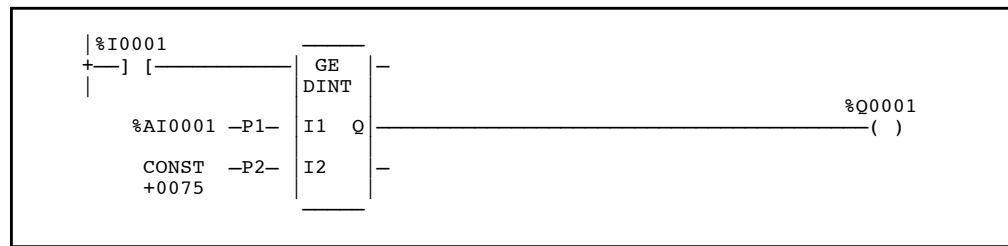

Statement List Representation

```

#0001 LD %I0001
#0002 FUNC 75 DPGE
      P1: %AI001
      P2: 75
#0003 OUT %Q0001
  
```

After pressing **INS** key: Programming sequence

Key Strokes

HHP Display

Initial display:

```
#0001 INS <S
```

Press the key sequence

LD **A1** **1**

```
#0001 INS <S
LD I 1_
```

Press the **ENT** key:

ENT

```
#0002 INS <S
```



Press the key sequence

FUNC **7** **5**

```
#0002 INS <S
FUNC 75 DPGE
```

Press the  key:



#0002	DPGE	<S
P01	_	

Press the key sequence    :

#0002	DPGE	<S
P01	AI	1_

Press the  key:



#0002	DPGE	<S
P02	_	

Press the key sequence   :

#0002	DPGE	<S
P02	75	_

Press the  key:

#0003	INS	<S
_		

Press the key sequence    :

#0003	INS	<S
OUT	Q	1_

Press the  key:

#0004	INS	>S
_		

Less Than Comparison (LT) Function 56

Double Precision Less Than Comparison (DPLT) Function 76

There are two less than comparison functions. The less than test (LT) is a conditionally executed function which tests for one signed word value less than another. The double precision less than test (DPLT) is a conditionally executed function which tests for one signed double word value less than another.

When the logic controlling the enable input to the function passes power flow to the enable input the function is executed by the CPU and a new signed less than comparison (for LT) or double precision signed less than comparison (DPLT) will take place. During the execution of a less than comparison the signed value in P1 (input 1) is compared to determine if it is less than the signed value in P2 (input 2). The LT and DPLT functions operate on INT (signed integer) and DINT (double precision signed integer) data respectively. The INT LT function is Function 56 and the DINT LT function is Function 76.

LT Function Description

The two values specified by parameters P1 and P2, must be the same data type (16-bit two's complement signed integers) and must be within the range -32768 to $+32767$. This function will pass power flow when there is power flow to the enable input and the value specified by parameter P1 is less than the value specified by parameter P2.

If discrete memory types are used for parameters P1, and P2 the beginning address must be on a byte boundary.

DPLT Function Description

The two values specified by parameters P1 and P2, must be the same data type (32-bit two's complement signed integers) and must be within the range $-2,147,483,648$ to $+2,147,483,647$. When using the Hand-Held Programmer to program a constant into parameters P1 or P2 the constant must be in the range of a single precision number (-32768 to $+32767$).

The memory locations for P1 and P2 are each 32 Bits long. The storage area for each register, AI and AQ is 16 Bits long, therefore two consecutive registers, AI words or AQ words must be used for each double precision signed number which is to be stored. The address of the lower of the two registers, AI words, or AQ words is used as the reference to store and retrieve the double precision number.

The Hand-Held Programmer can only display a maximum of 16 bits (one Register, AI, or AQ word) at a time, therefore a double precision number outside of the range -32768 to $+32767$ cannot be programmed into the CPU or monitored using the Hand-Held Programmer. The hexadecimal or binary number for each register, AI, or AQ word may be programmed or monitored provided that they are placed together outside of the CPU to form the 32 Bit double precision signed number.

This function will pass power flow when there is power flow to the enable input and the value specified by parameter P1 is greater than the value specified by parameter P2.

* P1 (Input 1) < P2 (Input 2)

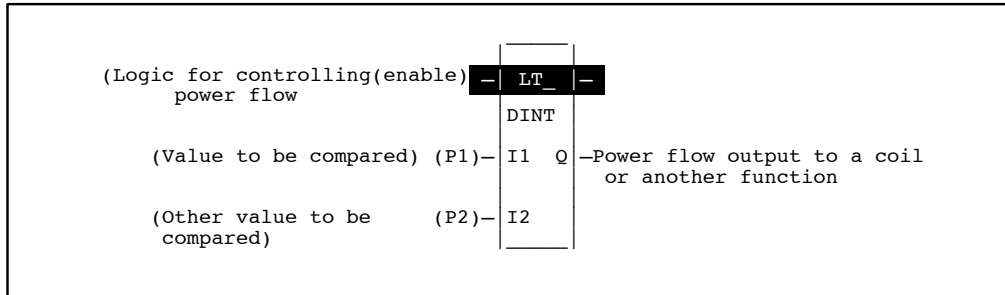

* < means less than

Programming Elements and Sequential Order of Programming

1. Logic controlling the enable input from the left bus. This must start with an LD element.
2. Type of function, either Function 56 (LT) or Function 76 (DPLT).
3. Parameter P1 (input 1): one of the values to be compared. This can be a constant number or a memory location where the value is stored.
4. Parameter P2 (input 2): the other value to be compared. This can be a constant number or a memory location where the value is stored.

The following tables specify which memory types are valid for each of the LT and DPLT function parameters.

Allowable Memory Types for LT (Function 56)

Parameter	%I	%Q	%M	%T	%G	%S	%R	%AI	%AQ	Constant
I1 (P1)	•	•	•	•	•		•	•	•	•
I2 (P2)	•	•	•	•	•		•	•	•	•

Allowable Memory Types for DPLT (Function 76)

Parameter	%I	%Q	%M	%T	%G	%S	%R	%AI	%AQ	Constant
I1 (P1)							•	•	•	• †
I2 (P2)							•	•	•	• †

† Note that double precision constants are constrained to the range -32,768 to +32,767.

Programming Example for LT Function

This example of programming uses the LT function. In this example when input %I0001 is closed (passing power flow to the enable input) the data located in register 240 (Parameter P1) is compared to the constant 38 programmed as parameter P2. If the value in register 240 is less than 38 then the output %Q0001 will be turned on. Assume that the value in register 240 is 38. The output %Q0001 will not turn on because the value in register 38 is equal to the constant 38, and this is a less than function.

Ladder Diagram Representation



Statement List Representation:

#0001	LD		%I0001
#0002	FUNC	56	LT
		P1:	%R0240
		P2:	38
#0003	OUT		%Q0001

After pressing  key:

Key Strokes

HHP Display

Initial display:

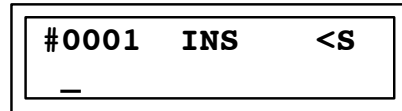

Press the key sequence

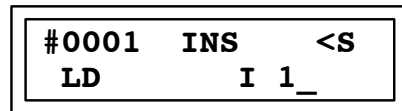
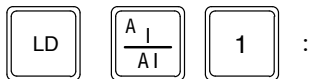

Press the  key:

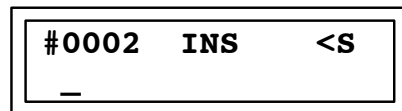

Press the key sequence



```
#0002  INS  <S  
FUNC    56_ LT
```

Press the  key:

```
#0002  LT    <S  
P01    _
```

Press the key sequence

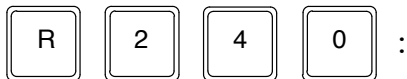

```
#0002  LT    <S  
P01  R 240_
```

Press the  key:

```
#0002  LT    <S  
P02    _
```

Press the key sequence   :

```
#0002  LT    <S  
P02    38_
```

Press the  key:

```
#0003  INS    <S  
_
```

Press the key sequence

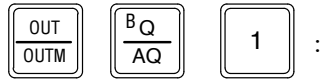

```
#0003  INS    <S  
OUT    Q 1_
```

Press the  key:

```
#0004  INS    <S  
_
```

Less Than or Equal To Comparison (LE) Function 54

Double Precision Less Than or Equal To Comparison (DPLE) Function 74

There are two less than or equal to comparison functions. The less than or equal to test (LE) is a conditionally executed function which tests for one signed word value less than or equal to another. The double precision less than or equal to test (DPLE) is a conditionally executed function which tests for one signed double word value less than or equal to another.

When the logic controlling the enable input to the function passes power flow to the enable input the function is executed by the CPU and a new signed comparison (for LE) or double precision signed comparison (for DPLE) will take place. During the execution the signed value in P1 (input 1) is compared to see if it is less than or equal to the signed value in P2 (input 2). The LE and DPLE functions operate on INT (signed integer) and DINT (double precision signed integer) data respectively. The INT LE function is Function 54 and the DINT LE function is Function 74.

LE Function Description

The two values specified by parameters P1 and P2, must be the same data type (16-bit two's complement signed integers) and must be within the range -32768 to $+32767$. This function will pass power flow when there is power flow to the enable input and the value specified by parameter P1 is less than or equal to the value specified by parameter P2.

If discrete memory types are used for parameters P1 and P2 the beginning address must be on a byte boundary.

DPLE Function Description

The two values specified by parameters P1 and P2, must be the same data type (32-bit two's complement signed integers) and must be within the range $-2,147,483,648$ to $+2,147,483,647$. When using the Hand-Held Programmer to program a constant into parameters P1 or P2 the constant must be in the range of a single precision number (-32768 to $+32767$).

The memory locations for P1 and P2 are each 32 bits long. The storage area for each Register, AI and AQ is 16 bits long, therefore two consecutive registers, AI words or AQ words must be used for each double precision signed number which is to be stored. The address of the lower of the two registers, AI words, or AQ words is used as the reference to store and retrieve the double precision number.

The Hand-Held Programmer can only display a maximum of 16 bits (one Register, AI, or AQ word) at a time, therefore a double precision number outside of the range -32768 to $+32767$ cannot be programmed into the CPU or monitored using the Hand-Held Programmer. The hexadecimal or binary number for each register, AI, or AQ word can be programmed into or monitored provided that they are placed together outside of the CPU to form the 32 bit double precision signed number.

This function will pass power flow when there is power flow to the enable input and the value specified by parameter P1 is less than or equal to the value specified by parameter P2.

* P1 (Input 1) v P2 (Input 2)

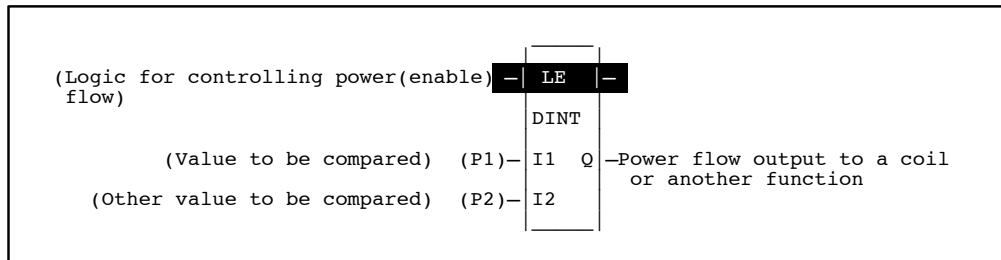

* v means less than or equal to

Programming Elements and Sequential Order of Programming

1. Logic controlling the enable input from the left bus. This must start with an LD element.
2. Type of function, either Function 54 (LE) or Function 74 (DPLE).
3. Parameter P1 (input 1): one of the values to be compared. This can be a constant number or a memory location where the value is stored.
4. Parameter P2 (input 2): the other value to be compared. This can be a constant number or a memory location where the value is stored.

The following tables specify which memory types are valid for each of the LE and DPLE function parameters:

Allowable Memory Types for LE (Function 54)

Parameter	%I	%Q	%M	%T	%G	%S	%R	%AI	%AQ	Constant
I1 P1	•	•	•	•	•		•	•	•	•
I2 P2	•	•	•	•	•		•	•	•	•

Allowable Memory Types for DPLE (Function 74)

Parameter	%I	%Q	%M	%T	%G	%S	%R	%AI	%AQ	Constant
I1 P1							•	•	•	•†
I2 P2							•	•	•	•†

† Note that double precision constants are constrained to the range -32,768 to +32,767.

Programming Example for LE Function

This example of programming uses the LE function. In this example when input %I0001 is closed (passing power flow to the enable input) the data located in register 240 (parameter P1) is compared to the data located in register 280 (parameter P2). If the value in register 240 is less than or equal to the value in register 280 then output %Q0001 will be turned on. Lets say that the value located in register 240 is 860 and the value in register 280 is 2580 then the output %Q0001 will turn on.

Ladder Diagram Representation



Statement List Representation:

```
#0001 LD %I0001
#0002 FUNC 54 LE
      P1: %R0240
      P2: %R0280
#0003 OUT %Q0001
```

After pressing **INS** key:

Key Strokes

HHP Display

Initial display:

```
#0001 INS <S
_
```

Press the key sequence

LD **A I** **1** :

```
#0001 INS <S
LD I 1_
```

Press the **ENT** key:



```
#0002 INS <S
_
```

Press the key sequence

FUNC **5** **4** :

```
#0002 INS <S
FUNC 54_ LE
```

Press the  key:

```
#0002 LE <S
P01 _
```

Press the key sequence

    :

```
#0002 LE <S
P01 R 240_
```

Press the  key:

```
#0002 LE <S
P02 _
```

Press the key sequence



    :

```
#0002 LE <S
P02 R 280_
```

Press the  key:

```
#0003 INS <S
_
```

Press the key sequence

   :

```
#0003 INS <S
OUT Q 1_
```

Press the  key:

```
#0004 INS <S
_
```

Integer Range (RANGI) Function 140

Double Precision Range (RANGDI) Function 141

Word Range (RANGW) Function 142

The RANGE function is used to determine if a value is between the range of two numbers. The RANGE function has four parameters: a Boolean enable (EN), limit 1 (L1), limit 2 (L2), and an input (IN). The RANGE function can operate on either signed integer (INT), double precision signed integer (DINT) or word (WORD) values. The default data type is signed integer; however, it can be changed after selecting the function.

When the logic controlling the enable input (EN) to the function passes power flow, the function is enabled by the CPU, and the RANGE function block will compare the value in input parameter IN (P03) against the range specified by the values in the limit parameters L1 (P01) and L2 (P02). The values specified by L1 and L2 must be the same data type. When the value in IN is within the range specified by L1 and L2, inclusive, output parameter Q is set ON (1). Otherwise, Q is set OFF (0).

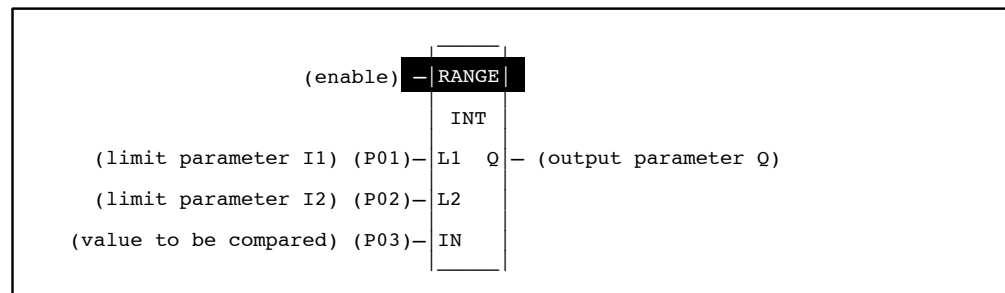

Note

Limit parameters L1 and L2 represent the end points of a range. There are no minimum/maximum or high/low connotation assigned to either parameter. Thus, a desired range of 0 to 100 could be specified by assigning 0 to L1 and 100 to L2 or 0 to L2 and 100 to L1.

Programming Elements and Sequential Order of Programming

1. Logic controlling the enable input from the left bus. This must start with an LD element.
2. Type of function, either Function 140 (RANGI), Function 141 (RANGDI), or Function 142 (RANGW).
3. Parameter P1 (limit 1): one of the limit values. This can be a constant number or a memory location where the value is stored.
4. Parameter P2 (limit 2): the other limit value. This can be a constant number or a memory location where the value is stored.
5. Parameter P3 (input); the value to be compared to the limit values.

The following tables specify which memory types are valid for each of the LE and DPLE function parameters:

Allowable Memory Types for RANGI (Function 140) and RANGW (Function 142)

Parameter	%I	%Q	%M	%T	%G	%S	%R	%AI	%AQ	const
Limit1 (P01)	•	•	•	•	•		•	•	•	•‡
Limit2 (P02)	•	•	•	•	•		•	•	•	•‡
Input (P03)	•	•	•	•	•		•	•	•	

‡ Constants are limited to integer values for double precision signed integer operations.

Allowable Memory Types for RANGDI (Function 141)

Parameter	%I	%Q	%M	%T	%G	%S	%R	%AI	%AQ	const
Limit1 (P01)							•	•	•	•‡
Limit2 (P02)							•	•	•	•‡
Input (P03)							•	•	•	

‡ Constants are limited to integer values for double precision signed integer operations.

Programming Examples for RANGE Function

The following two examples for the RANGE function illustrate how to enter the INT and DINT RANGE instructions using the Hand-Held Programmer.

Example 1:

In the following example, %AI001 is checked to be within a range specified by two constants, 0 and 1000.

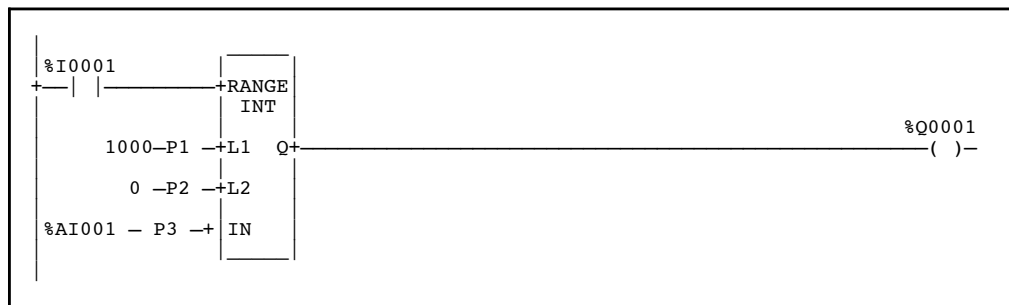

Enable State %I0001	L1 Value Constant	L2 Value Constant	IN Value %AI001	Q State %Q0001
ON	1000	0	< 0	OFF
ON	1000	0	0—1000	ON
ON	1000	0	> 1000	OFF
OFF	1000	0	NotApplicable	OFF

Statement List Representation:

#0001	LD		%I0001
#0002	FUNC	140	RANGI
		P1:	1000
		P2:	0
		P3	%AI0001
#0003	OUT		%Q0001

After pressing  key:



Key Strokes

HHP Display

Initial display:

#0001 INS <S
_

Press the key sequence

  1 :

#0001 INS <S
LD I 1_

Press the  key:

#0002 INS <S
_

Press the key sequence

 1 4 0 :

#0002 INS <S
FUNC 140_RANGI

Press the  key:

#0002 RANGI <S
P01 _

Press the key sequence

    :

#0002 RANGI <S
P01 1000_

Press the  key:

#0002 RANGI <S
P02 _



Press the  key:

```
#0002  RANGI  <S
P02    0
```

Press the  key:

```
#0002  RANGI  <S
P03    _
```

Press the key sequence



   :

```
#0002  RANGI  <S
P03    %AI1
```

Press the  key:

```
#0003  INS    <S
_
```

Press the key sequence

   :

```
#0003  INS    <S
OUT    Q 1_
```

Press the  key:

```
#0004  INS    <S
_
```

Example 2:

In this example, the value of %AI001 is checked to be within a range specified by two register values. For this example, assume that the value in %R0001 is 500 and the value in %R0002 is 0.



RANGE Truth Table				
Enable State %I0001	L1 Value %R0001	L2 Value %R0002	IN Value %AI001	Q State %Q0001
ON	500	0	< 0	OFF
ON	500	0	0 — 500	ON
ON	500	0	> 500	OFF
OFF	500	0	NotApplicable	

Statement List Representation:

```

#0001    LD          %I0001
#0002    FUNC      140  RANGI
          P1:      %R0001
          P2:      %R0002
          P3:      %AI001
#0003    OUT          %Q0001
    
```

After pressing INS key:

Key Strokes

HHP Display

Initial display:

#0001 INS <S
_

Press the key sequence

LD





A	I
—	—
AI	AI

1
:

#0001 INS <S
LD I 1_

Press the  key:



```
#0002  INS  <S
_
```

Press the key sequence     :

```
#0002  INS  <S
FUNC  140_RANGI
```

Press the  key:



```
#0002  RANGI <S
P01  _
```

Press the key sequence   :

```
#0002  RANGI <S
P01  %R1_
```

Press the  key:



```
#0002  RANGI <S
P02  _
```

Press the key sequence   :

```
#0002  RANGI <S
P02  %R2_
```

Press the  key:



```
#0002  RANGI <S
P03  _
```

Press the key sequence    :

```
#0002  RANGI <S
P03  %AI1
```

Press the  key:

```
#0003  INS  <S
_
```

Press the key sequence    :

```
#0003  INS  <S
OUT    Q  1_
```

Press the  key:

```
#0004  INS  <S
_
```

Section 4: Bit Operation Functions

Bit Operation functions perform comparison and movement operations on bit strings which are one or more words in length. Bit Operation functions require word or double word data. The default data type is word. Data types cannot be mixed within the function. Although data must be specified in 16-bit word or 32-bit double word increments, these functions operate on data as a continuous string of bits, with bit 1 of the first word being the Least Significant Bit (LSB). The last bit of the last word is the Most Significant BIT (MSB). For example, if you specified three words of data beginning at reference %R100, it would be operated on as 48 contiguous bits:

%R100	16	15	14	13	12	11	10	9	8	7	6	5	4	3	2	1	← bit 1
%R101	32	31	30	29	28	27	26	25	24	23	22	21	20	19	18	17	
%R102	48	47	46	45	44	43	42	41	40	39	38	37	36	35	34	33	

Caution

Overlapping input and output reference address ranges in multi-word functions may produce unexpected results during program execution.

The following bit operations are described in this section:

Abbreviation	Function	Description
AND	LogicalAND	If a bit in bit string I1 and the corresponding bit in bit string I2 are both 1, place a 1 in the corresponding location in output string Q.
OR	Logical OR	If a bit in bit string I1 and /or the corresponding bit in bit string I2 are both 1, place a 1 in the corresponding location in output string Q.
XOR	Logical Exclusive OR	If a bit in bit string I1 and the corresponding bit in string I2 are different, place a 1 in the corresponding location in the output bit string.
NOT	LogicalInvert	Set the state of each bit in output bit string Q to the opposite state of the corresponding bit in bit string I1.
SHL	Shift Left	Shift all the bits in a word or string of words to the left by a specified number of places.
SHR	Shift Right	Shift all the bits in a word or string of words to the right by a specified number of places.
ROL	Rotate Left	Rotate all the bits in a string a specified number of places to the left.
ROR	RotateRight	Rotate all the bits in a string a specified number of places to the right.
BITSET	Bit Set	Set a bit in a bit string to 1.
BITCLR	Bit Clear	Clear a bit within a string by setting that bit to 0.
BITTST	Bit Test	Test a bit within a bit string to determine whether that bit is currently 1 or 0.
BITPOS	Bit Position	Locate a bit set to 1 in a bit string.
MSKMPW MSKMPD	Masked Compare	Compare the bits in the first string with the corresponding bits in the second.

Bitwise and (AND) Function 23

The bitwise “and” function (AND) is a conditionally executed function which bitwise “ands” one 16-bit word with another.

When the logic controlling the enable input to the function passes power flow to the enable (EN) input the function is executed by the CPU and a new bitwise AND function will take place.

The AND function examines each bit in the memory location specified by P1 (input 1) and the corresponding bit in the memory location specified by P2 (input 2), beginning at the first (lowest addressed) bit in each. For each two bits examined, if both are 1, then a 1 is placed in the corresponding location in the string of bits starting at the location specified by P3 (output Q). If either or both bits is 0, then a 0 is placed in the corresponding location in the string of bits starting at the location specified by P3. The three parameters (P01) input 1, (P02) input 2, and (P03) Q are all 16-bit words.

If discrete memory types are used for parameters P1, P2, and P3 the beginning address must be on an 8 point boundary.

Power flow through this function will follow the conditions of this functions enable input.

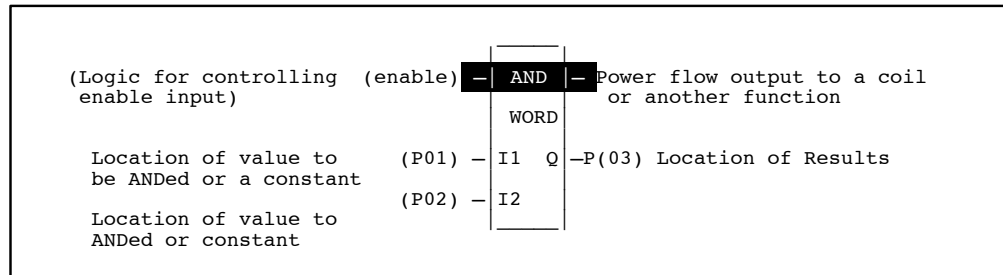

Programming Elements and Sequential Order of Programming

1. Logic controlling the enable input from the left bus. This must start with an LD element.
2. Type of function: Function 23 (AND).
3. Parameter P1 (input 1): one of the values to be ANDed. This can be a constant number or a memory location where the value is stored.
4. Parameter P2 (input 2): the other value to be ANDed. This can be a constant number or a memory location where the value is stored.
5. Parameter P3 (Q). The memory location where the result is to be stored.

The following table specifies which memory types are valid for each of the AND function parameters:

Allowable Memory Types for AND (Function 23)

Parameter	%I	%Q	%M	%T	%G	%S	%R	%AI	%AQ	Constant
Input 1 (P01)	•	•	•	•	•	•	•	•	•	•
Input 2 (P02)	•	•	•	•	•	•	•	•	•	•
Output Q (P03)	•	•	•	•	•	•†	•	•	•	

† Only %SA, %SB, and %SC are used. %S cannot be used.

Programming Example for AND Function

In this example when input %I0001 is closed (passing power flow) to the enable input). The 16 bits of register 1, specified by parameter P1 are bitwise ANDed to the 16 bits of register 2 specified by parameter P(2) and the result is stored in register 3. For example, if the decimal number 337 is stored in %R0001 and decimal number 346 is stored in %R0002, the result will be decimal number 336 stored in %R0003.

The Binary Bits stored in the registers for this example are:

%R0001	0	0	0	0	0	0	0	1	0	1	0	1	0	0	0	1
%R0002	0	0	0	0	0	0	0	1	0	1	0	1	1	0	1	0
%R0003	0	0	0	0	0	0	0	1	0	1	0	1	0	0	0	0

Ladder Diagram Representation

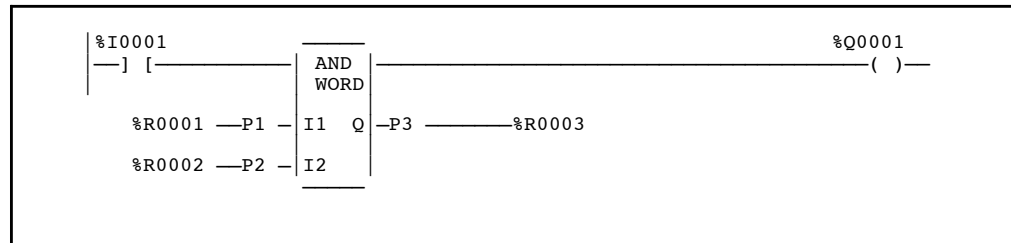

Statement List Representation

#0001	LD		%I0001
#0002	FUNC	23	AND
		P1:	%R0001
		P2:	%R0002
		P3:	%R0003
#0003	OUT		%Q0001

After pressing  key: Programming sequence



Key Strokes

HHP Display

Initial display:

```
#0001  INS  <S  
_
```

Press the key sequence



   :

```
#0001  INS  <S  
LD      I 1_
```

Press the  key:

```
#0002  INS  <S  
_
```

Press the key sequence

   :

```
#0002  INS  <S  
FUNC   23_ AND
```

Press the  key:

```
#0002  AND  <S  
P01  _
```

Press the key sequence

  :

```
#0002  AND  <S  
P01      R 1_
```

Press the  key:

```
#0002  AND  <S  
P02  _
```

Press the key sequence

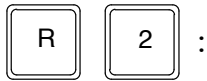

```
#0002  AND  <S  
P02    R 2_
```

Press the  key:

```
#0002  AND  <S  
P03    _
```

Press the key sequence



```
#0002  AND  <S  
P03    R 3_
```

Press the  key:

```
#0003  INS  <S  
_
```

Press the key sequence

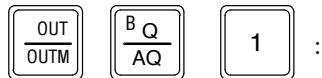

```
#0003  INS  <S  
OUT    Q 1_
```

Press the  key:

```
#0004  INS  <S  
_
```

Bitwise or (OR) Function 25

The bitwise “or” function (OR) is a conditionally executed function which bitwise “or’s” one 16-bit word to another.

When the logic controlling the enable input to the function passes power flow to the enable (EN) input the function is executed by the CPU and a new Bitwise OR function will take place.

Each scan that power flow is received, at the enable input the OR function examines each bit in P1 (Input1) and the corresponding bit in P2 (Input2). Beginning at the first (lowest addressed) bit in each. For each two bits examined, if either or both bits are 1, then a 1 is placed in the corresponding location in bit string Q. The three parameters input (P01) 1, input (P02) 2, and (P03) Q are all 16-bit words.

If discrete memory types are used for parameters P1, P2, and P3 the beginning address must be on a byte boundary.

Power flow through this function will follow the conditions of this functions enable input.

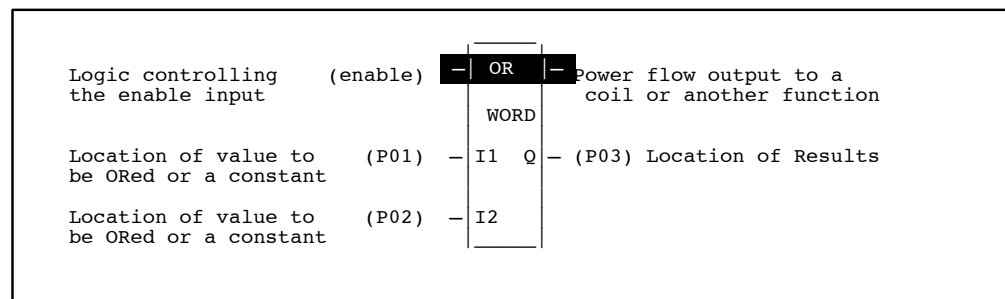

Programming Elements and Sequential Order of Programming

1. Logic controlling the enable input from the left bus. This must start with an LD element.
2. Type of function: Function 25 (OR).
3. Parameter P1 (input 1): one of the values to be ORed. This can be a constant number or a memory location where the value is stored.
4. Parameter P2 (input 2): the other value to be ORed. This can be a constant number or a memory location where the value is stored.
5. Parameter P3 (Q). The memory location where the result is to be stored.

The following table specifies which memory types are valid for each of the OR function parameters:

Allowable Memory Types for OR (Function 25)

Parameter	%I	%Q	%M	%T	%G	%S	%R	%AI	%AQ	Constant
Input 1 (P01)	•	•	•	•	•	•	•	•	•	•
Input 2 (P02)	•	•	•	•	•	•	•	•	•	•
Output Q (P03)	•	•	•	•	•	•†	•	•	•	

† Only %SA, %SB, and %SC are used. %S cannot be used.

Programming Example for OR Function

In this example when input %I0001 is closed (passing power flow to the enable input). The 16 bits of register 1, specified by parameter P1 are bitwise ORed to the 16 bits of register 2, specified by parameter P2 and the result is stored in register 3 as specified by parameter P3. For example, if decimal number 337 is stored in %R0001 and decimal number 346 is stored in %R0002, the result will be decimal number 347 in %R0003.

The binary bits stored in the register are:

%R0001	0	0	0	0	0	0	0	1	0	1	0	1	0	0	0	1
%R0002	0	0	0	0	0	0	0	1	0	1	0	1	1	0	1	0
%R0003	0	0	0	0	0	0	0	1	0	1	0	1	1	0	1	1

Ladder Diagram Representation

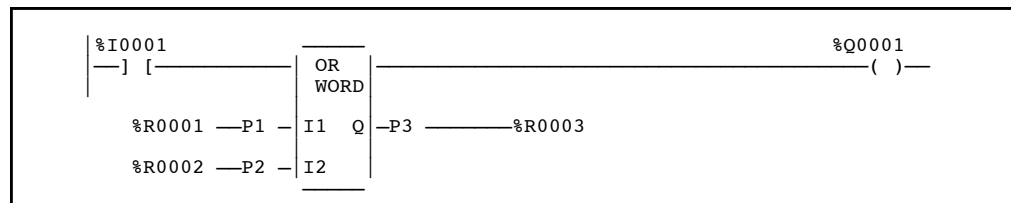

Statement List Representation:

#0001	LD		%I0001
#0002	FUNC	25	OR
		P1:	%R0001
		P2:	%R0002
		P3:	%R0003
#0003	OUT		%Q0001

After pressing  key: Programming sequence



Key Strokes

HHP Display

Initial display:

```
#0001  INS  <S
_
```

Press the key sequence



   :

```
#0001  INS  <S
LD      I 1_
```

Press the  key:

```
#0002  INS  <S
_
```

Press the key sequence

   :

```
#0002  INS  <S
FUNC   25_  OR
```

Press the  key:

```
#0002  OR   <S
P01  _
```

Press the key sequence

  :

```
#0002  OR   <S
P01      R 1_
```

Press the  key:

```
#0002  OR   <S
P02  _
```

Press the key sequence

R **2** :

```
#0002 OR <S  
P02 R 2_
```

Press the **ENT** key:

```
#0002 OR <S  
P03 _
```

Press the key sequence

R **3** :

```
#0002 OR <S  
P03 R 3_
```

Press the **ENT** key:

```
#0003 INS <S  
_
```

Press the key sequence

OUT **B** **1** :
OUTM **AQ**

```
#0003 INS <S  
OUT Q 1_
```

Press the **ENT** key:

```
#0004 INS <S  
_
```

Bitwise Exclusive or (XOR) Function 27

The bitwise “exclusive or” function (XOR) is a conditionally executed function which bitwise “exclusive or’s” one 16-bit word to another.

When the logic controlling the enable input to the function passes power flow to the enable (EN) input the function is executed by the CPU and a new Bitwise XOR Function will take place.

Each scan that power is received, the XOR function examines each bit in P1 (input 1) and the corresponding bit in P2 (input 2) beginning at the first (lowest addressed) bit in each. For each two bits examined, if only one is 1, then a 1 is placed in the corresponding location in the string of bits starting at the location specified by parameter 3 (Q). The three parameters input (P01) 1, input (P02) 2, and output Q (P03) are all 16-bit words.

If input P2 and output P3 begin at the same reference, a 1 placed in the bits specified by P1 will cause the corresponding bit specified by P2 and P3 to alternate between 0 and 1, changing state with each scan as long as power is received. Longer cycles may be programmed by pulsing the power flow to the function at twice the desired rate of flashing. The power flow pulse should be one scan long (one-shot type coil, or self-resetting timer).

If discrete memory types are used for parameters P1, P2, and P3 the beginning address must be on a byte boundary.

Power flow through this function will follow the condition of this functions enable input.

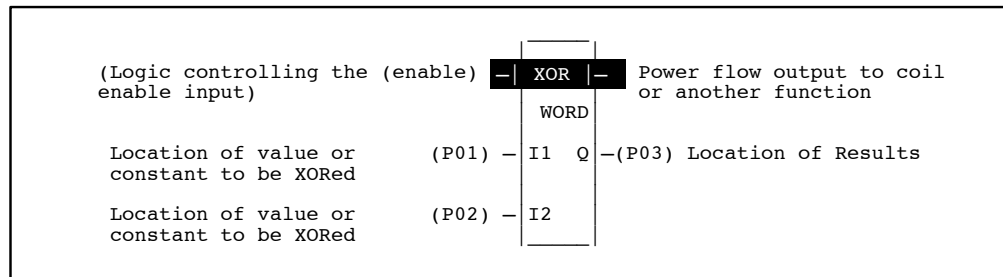

Programming Elements and Sequential Order of Programming

1. Logic controlling the enable input from the left bus. This must start with an LD element.
2. Type of function: Function 27 (XOR).
3. Parameter P1 (input 1): one of the values to be XORed. This can be a constant number or a memory location where the value is stored.
4. Parameter P2 (input 2): the other value to be XORed. This can be a constant number or a memory location where the value is stored.
5. Parameter P3 (Q). The memory location where the result is to be stored.

The following table specifies which memory types are valid for each of the XOR function parameters:

Allowable Memory Types for XOR (Function 27)

Parameter	%I	%Q	%M	%T	%G	%S	%R	%AI	%AQ	Constant
Input 1 (P01)	•	•	•	•	•	•	•	•	•	•
Input 2 (P02)	•	•	•	•	•	•	•	•	•	•
Output Q (P03)	•	•	•	•	•	•†	•	•	•	

† Only %SA, %SB, and %SC are used. %S cannot be used.

Programming Example for XOR Function

In this example when input %I0001 is closed (passing power flow to the enable input). The 16 bits of register %R0140, specified by parameter P1 are bitwise XORed to the 16 bits of register %R0141 specified by parameter P2. The result is stored in Register %R0281 specified by parameter P3. For example, if register R0140 has the decimal number 8136 in it and register %R0141 has the decimal number -8137 in it. The result in Register R0281 is the decimal number -1.

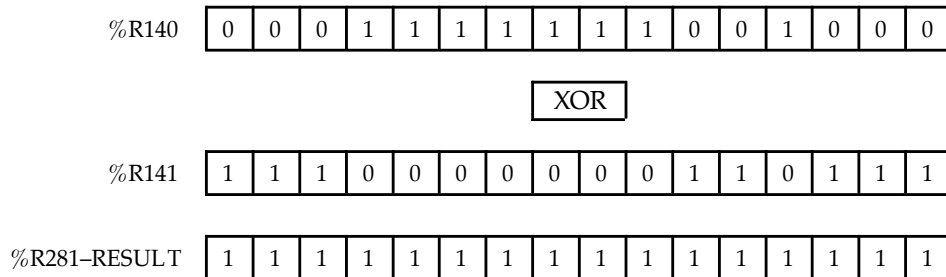

Ladder Diagram Representation

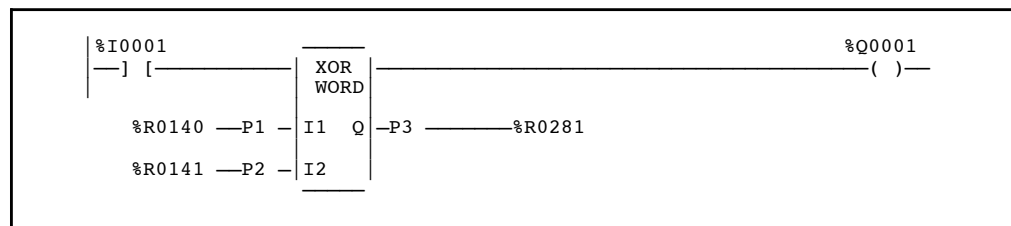

Statement List Representation:

#0001	LD		%I0001
#0002	FUNC	27	XOR
		P1:	%R0140
		P2:	%R0141
		P3:	%R0281
#0003	OUT		%Q0001



After pressing  key: Programming sequence

Key Strokes HHP Display

Initial display:

```
#0001  INS  <S  
_
```

Press the key sequence



   :

```
#0001  INS  <S  
LD      I 1_
```

Press the  key:

```
#0002  INS  <S  
_
```

Press the key sequence

   :

```
#0002  INS  <S  
FUNC  27_ XOR
```

Press the  key:

```
#0002  XOR  <S  
P01  _
```

Press the key sequence

    :

```
#0002  XOR  <S  
P01      R 140_
```

Press the  key:

```
#0002  XOR  <S  
P02  _
```

Press the key sequence

R **1** **4** **1** :

```
#0002 XOR <S  
P02 R 141_
```

Press the **ENT** key:

```
#0002 XOR <S  
P03 _
```

Press the key sequence

R **2** **8** **1** :

```
#0002 XOR <S  
P03 R 281_
```

Press the **ENT** key:

```
#0003 INS <S  
_
```

Press the key sequence

OUT **BQ** **1** :
OUTM **AQ**

```
#0003 INS <S  
OUT Q 1_
```

Press the **ENT** key:

```
#0004 INS <S  
_
```

Bitwise NOT (NOT) Function 29

The bitwise one's complement function (NOT) is a conditionally executed function which bitwise negates (one's complements) a 16-bit word.

When the logic controlling the enable input to the function passes power flow to the enable (EN) input the function is executed by the CPU and a new NOT function will take place.

All bits in P1 (input 1) are altered when power flow is received, making output P2 (Q) a mirror image of the bits specified by P1 (input 1). The two parameters input (P01) 1 and output (P02) Q are both 16-bit words.

If discrete memory types are used for parameters P1, and P2 the beginning address must be on a byte boundary.

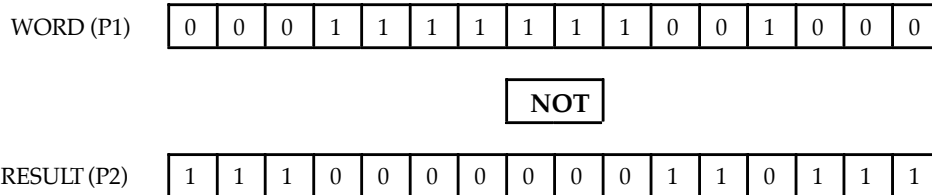
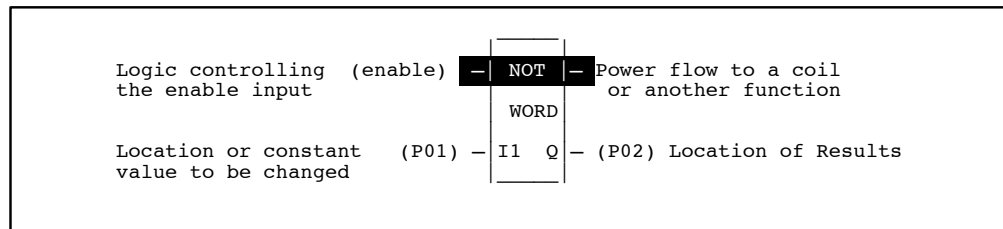

Programming Elements and Sequential Order of Programming

1. Logic controlling the enable input from the left bus. This must start with an LD element.
2. Type of function: Function 29 (NOT).
3. Parameter P1 (input 1): the values to be NOTed. This can be a constant number or a memory location where the value is stored.
4. Parameter P2 (Q): the memory location where the result of the NOT operation is to be stored.

The following table specifies which memory types are valid for each of the NOT function parameters:

Allowable Memory Types for NOT (Function 29)

Parameter	%I	%Q	%M	%T	%G	%S	%R	%AI	%AQ	Constant
Input 1 (P01)	•	•	•	•	•	•	•	•	•	•
Output Q (P02)	•	•	•	•	•	•†	•	•	•	

† Only %SA, %SB, and %SC are used. %S cannot be used.

Programming Example for NOT Function

For example, if in this example when input %I0001 is closed (passing power flow to the enable input). The 16 bits of register 250, specified by parameter P1 are altered. (1's becomes 0's and 0's becomes 1's) and are stored in register 251. R1 contains decimal number 8136 then R2 will contain the decimal number -8137 or the result.

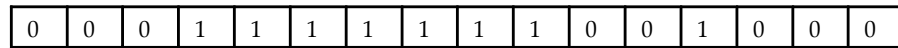

NOT

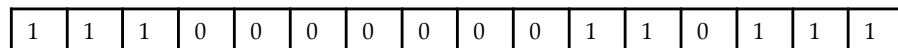

Ladder Diagram Representation

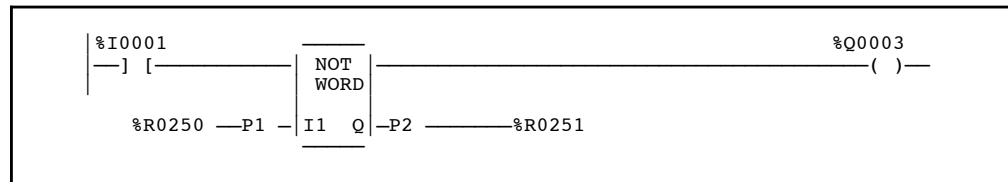

Statement List Representation

#0001	LD		%I0001
#0002	FUNC	29	NOT
		P1:	%R0250
		P2:	%R0251
#0003	OUT		%Q0003

After pressing INS key: Programming sequence

Key Strokes

HHP Display

Initial display:

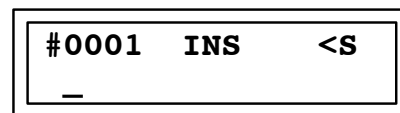

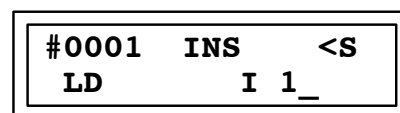
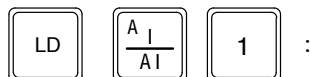

Press the key sequence



Press the  key:

```
#0002  INS  <S
_
```

Press the key sequence

   :

```
#0002  INS  <S
FUNC  29_ NOT
```

Press the  key:

```
#0002  NOT  <S
P01  _
```

Press the key sequence

    :

```
#0002  NOT  <S
P01      R 250_
```

Press the  key:

```
#0002  NOT  <S
P02  _
```

Press the key sequence



    :

```
#0002  NOT  <S
P02      R 251_
```

Press the  key:

```
#0002  XOR  <S
_
```

Press the key sequence

   :

```
#0002  INS  <S
OUT      Q 3_
```

Bit Shift Left (SHL) Function 30

The bit shift left function (SHL) is a conditionally executed function which shifts all bits in a word array left a given number of bit positions.

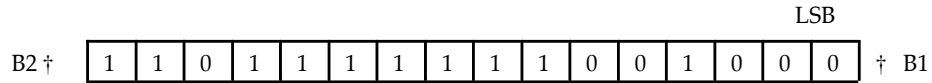

When the logic controlling the enable input to the function passes power flow to the enable (EN) input the function is executed by the CPU. During the execution of a shift left function all of the bits in a word or a group of consecutive 16 bit words connected together to form a continuous string of bits are shifted left a specified number of bit locations.

The location of the word or group of words is specified by parameter P1 which is the memory address location for the first word of the group of consecutive words containing the group of bits to be shifted.

The number of 16 bit words in the consecutive group of words forming the continuous string bits is specified by parameter P3 (LEN). The limits of LEN depend on the memory type being used and the starting address of the first word of the group of words containing the bits to be shifted, and the starting address of the final memory location where the shifted bits are to be stored. If the length plus the memory address exceeds the total number of words for that memory type DATA ERR will be displayed on the screen of the Hand-Held Programmer.

The number of bit locations that each bit is shifted each time this function is executed is specified by parameter P2 (N). The number of location specified by N must be more than zero and less than the total number of bits in the group of consecutive words.

When the shift occurs a number of bits specified by N will be shifted out of the left end (highest bit location) of the last word of the group of bits. The last bit shifted out of the group will determine the condition of B2 (see note below) which is power flow through this function. A zero shifted out will be no power flow, and a one shifted out will give power flow.

Also the same number of bits are shifted into the vacant locations located at the right end (lowest bit location) of the group of bits. The state of the bits being shifted into the vacant locations is specified by the condition of the logic programmed into the B1 input. Power flow from the left bus to the B1 input will enter a one. No power flow to the B1 input will enter a zero into the group of vacant bit locations. If a length (N parameter P2) greater than one has been specified as the number of bits to be shifted, each of the vacant locations will be filled with the same value (0 or 1).

If the number of bits to be shifted (N) is greater than the number of bits in the array (LEN) * 16, then the array (Q) is filled with copies of the input bit (B1), and the input bit is copied to the output power flow (B2). If the number of bits to be shifted is zero, then no shifting is performed; the output array is untouched; and power flow is OFF.

The result of the shifted operation is stored in the location of the word or group of consecutive words specified by parameter P4 (Q) which is the memory address location for the first word of the group of consecutive words containing the string of bits that has been shifted.

Parameters P1 and P4 are memory locations representing 16 bit words, and parameters P2 and P3 are constants, while B1 input is the result of some logic attached to this functions B1 input. If discrete memory types are used for parameters P1, P2, and P4 the beginning address must be on an 8 point boundary.

Power flow through this function occurs only when the functions enable input is receiving power flow and the last bit shifted out is a one.

Note

The B2 output is used with Logicmaster 90 programming software as a connection point for connecting another function or coil to the power flow condition of this function.

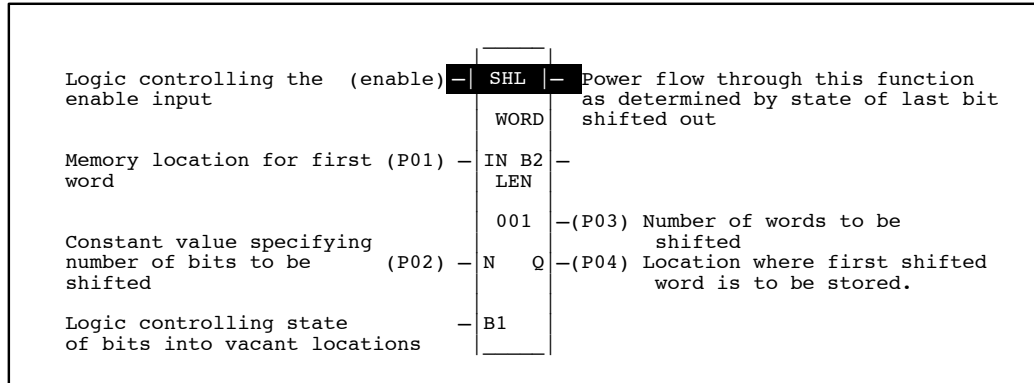

Programming Elements and Sequential Order of Programming

1. Logic controlling the enable input from the left bus. This must start with an LD element.
2. Logic from the left bus controlling the state of input B1. This logic must start with an LD element.
3. Type of function: Function 30 (SHL).
4. Parameter P1 (IN): the memory address location for the first word of the group of words containing the bits to be shifted.
5. Parameter P2 (N): a constant specifying the number of bits to be shifted each time a shift takes place.
6. Parameter P3: a constant specifying the number of words (each word is 16 bits long) that will be connected together to form the total number of bits in the group.
7. Parameter P4 (Q): the memory address location where the first word of the group of words containing the results of the bits that have been shifted is to be stored.

The following table specifies which memory types are valid for each of the SHL function parameters:

Allowable Memory Types for SHL (Function 30)

Parameter	%I	%Q	%M	%T	%G	%S	%R	%AI	%AQ	Constant
Input IN (P01)	•	•	•	•	•	•	•	•	•	
Distance N (P02)	•	•	•	•	•		•	•	•	•
Length LEN (P03)										•
Output Q (P04)	•	•	•	•	•	•†	•	•	•	

† Only %SA, %SB, and %SC are used. %S cannot be used.

Programming Example for SHL Function

In the following example a contact from a one shot (OUT+) is used as the controlling element for power flow to the enable function. When input %I0001 closes (passes power flow), %M0001 will pass power flow to the enable input of the SHL function for one sweep of the CPU scan.

The 32 bits of two consecutive 16-Bit words starting at Register 1 and ending with Register 2 (note that the length P3 is 2). The two 16-bit words will shift left one bit space (N (P2)=1). The result will be placed into the two consecutive 16-bit words starting at R10.

The first bit of Register 10 will have the same state as %I0002, the logic controlling the power flow to B1 input. For example, if B1 is passing powerflow giving an on condition for a state of 1 and Registers 1 and 2 have the bit pattern as shown below, then Registers 10 and 11 be as shown below. The last bit shifted out of Register 2 was a one, therefore this function will pass powerflow.

Ladder Diagram Representation

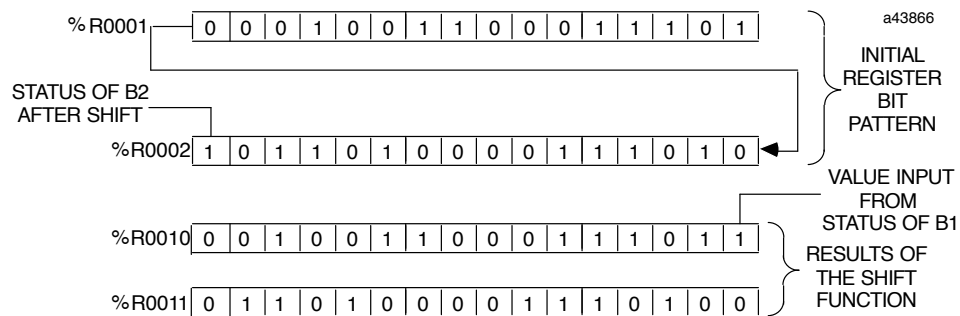
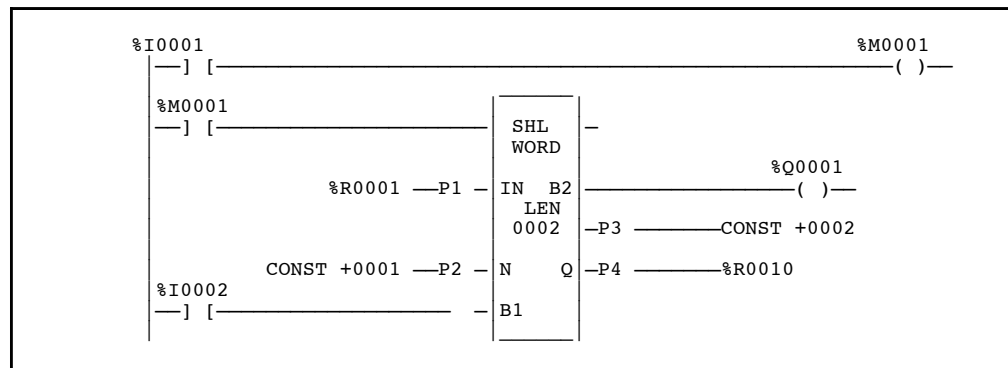

Statement List Representation

```

#0001    LD          %I0001
#0002    OUT+       %M0001
#0003    LD          %M0001
#0004:   LD          %I0002
#0005:   FUNC 30    SHL
                        P1:  %R0001
                        P2:  0001
                        P3:  0002
                        P4:  %R0010
#0006:   OUT          %Q0001
    
```

After pressing  key: Programming sequence



Key Strokes

HHP Display

Initial display:

```
#0001  INS  <S
_
```

Press the key sequence



   :

```
#0001  INS  <S
LD      I 1_
```

Press the  key:

```
#0002  INS  <S
_
```

Press the key sequence

   :

```
#0002  INS  <S
OUT+   M 1_
```

Press the  key:

```
#0003  INS  <S
_
```

Press the key sequence



   :

```
#0003  INS  <S
LD      M 1_
```

Press the  key:

```
#0004  INS  <S
_
```

Press the key sequence



   :

```
#0004  INS  <S
LD      I2
```

Press the  key:

```
#0005  INS  <S  
_
```

Press the key sequence

   :

```
#0005  INS  <S  
FUNC  30_  SHL
```

Press the  key:

```
#0005  SHL  <S  
P01  _
```

Press the key sequence

  :

```
#0005  SHL  <S  
P01   R 1_
```

Press the  key:

```
#0005  SHL  <S  
P02  _
```

Press the key sequence  :

```
#0005  SHL  <S  
P02           1_
```

Press the  key:

```
#0005  SHL  <S  
P03  _
```



Press the key sequence  :

```
#0005  SHL  <S  
P03           2_
```

Press the  key:

```
#0005 SHL <S  
P04 _
```

Press the key sequence



   :

```
#0005 SHL <S  
P04 R10_
```

Press the  key:

```
#0006 INS <S  
_
```

Press the key sequence

   :

```
#0006 INS <S  
OUT Q 1_
```

Press the  key:

```
#0007 INS <S  
_
```

Bit Shift Right (SHR) Function 31

The bit shift right function (SHR) is a conditionally executed function which shifts all bits in a word array right a given number of bit positions.

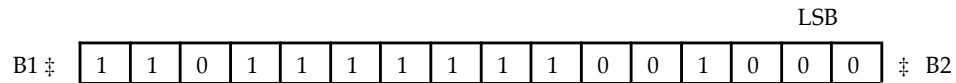

When the logic controlling the enable input to the function passes power flow to the enable (EN) input the function is executed by the CPU. During the execution of a shift right function all of the bits in a word or a group of consecutive 16 bit words connected together to form a continuous string of bits are shifted to the right a specified number of memory bit locations.

The location of the word or group of words is specified by parameter P1 which is the memory address location for the first word of the group of consecutive words containing the group of bits to be shifted.

The number of 16 bit words in the consecutive group of words forming the continuous string of bits is specified by parameter P3 (LEN). The limits of LEN depend on the memory type being used and the starting address of the first word of the group of words containing the bits to be shifted, and the starting address of the final memory location where the shifted bits are to be stored. If the length plus the memory address exceed the total number of words for that memory type DATA ERR will be displayed on the screen of the Hand-Held Programmer.

The number of bit locations that each bit is shifted each time this function is executed is specified by parameter P2 (N). The number of locations specified by N must be more than zero and less than the total number of bits in the group of consecutive words specified in the LEN parameter.

When the shift occurs the number of bits specified by N will be shifted out of the right end (lowest bit location) of the first word of the group of bits. The last bit shifted out of the group will determine the condition of B2 (see the note below) which determines power flow through this function. A zero shifted out will result in no power flow, and a one shifted out will give power flow.

If the number of bits to be shifted (N) is greater than the number of bits in the array (LEN) * 16, then the array (Q) is filled with copies of the input bit (B1), and the input bit is copied to the output power flow (B2). If the number of bits to be shifted is zero, then no shifting is performed; the output array is untouched; and power flow is OFF.

Also the same number of bits are shifted into the vacant locations located at the left end (highest bit location) of the group of bits. The state of the bits being shifted into the vacant locations is specified by the condition of the logic programmed into the B1 input. Power flow from the left bus to the B1 input will enter a one. No power flow to the B1 input will enter a zero into the group of vacant bit locations. If a length (N parameter P2) greater than one has been specified as the number of bits to be shifted, each of the vacant locations will be filled with the same value (0 or 1).

The results of the shifted operation are stored in the location of the word or group of consecutive words specified by parameter P4 (Q) which is the memory address location for the first word of the group of consecutive words containing the group of bits that has been shifted.

Parameters P1 and P4 are memory locations representing 16 bit words, and parameters P2 and P3 are constants, while B1 input is the results of some logic attached to this functions B1 input.

If discrete memory types are used for parameters P1, P2, and P4 the beginning address must be on an 8 point boundary.

Power flow through this function occurs only when the functions enable input is receiving power flow and the last bit shifted out is a one.

Note

B2 is used with Logicmaster 90 as a connection point for connecting another function or coil to the power flow condition of this function.

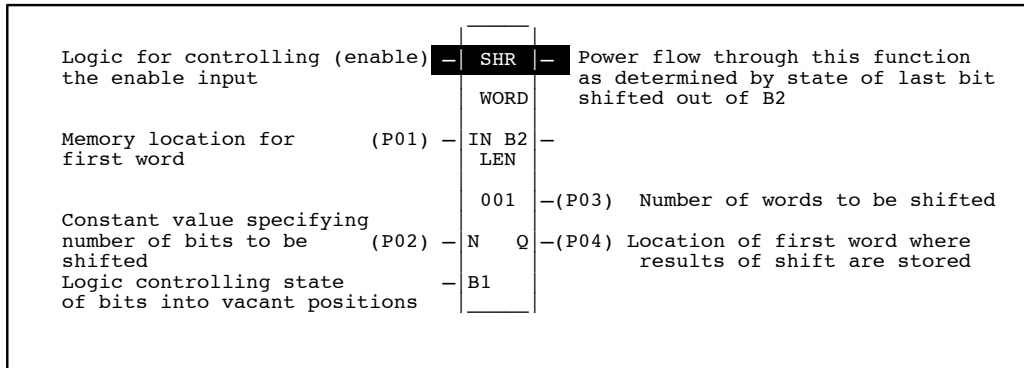

Programming Elements and Sequential Order of Programming

1. Logic controlling the enable input from the left bus. This must start with an LD element.
2. Logic from the left bus controlling the state of input B1. This logic must start with an LD element.
3. Type of function: Function 31 (SHR).
4. Parameter P1 (IN): the memory address location for the first word of the group of words containing the bits to be shifted.
5. Parameter P2 (N): a constant specifying the number of bits to be shifted each time a shift takes place.
6. Parameter P3: a constant specifying the number of words (each word is 16 bits long) that will be connected together to form the total number of bits in the group.
7. Parameter P4 (Q): the memory address location where the first word of the group of words containing the results of the bits that have been shifted is to be stored.

The following table specifies which memory types are valid for each of the SHR function parameters:

Allowable Memory Types for SHR (Function 31)

Parameter	%I	%Q	%M	%T	%G	%S	%R	%AI	%AQ	Constant
Input IN (P01)	•	•	•	•	•	•	•	•	•	
Distance N (P02)	•	•	•	•	•		•	•	•	•
Length LEN (P03)										•
Output Q (P04)	•	•	•	•	•	•†	•	•	•	

† Only %SA, %SB, and %SC are used. %S cannot be used.

Programming Example for SHR Function

In the following example a contact from a one shot (out) is used as the controlling element for powerflow to the enable function. When input one closes (passes power flow), %M0001 will pass powerflow to the enable input of the SHR function for one sweep of the CPU scan.

The 32 bits of the two consecutive 16-bit words start at Register 10 and end with Register 11 (note that the length P3 is 2). These two 16-bit words will shift right one bit space (N (P2)=1). The result will be placed into two consecutive 16 bits words starting at R20.

The last bit of Register 11 will have the same state as the logic controlling the powerflow to B1. Lets say that B1 is passing powerflow giving an on condition for a state of 1 and Registers 10 and 11 have the bit pattern shown below then Registers 20 and 21 will have the bit pattern as shown. The last bit shifted out of Register 10 was a one therefore this function will pass powerflow.

Ladder Diagram Representation

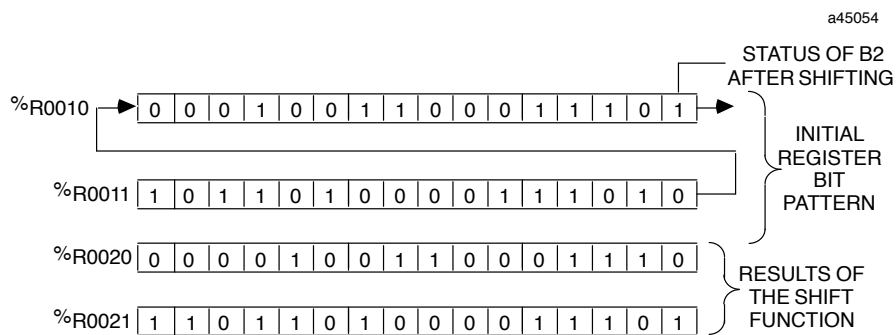
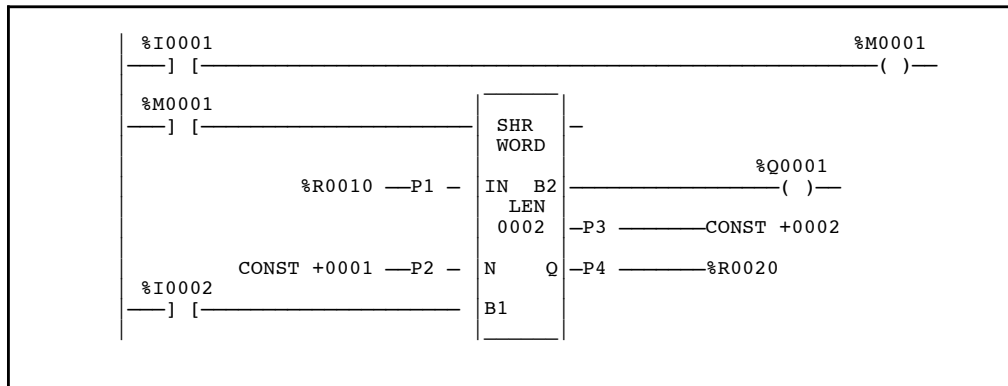

Statement List Representation

#0001:	LD		%I0001
#0002:	OUT+		%M0001
#0003:	LD		%M0001
#0004:	LD		%I0002
#0005:	FUNC	31	SHR
		P1:	%R0010
		P2:	%0001
		P3:	%0002
		P4:	%R0020
#0006:	OUT		%Q0001

After pressing  key: Programming sequence



Key Strokes

HHP Display

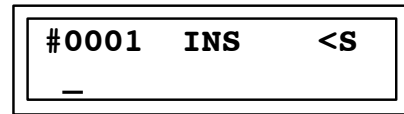
Initial display:



Press the key sequence

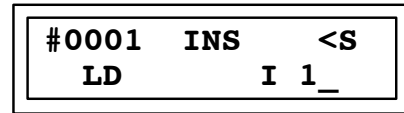

   :

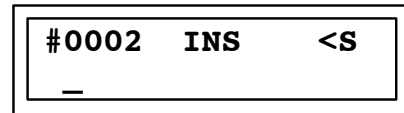

Press the  key:



Press the key sequence

   :

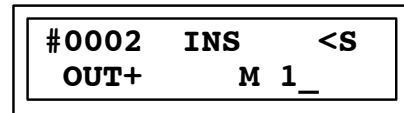

Press the  key:

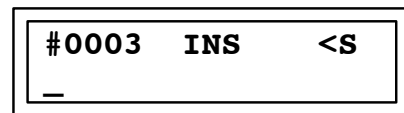

Press the key sequence

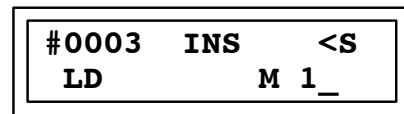

   :



Press the  key:

```
#0004  INS  <S  
_
```

Press the key sequence



   :

```
#0004  INS  <S  
LD      I2
```

Press the  key:

```
#0005  INS  <S  
_
```

Press the key sequence

   :

```
#0005  INS  <S  
FUNC   31_  SHR
```

Press the  key:

```
#0005  SHR  <S  
P01  _
```

Press the key sequence

   :

```
#0005  SHR  <S  
P01   R 10_
```

Press the  key:

```
#0005  SHR  <S  
P02  _
```

Press the key sequence  :

```
#0005  SHR  <S  
P02   1_
```

Press the  key:

```
#0005  SHR  <S  
P03  _
```

Press the key sequence 2 :

```
#0005 SHR <S
P03 2_
```

Press the ENT
↓ key:

```
#0005 SHR <S
P04 _
```

Press the key sequence R 2 0 :

```
#0005 SHR <S
P04 R 20_
```

Press the ENT
↓ key:

```
#0005 INS <S
_
```

Press the key sequence OUT
OUTM BQ
AQ 1 :

```
#0006 INS <S
OUT Q 1_
```

Press the ENT
↓ key:

```
#0007 INS <S
_
```

Bit Rotate Left (ROL) Function 32

The bit rotate left function (ROL) is a conditionally executed function which rotates all bits in a word array left a given number of bit positions.

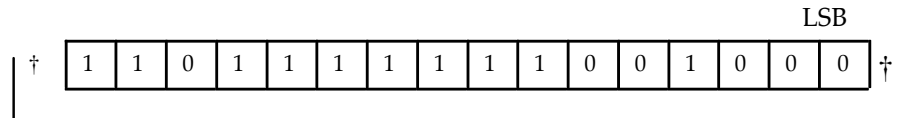

When the logic controlling the enable input to the function passes power flow to the enable (EN) input the function is executed by the CPU. During the execution all of the bits in a word or a group of consecutive 16 bit words connected together to form a continuous string of bits are shifted left a specified number of memory bit locations. The bits which are shifted out of the left end (highest bit location) of the group of bits are shifted into the vacant locations at the right end (lowest bit location) of the group of bits.

The location of the word or group of words is specified by parameter P1 which is the memory address location for the first word of the group of consecutive words containing the group of bits to be rotated.

The number of 16 bit words in the consecutive group of words forming the continuous string of bits is specified by parameter P3 (LEN). The limits of LEN depend on the memory type being used and the starting address of the first word of the group of words containing the bits to be shifted, and the starting address of the final memory location where the shifted bits are to be stored. If the length plus the memory address exceed the total number of words for that memory type DATA ERR will be displayed on the screen of the Hand-Held Programmer.

The number of bit locations that each bit is shifted each time this function is executed is specified by parameter P2 (N). The number of locations specified by N must be more than zero and less than the total number of bits in the group of consecutive words.

When the shift occurs a number of bits specified by N will be shifted out of the left end (highest bit location) of the last word of the group of bits. These bits are shifted into the vacant locations created by the shift which is located at the right end (lowest bit location) of the group of bits.

If the number of bits to rotate (N) is greater than the specified length of the array (LEN) in bits and there is power flow into the ROL function, then the entire output array will be set equal to the input array and power flow out of ROL will be off. If power flow into ROL is ON and no error is detected, then power flow out of ROL is on.

The results of the shifted operation are stored in the location of the word or group of consecutive words specified by parameter P4 (Q) which is the memory address location for the first word of the group of consecutive words containing the string of bits that has been shifted.

Parameters P1, P2, and P4 are 16 bit word memory locations representing 16 bit words, and parameter P3 is a constant. If discrete memory types are used for parameters P1, P2, and P4, the beginning address must be on an 8-point boundary.

Power flow through this function occurs only when the functions enable input is receiving power flow. To prevent multiple rotations from taking place it is advisable to have the power flow to the enable input be controlled by a contact of a one shot element (OUT+ or OUT-).

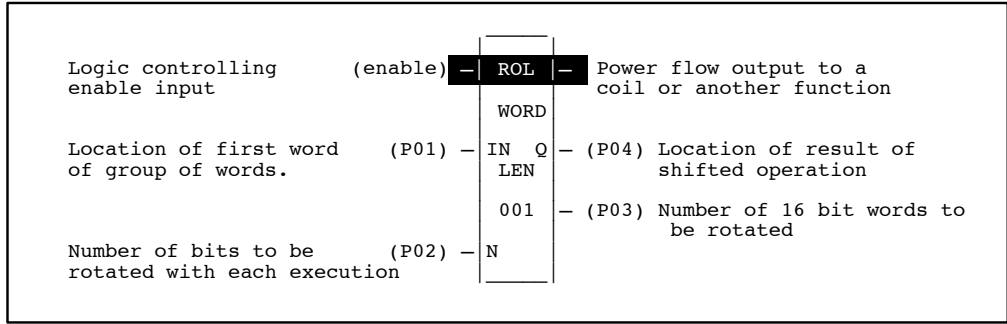

Programming Elements and Sequential Order of Programming

1. Logic controlling the enable input from the left bus. This must start with an LD element.
2. Type of function: Function 32 (ROL).
3. Parameter P1 (IN): the memory address location for the first word of the group of words containing the bits to be rotated.
4. Parameter P2 (N): number of bits to be rotated each time a shift takes place. This can be a constant value or a memory location where the value is stored.
5. Parameter P3: a constant specifying the number of words (each word is 16 bits long) that will be connected together to form the total number of bits in the group.
6. parameter P4 (Q): the memory address location where the first word of the group of words containing the results of the bits that have been rotated is to be stored.

The following table specifies which memory types are valid for each of the ROL function parameters:

Allowable Memory Types for ROL (Function 32)

Parameter	%I	%Q	%M	%T	%G	%S	%R	%AI	%AQ	Constant
Input IN (P01)	•	•	•	•	•	•	•	•	•	
Distance N (P02)	•	•	•	•	•		•	•	•	•
Length LEN (P03)										•
Output Q (P04)	•	•	•	•	•	•†	•	•	•	

† Only %SA, %SB, and %SC are used. %S cannot be used.

Programming Example for ROL Function

In the following example a contact for a one shot (OUT+) is used as the controlling element for power flow to the enable function. Thus when input one closes (passes power flow), %M0001 will pass power flow to the input of the ROL function for one sweep of the CPU scan. Therefore ROL will occur only once. When the ROL function takes place the 48 bits of registers %R0030, %R0031 and %R0032 specified by parameter P1 will rotate left two bit spaces (N(P2)= 2). The result will be placed into the 16-bit words of registers %R0002, %R0003 and %R0004 specified by parameter P4. Parameter P2 is a constant of 2 specifying the number of bits to be rotated (shifted) each time a rotate is executed. P3 specifies the number of words to be connected together to form the total number of bits in the word.

Before Rotate Left:

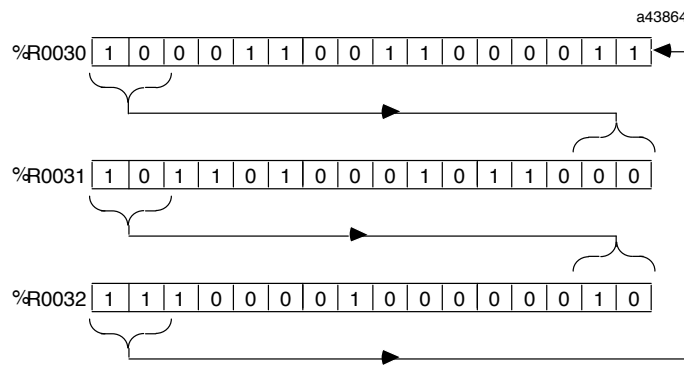

After Rotate Left:

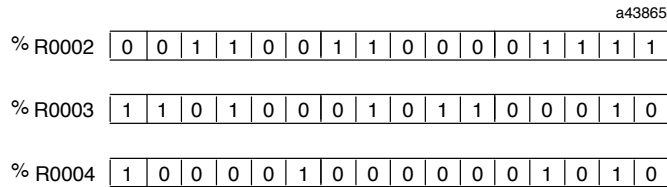

Ladder Diagram Representation

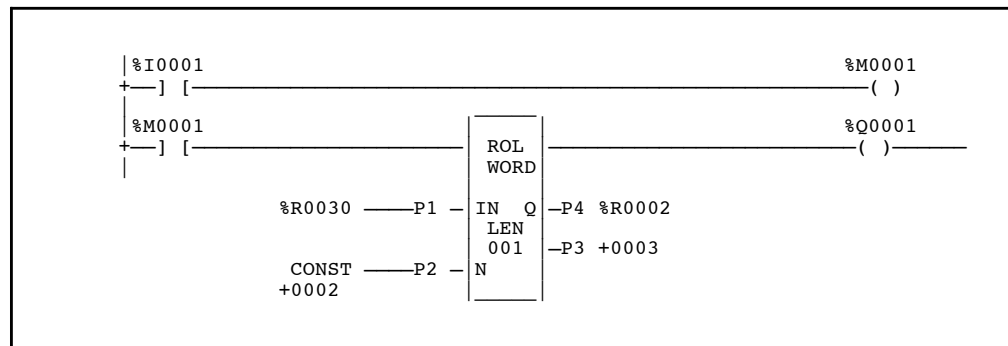

Statement List Representation

#0001:	LD		%I0001
#0002:	OUT+		%M0001
#0003:	LD		%M0001
#0004:	FUNC	32	ROL
		P1:	%R0030
		P2:	+0002
		P3:	+0003
		P4:	%R0002
#0005:	OUT		%Q0001

After pressing  key: Programming sequence

Key Strokes

HHP Display

Initial display:

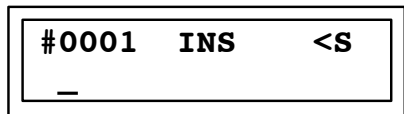

Press the key sequence

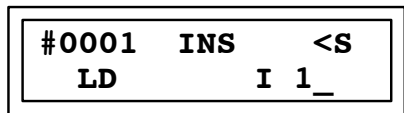
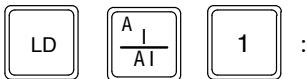

Press the  key:

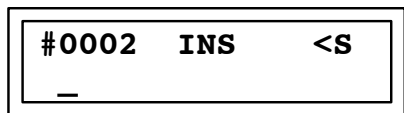

Press the key sequence

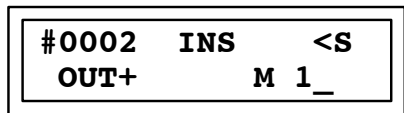

Press the  key:

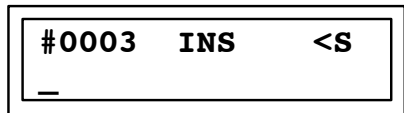

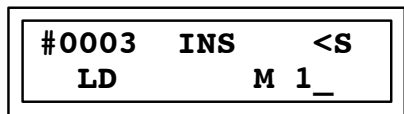

Press the key sequence



Press the  key:

```
#0004  INS  <S  
_
```

Press the key sequence



   :

```
#0004  INS  <S  
FUNC   32_  ROL
```

Press the  key:

```
#0004  INS  <S  
P01  _
```

Press the key sequence

   :

```
#0005  INS  <S  
P01   R 30_
```

Press the  key:

```
#0004  ROL  <S  
P02  _
```

Press the key sequence  :

```
#0005  ROL  <S  
P02   2_
```

Press the  key:

```
#0004  ROL  <S  
P03  _
```

Press the key sequence  :

```
#0004  ROL  <S  
P03   3_
```

Press the  key:

```
#0004 ROL <S
P04 _
```

Press the key sequence



  :

```
#0005 ROL <S
P04 R 2_
```

Press the  key:

```
#0005 INS <S
_
```

Press the key sequence

   :

```
#0005 INS <S
OUT Q 1_
```

Press the  key:

```
#0006 INS <S
_
```

Bit Rotate Right (ROR) Function 33

The bit rotate right function (ROR) is a conditionally executed function which rotates all bits in a word array right a given number of bit positions.

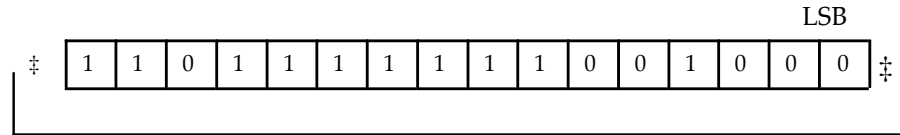

When the logic controlling the enable input to the function passes power flow to the enable (EN) input the function is executed by the CPU. During the execution all of the bits in a word or a group of consecutive 16 bit words connected together to form a continuous string of bits are shifted right a specified number of memory bit locations. The bits which are shifted out of the right end (lowest bit location) of the group of bits are shifted into the vacant locations at the left end (highest bit location) of the group of bits

The location of the word or group of words is specified by parameter P1 which is the memory address location for the first word of the group of consecutive words containing the group of bits to be rotated.

The number of 16 bit words in the consecutive group of words forming the continuous string of bits is specified by parameter P3 (LEN). The limits of LEN depend on the memory type being used and the starting address of the first word of the group of words containing the bits to be shifted, and the starting address of the final memory location where the shifted bits are to be stored. If the length plus the memory address exceed the total number of words for that memory type DATA ERR will be displayed on the screen of the Hand-Held Programmer.

The number of bit locations that each bit is shifted each time this function is executed is specified by parameter P2 (N). The number of location specified by N must be more than zero and less than the total number of bits in the group of consecutive words.

When the shift occurs a number of bits specified by N will be shifted out of the right end (lowest bit location) of the first word of the group of bits. These bits are shifted into the vacant locations created by the shift which is located at the left end (highest bit location) of the group of bits

If the number of bits to rotate (N) is greater than the specified length of the array (LEN) in bits and there is power flow into the ROR function, then the entire output array will be set equal to the input array and power flow out of ROR will be off. If power flow into ROR is ON and no error is detected, then power flow out of ROL is on.

The results of the shifted operation is stored in the location of the word or group of consecutive words which is specified by parameter P4 (Q) which is the memory address location for the first word of the group of consecutive words containing the string of bits that has been shifted.

Parameters P1, P2 and P4 are 16 bit word memory locations representing 16 bit words, and parameter P3 is a constant. If discrete memory types are used for parameters P1, P2, and P4 the beginning address must be on an 8 point boundary.

Power flow through this function occurs only when the functions enable input is receiving power flow and no faults occur. If a fault occurs, power flow output will be off.

To prevent multiple rotations from taking place it is advisable to have the power flow to the enable input be controlled by a contact of a one shot element (OUT+ or OUT-).

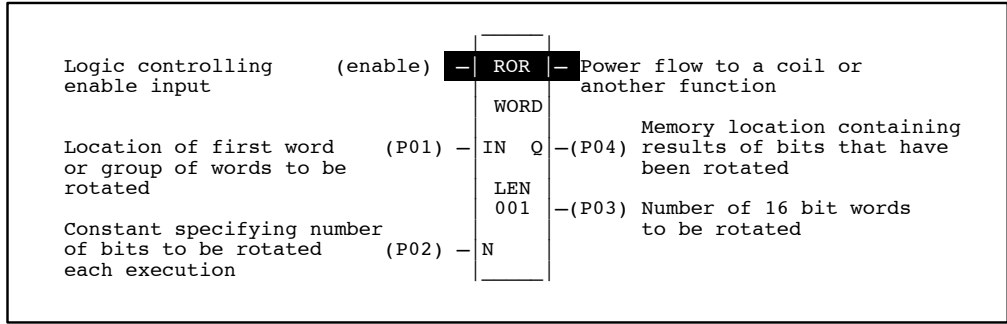

Programming Elements and Sequential Order of Programming

1. Logic controlling the enable input from the left bus. This must start with an LD element.
2. Type of function: Function 33 (ROR).
3. Parameter P1 (IN): the memory address location for the first word of the group of words containing the bits to be rotated.
4. Parameter P2 (N): the number of bits to be rotated each time a shift takes place. This can be a constant or a memory location where the value is stored.
5. Parameter P3: a constant specifying the number of words (each word is 16 bits long) that will be connected together to form the total number of bits in the group.
6. Parameter P4 (Q): the memory address location where the first word of the group of words containing the results of the bits that have been rotated is to be stored.

The following table specifies which memory types are valid for each of the ROR function parameters:

Allowable Memory Types for ROR (Function 33)

Parameter	%I	%Q	%M	%T	%G	%S	%R	%AI	%AQ	Constant
Input IN (P01)	•	•	•	•	•	•	•	•	•	
Distance N (P02)	•	•	•	•	•		•	•	•	•
Length LEN (P03)										•
Output Q (P04)	•	•	•	•	•	•†	•	•	•	

† Only %SA, %SB, and %SC are used. %S cannot be used.

Programming Example for ROR Function

In the following example a contact for a one shot (OUT+) is used as the controlling element for power flow to the enable function. When input one closes (passes power flow), %M0001 will pass power flow to the input of the ROR function for one sweep of the CPU scan. Therefore ROR will occur only once. When the ROR function takes place the 48 bits of register %R0032, %R0033 and %R0034 specified by parameter P1 will rotate right two bit spaces $N(P2)=2$

The result will be placed into the 16-bit words of registers %R0032, %R0033 and %R0034 specified by parameter P4 (any register or memory location could have been used here, it does not have to be the same as the input location). Parameter P2 is a constant of 2 specifying the number of bits (which will be 2) to be rotated (shifted) each time a rotate is executed. P3 parameter specifies the number of words that will be connected together to form the total number of bits in the word, which for this example is three words.

Before Rotate Right:

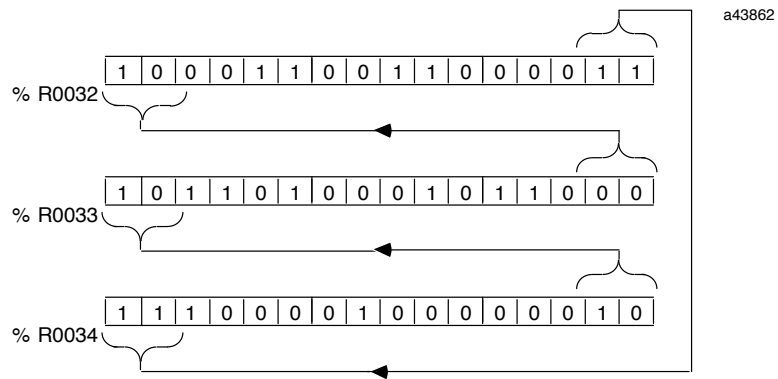

After Rotate Right:

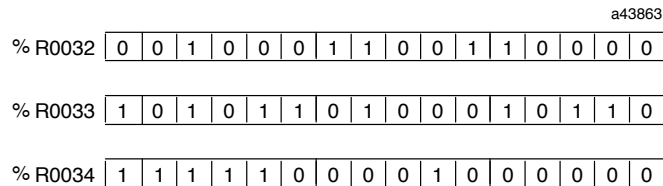

Ladder Diagram Representation

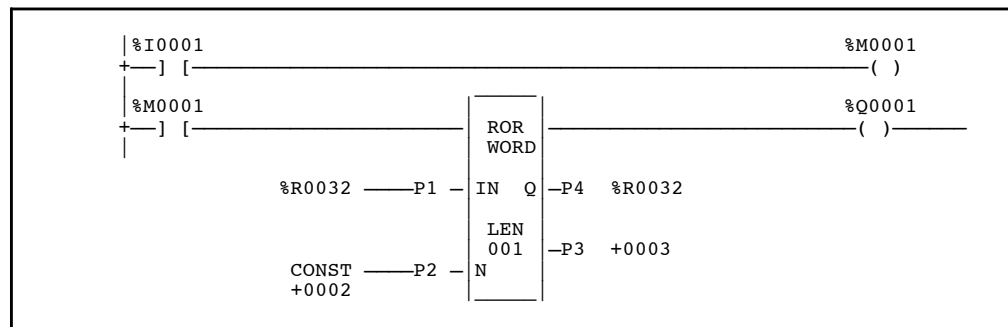

Statement List Representation:

#0001:	LD		%I0001
#0002:	OUT+		%M0001
#0003:	LD		%M0001
#0004:	FUNC	33	ROR
		P1:	%R0032
		P2:	+0002
		P3:	+0003
		P4:	%R0032
0005:	OUT		%Q0001

After pressing  key: Programming sequence



Key Strokes

HHP Display

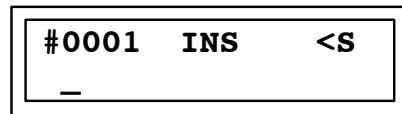
Initial display:



Press the key sequence



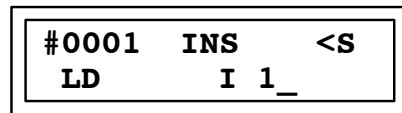

   :

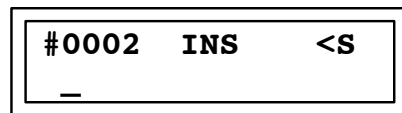

Press the  key:



Press the key sequence

    :

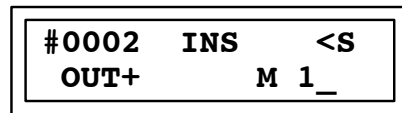

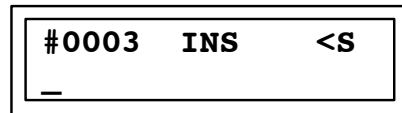

Press the  key:



Press the key sequence

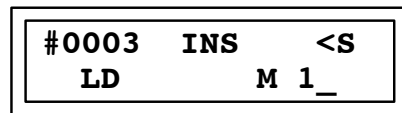

   :



Press the  key:

```
#0004  INS  <S  
_
```

Press the key sequence



   :

```
#0004  INS  <S  
FUNC    33_ ROR
```

Press the  key:

```
#0004  ROR  <S  
P01  _
```

Press the key sequence

   :

```
#0004  ROR  <S  
P01    R  32_
```

Press the  key:

```
#0004  ROR  <S  
P02  _
```

Press the key sequence  :

```
#0004  ROR  <S  
P02    2_
```

Press the  key:

```
#0004  ROR  <S  
P03  _
```



Press the key sequence  :

```
#0004  ROR  <S  
P03    3_
```

Press the  key:

```
#0004 ROR <S
P04 _
```

Press the key sequence



   :

```
#0004 ROR <S
P04 R 32_
```

Press the  key:

```
#0005 INS <S
_
```

Press the key sequence

   :

```
#0005 INS <S
OUT Q 1_
```

Press the  key:

```
#0006 INS <S
_
```

Bit Set (BITSET) Function 22

The Bit Set function (BITSET) is a conditionally executed function which is used to SET a particular bit in a string of bits to a 1.

When the logic controlling the enable input to the function passes power flow to the enable (EN) input, the function is executed by the CPU and a new bit set function will take place.

The IN parameter specifies the beginning of the bit string. The BIT parameter specifies the number of the bit to be set in the bit string. Bits in the bit string are numbered beginning with 1, starting with the least significant bit to the most significant bit. The LEN parameter specifies the length of the bit string in words. The state of the power flow output is determined by the ability of the function block to operate properly based upon the value of the parameters at the time of execution.

Since the BIT parameter can be specified from a word in a reference table, it is possible that a bit number greater than the length of the bit string could be encountered by the function block. In this case, the function block cannot execute, the power flow output is 0 and the contents of the bit string are not affected. If the function block can execute properly, the power flow output is a 1 and the bit specified by parameters P1 (IN) and P2 (BIT) is set to 1.

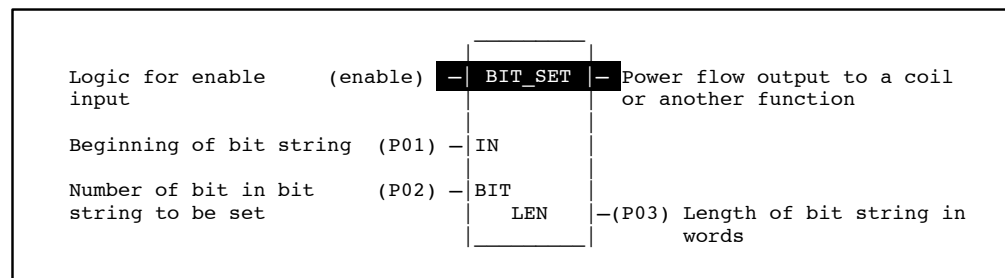

Programming Elements and Sequential Order of Programming

1. Logic controlling the enable input from the left bus. This must start with an LD element.
2. Type of function: Function 22 (BITSET).
3. Parameter P1 (IN): the memory address location for the first word in the bit string containing the bit to be set.
4. Parameter P2 (BIT): the number of the bit in the bit string to be set. This can be a constant or a memory location containing the value.
5. Parameter P3 (LEN): specifies the length of the bit string in words. This is a constant number.

The following table specifies which memory types are valid for each of the BITSET function parameters:

Allowable Memory Types for BITSET (Function 22)

Parameter	%I	%Q	%M	%T	%S	%SA	%SB	%SC	%G	%R	%AI	%AQ	Constant
IN(P01)	•	•	•	•		•	•	•	•	•	•	•	
BIT(P02)	•	•	•	•					•	•	•	•	•
LEN(P03)													•

Programming Example for BITSET Function

In this example, the discrete reference %M0027 in the bit string %M0017 - %M0080 will be set to 1 when the function is executed. Since the BIT parameter is a constant and less than LEN x 16, the power flow output will be set to 1.

Ladder Diagram Representation

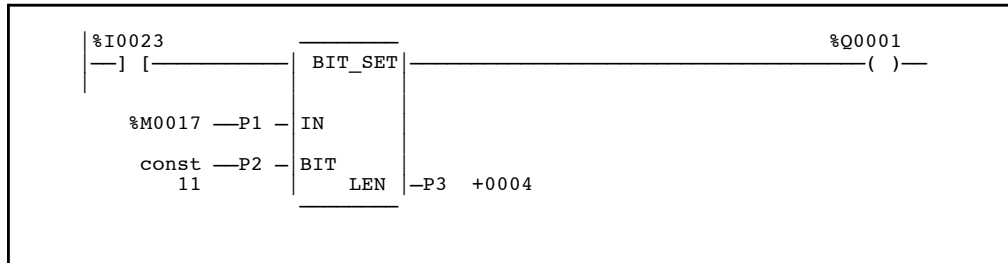

Statement List Representation

```

#0001    LD          %I0023
#0002    FUNC        22          BITSET
                P1:      %M0017
                P2:      11
                P3:      4
#0003    OUT          %Q0001
    
```

After pressing INS key: Programming sequence

Key Strokes

HHP Display

Initial display:

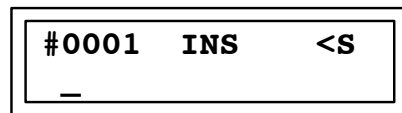

Press the key sequence

LD $\frac{A}{AI}$ 2 3 :

```
#0001  INS  <S  
LD      I 23_
```

Press the  key:

```
#0002  INS  <S  
_
```

Press the key sequence

FUNC 2 2 :

```
#0002  INS  <S  
FUNC 22_ BITSET
```

Press the  key:

```
#0002  BITSET <S  
P01  _
```

Press the key sequence

$\frac{C}{M}{T}$ 1 7 :

```
#0002  BITSET <S  
P01 M 17_
```

Press the  key:

```
#0002  BITSET <S  
P02  _
```

Press the key sequence 1 1 :

```
#0002  BITSET <S  
P02   11_
```

Press the  key:

```
#0002  BITSET <S  
P03  _
```



Press the key sequence 4 :

```
#0002  BITSET <S  
P03   4_
```

Press the  key:

```
#0003  INS  <S  
_
```

Press the key sequence

   :

```
#0003  INS  <S  
OUT  Q  1_
```

Press the  key:

```
#0004  INS  <S  
_
```

Bit Clear (BITCLR) Function 24

The Bit Clear function (BITCLR) is a conditionally executed function which is used to SET a particular bit in a string of bits to 0.

When the logic controlling the enable input to the function passes power flow to the enable (EN) input, the function is executed by the CPU and a new bit clear function will take place.

The IN parameter specifies the beginning of the bit string. The BIT parameter specifies the number of the bit to be set in the bit string. Bits in the bit string are numbered beginning with 1, starting with the least significant bit to the most significant bit. The LEN parameter specifies the length of the string bit in words. The state of the power flow output is determined by the ability of the function block to operate properly based upon the value of the parameters at the time of execution.

Since the BIT parameter can be specified from a word in a reference table, it is possible that a bit number greater than the length of the bit string could be encountered by the function block. In this case, the function block cannot execute, the power flow output is 0 and the contents of the bit string are not affected. If the function block can execute properly, the power flow output is a 1 and the bit specified by IN and BIT is set to 0.

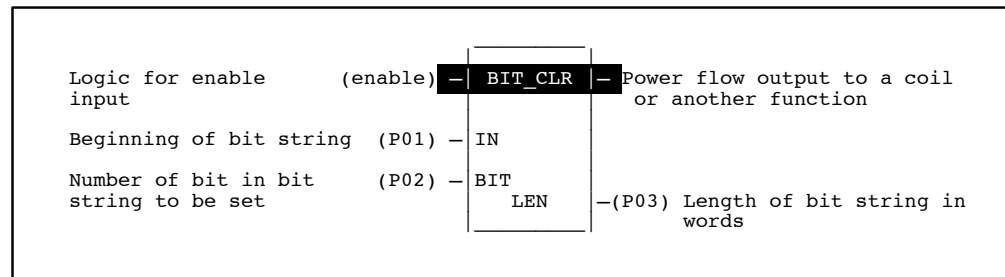

Programming Elements and Sequential Order of Programming

1. Logic controlling the enable input from the left bus. This must start with an LD element.
2. Type of function: Function 24 (BITCLR).
3. Parameter P1 (IN): the memory address location for the first word in the bit string containing the bit to be set.
4. Parameter P2 (BIT): the number of the bit in the bit string to be set. This can be a constant or a memory location containing the value.
5. Parameter P3 (LEN): specifies the length of the bit string in words. This is a constant number.

The following table specifies which memory types are valid for each of the BITCLR function parameters:

Allowable Memory Types for BITCLR (Function 24)

Parameter	%I	%Q	%M	%T	%S	%SA	%SB	%SC	%G	%R	%AI	%AQ	Constant
IN (P01)	•	•	•	•		•	•	•	•	•	•	•	
BIT (P02)	•	•	•	•					•	•	•	•	•
LEN (P02)													•

Programming Example for BITCLR Function

In this example, the discrete reference %M0244 in the bit string %M0233 - %M0280 will be set to 0 when the function is executed. Since the BIT parameter is a constant and less than LEN x 16, the power flow output will be set to 1.

Ladder Diagram Representation

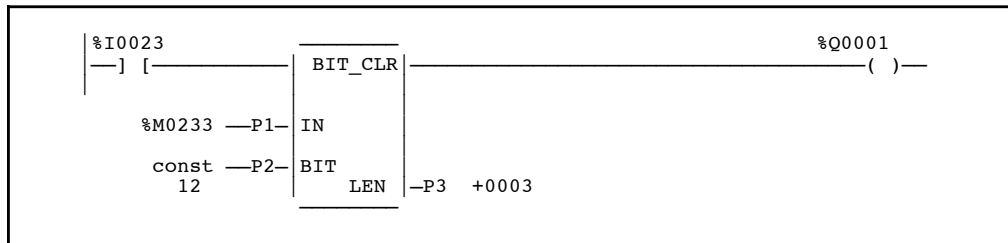

Statement List Representation

```

#0001    LD          %I0023
#0002    FUNC      24  BITCLR
           P1:      %M0233
           P2:      12
           P3:      3
#0003    OUT          %Q0001
    
```

After pressing  key: Programming sequence

Key Strokes

HHP Display

Initial display:

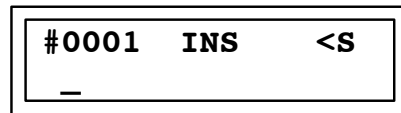

Press the key sequence

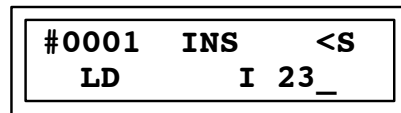

Press the  key:

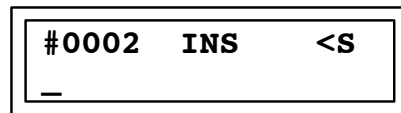

Press the key sequence

FUNC **2** **4** :

```
#0002  INS  <S  
FUNC 24_ BITCLR
```

Press the **ENT** key:

```
#0002  BITCLR <S  
P01  _
```

Press the key sequence

C
M
T **2** **3** **3** :

```
#0002  BITCLR <S  
P01 M 233_
```

Press the **ENT** key:

```
#0002  BITCLR <S  
P02  _
```

Press the key sequence **1** **2** :

```
#0002  BITCLR <S  
P02  12_
```

Press the **ENT** key:

```
#0002  BITCLR <S  
P03  _
```

Press the key sequence **3** :

```
#0002  BITCLR <S  
P03  3_
```

Press the **ENT** key:

```
#0003  INS  <S  
_
```

Press the key sequence

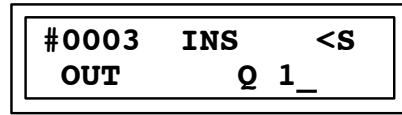
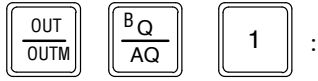

Press the  key:

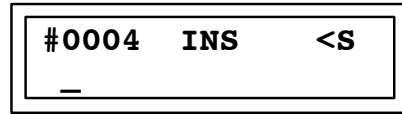

Bit Test (BITTST) Function 26

The Bit Test function (BITTST) is a conditionally executed function which is used to determine if a particular bit in a string of bits is set to 1 or 0.

When the logic controlling the enable input to the function passes power flow to the enable (EN) input, the function is executed by the CPU and a new Bit Test function will take place.

The IN parameter specifies the beginning of the bit string. The BIT parameter specifies the number of the bit to be tested in the bit string. Bits in the bit string are numbered beginning with 1, starting with the least significant bit to the most significant bit. The LEN parameter specifies the length of the string bit in words. The output (Q) of the function block is set to the current state (1 or 0) of the tested bit.

The BITTST function has the possibility of not being able to execute properly since the BIT parameter can be specified from a word in a reference table and a bit number greater than the length of the bit string could be encountered at the time of execution. However, there is not a power flow output to indicate failure of the function block to execute. When this error situation occurs the function block output Q will be 0.

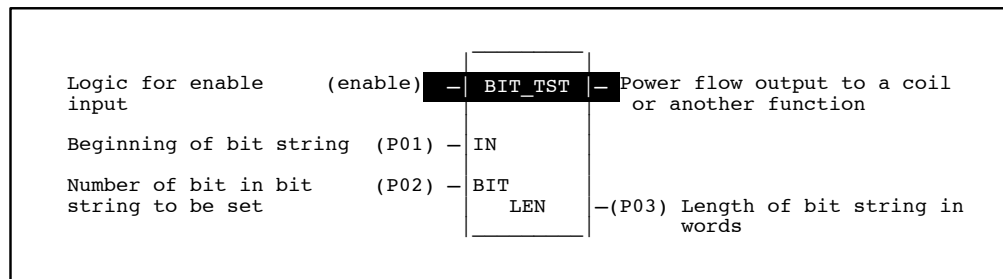

Programming Elements and Sequential Order of Programming

1. Logic controlling the enable input from the left bus. This must start with an LD element.
2. Type of function: Function 26 (BITTST).
3. Parameter P1 (IN): the memory address location for the first word in the bit string containing the bit to be set.
4. Parameter P2 (BIT): the number of the bit in the bit string to be tested. This can be a constant or a memory location containing the value.
5. Parameter P3 (LEN): specifies the length of the bit string in words. This is a constant number.

The following table specifies which memory types are valid for each of the BITTST function parameters:

Allowable Memory Types for BITTST (Function 26)

Parameter	%I	%Q	%M	%T	%S	%SA	%SB	%SC	%G	%R	%AI	%AQ	Constant
IN(P01)	•	•	•	•	•	•	•	•	•	•	•	•	
BIT(P02)	•	•	•	•					•	•	•	•	•
LEN(P03)													•

Programming Example for BITTST Function

In this example, output Q of the function block will be set to the current state of %I0007 in the bit string %I0001 -%I0032.

Ladder Diagram Representation

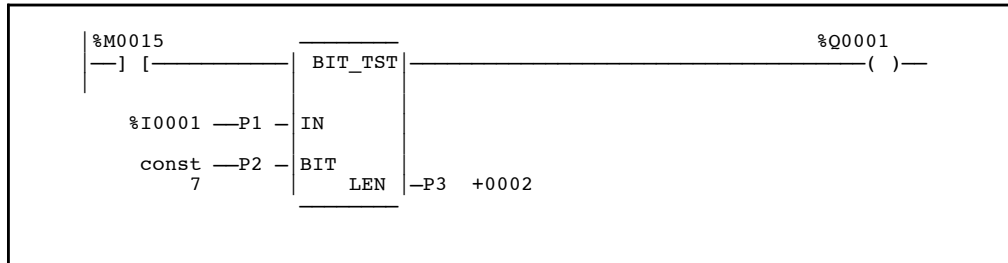

Statement List Representation

#0001	LD		%M0015
#0002	FUNC	26	BITTST
		P1:	%I0001
		P2:	7
		P3:	2

After pressing  key: Programming sequence

Key Strokes

HHP Display

Initial display:

#0001 INS <S
_

Press the key sequence



  1 5 :

#0001 INS <S
LD M 15_

Press the  key:

#0002 INS <S
_



Press the key sequence

   :

```
#0002  INS  <S
FUNC 26_ BITTST
```

Press the  key:

```
#0002  BITTST <S
P01  _
```

Press the key sequence   :

```
#0002  BITTST <S
P01      I 1_
```

Press the  key:

```
#0002  BITTST <S
P02  _
```

Press the key sequence  :

```
#0002  BITTST <S
P02   7_
```

Press the  key:

```
#0002  BITTST <S
P03  _
```

Press the key sequence  :

```
#0002  BITTST <S
P03   2_
```

Press the  key:

```
#0003  INS  <S
_
```

Bit Position (BITPOS) Function 28

The Bit Position function (BITPOS) is a conditionally executed function which is used to determine which bit in a string of bits is set to 1.

When the logic controlling the enable input to the function passes power flow to the enable (EN) input, the function is executed by the CPU and a new Bit Position function will take place.

The IN parameter specifies the beginning of the bit string and LEN specifies the length of the bit string in words. When executed, the function block searches the bit string starting with the least significant bit until either a bit equal to 1 is found or the length of the string is searched. If a bit equal to 1 is found, the bit number within the bit string is written to the POS parameter. Bits are numbered in the bit string beginning with 1 and starting with the least significant bit to the most significant bit. If a bit equal to 1 is not found in the bit string, a 0 is written to the POS parameter. In either case, the function block power flow output is a 1 whenever the function block is executed.

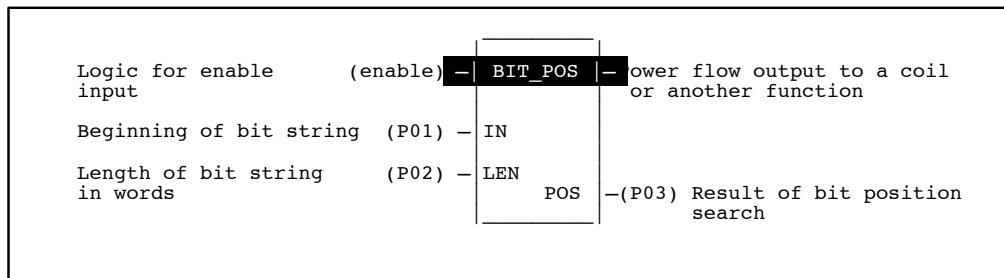

Programming Elements and Sequential Order of Programming

1. Logic controlling the enable input from the left bus. This must start with an LD element.
2. Type of function: Function 28 (BITPOS).
3. Parameter P1 (IN): the memory address location for the first word in the bit string containing the bit to be set.
4. Parameter P2 (LEN): specifies the length of the bit string (in words) to be searched.
5. Parameter P3 (POS): contains the result of the bit position search. This is a memory location where the result is stored.

The following table specifies which memory types are valid for each of the BITPOS function parameters:

Allowable Memory Types for BITPOS (Function 28)

Parameter	%I	%Q	%M	%T	%S	%SA	%SB	%SC	%G	%R	%AI	%AQ	Constant
IN (P01)	•	•	•	•	•	•	•	•	•	•	•	•	
LEN (P02)													•
POS (P03)	•	•	•	•					•	•	•	•	

Programming Example for BITPOS Function

In this example, the bit string %G0017 -%G0080 is searched starting at %G0017 for a bit that is set to 1. Assume that the value of word %G0017 = 0, word %G0033 = 4H, word %G0049 = 80H, and word %G0065 = 0A40H at the time the function block is executed. The word %Q0233 will be set to 19 decimal. The function block output OK will be a 1.

Ladder Diagram Representation

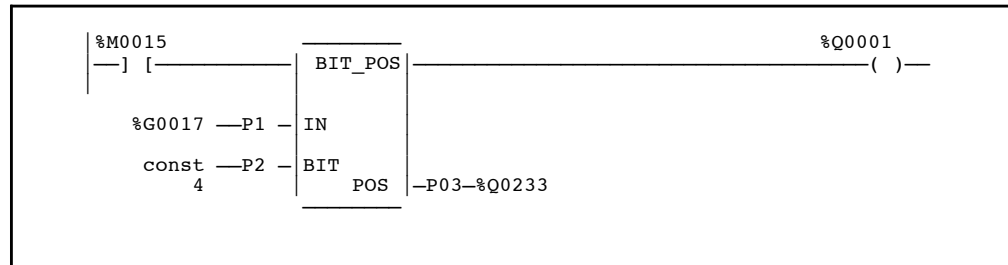

Statement List Representation

```

#0001  LD          %M0015
#0002  FUNC      28  BITPOS
          P1:    %G0017
          P2:    4
          P3:    %Q0233
#0003  OUT          %Q0001
    
```

After pressing INS key: Programming sequence

Key Strokes

HHP Display

Initial display:

```
#0001  INS  <S
_
```

Press the key sequence

LD

C
M
T

1
5
:

```
#0001  INS  <S
LD      M 15_
```

Press the ENT key:

```
#0002  INS  <S
_
```

Press the key sequence

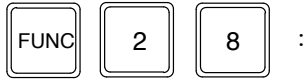

```
#0002  INS  <S  
FUNC 28 BITPOS
```

Press the  key:

```
#0002  BITPOS <S  
P01  _
```

Press the key sequence



```
#0002  BITPOS <S  
P01 G17 _
```

Press the  key:

```
#0002  BITPOS <S  
P02  _
```

Press the key sequence  :

```
#0002  BITPOS <S  
P02      4 _
```

Press the  key:

```
#0002  BITPOS <S  
P03  _
```



Press the key sequence



```
#0002  BITPOS <S  
P03 Q233 _
```

Press the  key:

```
#0003  INS  <S  
_
```

Press the key sequence   :

#0003	INS	<S
OUT	Q 1_	

Press the  key:

#0004	INS	<S
_		

Masked Compare Word (MSKCOMPW) Function 143

Masked Compare Dword (MSKCOMPD) Function 144

The Masked Compare function is used to compare the contents of two bit strings with the ability to mask selected bits. The length of the bit strings to be compared is specified by the LEN parameter where the value of LEN specifies the number of 16 bit words for MSKCOMPW and 32 bit words for MSKCOMPD.

When the logic controlling the enable input to the function passes power flow to the enable input, the function begins comparing the bits in the first string (I1) with the corresponding bits in the second string (I2). Comparison continues until a miscompare is found, or until the end of the string is reached.

The BIT input is used to store the bit number where the next comparison should start with a 0 indicating the first bit in the string. The BN output is used to store the bit number where the last comparison occurred; a 1 indicates the first bit in the string. Using the same reference for BIT and BN causes the compare to start at the next bit position after a miscompare or at the beginning if all bits compared successfully upon the next execution of the function block.

If you want to start the next comparison at some other location in the string, you can enter different references for BIT and BN. If the value of BIT is a location that is beyond the end of the string, BIT is reset to a 0 before starting the next comparison.

IF all Bits in I1 and I2 are the Same

If all corresponding bits in strings I1 and I2 match, the function sets the miscompare output (MC) to 0 and BN to the highest bit number in the input strings. The comparison then stops. On the next execution of the Masked Compare, it will be reset to 0.

If a Miscompare is Found

When the two bits currently being compared are not the same, the function then checks the corresponding numbered bit in string M (the mask). If the mask bit is a 1, the comparison continues until another miscompare or the end of the input strings is reached.

If a miscompare is detected and the corresponding mask bit is a 0, the function:

1. Sets the corresponding mask bit in M to a 1.
2. Sets the miscompare (MC) output to 1.
3. Updates the output bit string Q to match the new content of mask string M.
4. Sets the bit number output (BN) to the number of the miscompared bit.
5. Stops the comparison.

(Logic for controlling (enable) power flo)	-	MASK COMP WORD	
(Starting address of first bit string to be compared)	(P1) -	I1 MC	-(Logic set by miscompare)
(Starting address of second bit string to be compared)	(P2) -	I2 I2	-(P5) (Number of words in bit string)
(Starting address of bit string mask)	(P3) -	M	Q -(P6) (Output copy of mask (M) bit string)
(Address for bit location for start of next comparison)	(P4) -	BIT	BN -(P7) (Reference containing bit number of last compare)

Programming Elements and Sequential Order of Programming

1. Logic controlling the enable input from the left bus. This must start with an LD element.
2. Type of function: Function 143 (MSKCMPW) or Function 144 (MSKCMPD).
3. Parameter P1 (I1): the starting memory address of the first bit string to be compared.
4. Parameter P2 (I2): the starting memory address of the second bit string to be compared.
5. Parameter P3 (M): the starting memory address of the bit string mask.
6. Parameter P4 (BIT): specifies the location of the bit number where the next comparison should start.
7. Parameter P5 (LEN): the number of words (16-bit words for MSKCMPW; 32-bit words for MSKCMPD) in the bit string.
8. Parameter P6 (Q): output copy of the bit string mask (M).
9. Parameter P7 (BN): memory location where the last compare occurred.

The following table specifies which memory types are valid for the Masked Compare function parameters:

Allowable Memory Types for Masked Compare Functions

Parameter	flow	%I	%Q	%M	%T	%S	%G	%R	%AI	%AQ	const	none
enable	•											
I1 (P01)		o	o	o	o	o	o	•	•	•		
I2 (P02)		o	o	o	o	o	o	•	•	•		
M (P03)		o	o	o	o	o†	o	•	•	•		
BIT (P04)		•	•	•	•	•	•	•	•	•	•	
LEN (P05)											•‡	
MC	•											•
Q (P06)		o	o	o	o	o†	o	•	•	•		
BN (P07)		•	•	•	•	•	•	•	•	•	•	

- = Valid reference or place where power may flow through the function.
- o = Valid reference for WORD data only; not valid for DWORD.
- † = %SA, %SB, %SC only; %S cannot be used.
- ‡ = Max const value of 4095 for WORD and 2047 for DWORD.

Programming example for MSKCMPW Function

In the following example, when %I0001 is TRUE, the MSKCMPW function block is executed. %M0001 through %M0016 is compared with %M0017 through %M0032. %M0033 through %M0048 contains the mask value. The value in %R0001 determines at which bit position the comparison starts within the two input strings. The contents of these references before the function block is executed are as follows:

(I1) %M0001 =

0	1	1	0	1	1	0	0	0	1	1	0	1	1	0	0
---	---	---	---	---	---	---	---	---	---	---	---	---	---	---	---

(I2) %M0017 =

0	1	1	0	1	1	0	1	0	1	1	0	1	1	1	1
---	---	---	---	---	---	---	---	---	---	---	---	---	---	---	---

(M/Q) %M0033 =

0	0	0	0	0	0	0	0	0	0	0	0	0	1	1	1	1
---	---	---	---	---	---	---	---	---	---	---	---	---	---	---	---	---

(BIT / BN) %R0001 = 9
 (MC) %Q0001 = FALSE

The contents of these references after the function block is executed are as follows:

(I1) %M0001 =

0	1	1	0	1	1	0	0	0	1	1	0	1	1	0	0
---	---	---	---	---	---	---	---	---	---	---	---	---	---	---	---

(I2) %M0017 =

0	1	1	0	1	1	0	1	0	1	1	0	1	1	1	1
---	---	---	---	---	---	---	---	---	---	---	---	---	---	---	---

(M/Q) %M0033 =

0	0	0	0	0	0	0	1	0	0	0	0	0	1	1	1	1
---	---	---	---	---	---	---	---	---	---	---	---	---	---	---	---	---

(BIT / BN) %R0001 = 9
 (MC) %Q0001 = TRUE

Ladder Diagram Representation

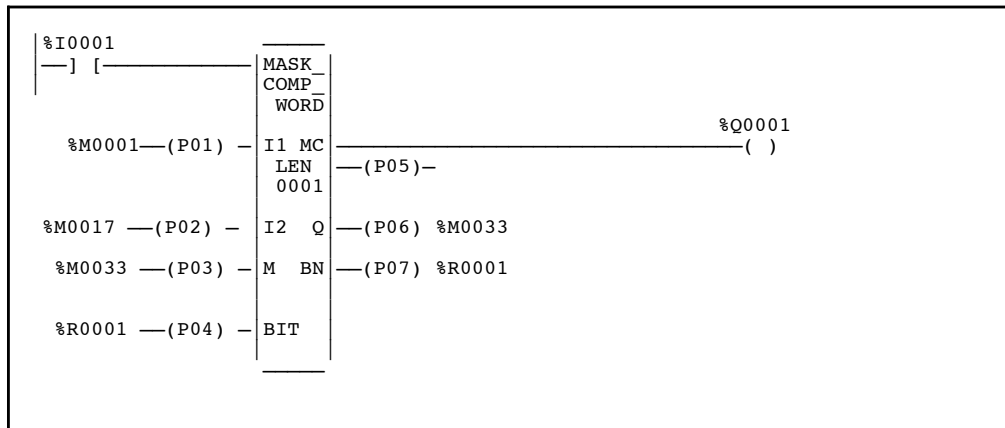

Statement List Representation

```

#0001: LD %I0001
#0002: FUNC 143 MSKCOMPW
      P01: %M0001
      P02: %M0017
      P03: %M0033
      P04: %R0001
      P05: 1
      P06: %M0033
      P07: %R0001
#0003: OUT %Q0001
    
```

After pressing INS key: Programming sequence

Key Strokes

HHP Display

Initial display:

#0001 INS <S
_

Press the key sequence

LD

 $\frac{A}{AI}$
1
:

#0001 INS <S
LD I 1_

Press the  key:

```
#0002  INS  <S  
_
```



Press the key sequence

    :

```
#0002  INS  <S  
FUNC 143_MSKCMPW
```

Press the  key:

```
#0002 MSKMPW <S  
P01 _
```

Press the key sequence   :

```
#0002 MSKMPW <S  
P01      M 1_
```

Press the  key:

```
#0002 MSKMPW <S  
P02 _
```

Press the key sequence:

```
#0002 MSKMPW <S  
P02 _      M17_
```

Press the  key:

```
#0002 MSKMPW <S  
P03 _
```

Press the key sequence:

```
#0002 MSKMPW <S  
P03      M33_
```

Press the  key:

```
#0002 MSKCOMPW <S
P04 _
```

Press the key sequence

```
#0002 MSKCOMPW <S
P04      R 1_
```

Press the  key:

```
#0002 MSKCOMPW <S
P05 _
```

Press the  key :

```
#0002 MSKCOMPW <S
P05      1_
```

Press the  key:

```
#0002 MSKCOMPW <S
P06 _
```

Press the key sequence

   :

```
#0002 MSKCOMPW <S
P06      M33_
```

Press the  key:

```
#0002 MSKCOMPW <S
P07 _
```

Press the key sequence



 

```
#0002 MSKCOMPW <S
P07 _      R 1_
```

Press the  key:

```
#0003  INS  <S  
_
```

Press the key sequence

   :

```
#0003  INS  <S  
OUT      Q 1_
```

Press the  key:

```
#0004  INS  <S  
_
```

Section 5: Data Move Functions

Data Move functions provide move (single word, constant, and word array), initialization, shift register, bit sequencer, and communications request operations.

Abbreviation	Function	Description
MOVEN	Move	Copies data as an array of multiple 16-bit words. Data can thus be moved into a different data type without prior conversion.
MOVBN	Move Bits	Move one or more bits from one reference to another.
BMOVE	Block Move	Copies a block of seven constants to a specified memory location. The constants are input as part of the function.
BLKCL	Block Clear	Replaces the content of a block of data with all zeros. This function may be used to clear an area of bit memory (%I, %Q, %M, and %T) or word memory (%R, %AI, or %AQ).
SHFR SEQB	Shift Register	Fills an area of memory with selected data.
SHFRB	Shift Register Bit	Implements a shift register which shifts a single specified bit.
COMRQ	Communications Request	Allows the program to communicate with an intelligent module, such as a PCM, or Genius Communications Module.

Descriptions of each of these functions are included in this section.

Multiple Word Move MOVEN (MOVIN and MOVWN) Functions 37 and 42

The multiple (array) word move function (MOVIN or MOVWN) is a conditionally executed function which moves a copy of an array of multiple 16-bit words from one location to another. The MOVEN function has two forms, MOVIN (Function 37) and MOVWN (Function 42). The two functions differ only in the default display format applied to their parameters, signed integer will be displayed for the MOVIN function and hexadecimal will be displayed for the MOVWN function.

The location of the word or group of words to be copied is specified by parameter P1 which is the memory address location for the first word of the group of consecutive words to be copied.

The number of 16 bit words in the consecutive group of words to be copied is specified by parameter P2 (LEN). The limits of LEN depend on the memory type being used and the starting address of the first word of the group of words to be copied, and the starting address of the final memory location where the words have been copied to. If the length plus the memory address exceed the total number of words for that memory type DATA ERR will be displayed on the screen of the Hand-Held Programmer.

The group of words are copied to a location in memory that is specified by parameter P3 (Q) which is the memory address location for the first word of the group of consecutive words that have been copied or is loaded with the same constant value as specified by P1, when P1 is a constant.

Parameters P1 and P3 are word memory locations representing 16 bit words. If discrete memory types are used for parameters P1 and P3 the beginning address must be on an 8 point boundary.

Power flow through this function occurs only when the functions enable input is receiving power flow.

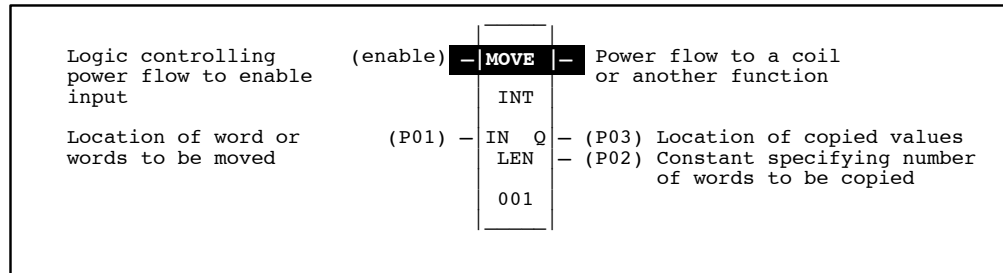

Programming Elements and Sequential Order of Programming

1. Logic controlling the enable input from the left bus. This must start with an LD element.
2. Type of function: Function 37 (MOVIN) or Function 42 (MOVWN).
3. Parameter P1 (IN): the data to be moved. This can be a constant value or the memory address location for the first word of the group of words containing the bits to be copied.
4. Parameter P2 (LEN): a constant specifying the number of 16 bit words to be copied each time a move takes place. LEN cannot be greater than 256.
5. Parameter P3 (Q): the memory address location where the first word of the group of words that have been copied is stored.

The following table specifies which memory types are valid for each of the MOVEN function parameters:

Allowable Memory Types for MOVIN (Function 37) and MOVWN (Function 42)

Parameter	%I	%Q	%M	%T	%G	%S	%R	%AI	%AQ	Constant
Input IN (P01)	•	•	•	•	•	•	•	•	•	•
Output Q (P03)	•	•	•	•	•	•†	•	•	•	
LEN (P02) ‡										•

† Only %SA, %SB, and %SC are used. %S cannot be used.

‡ LEN cannot be greater than 256.

Programming Example for MOVIN Function

In the following example the contact of a one shot (OUT-) is used as the controlling element for power flow to enable the MOVIN function. When input one closes, power flow from the left bus to %Q0001 is removed and %Q0001 will turn on for one sweep of the CPU scan. This ensures that the move of data will take place only once. When the function is executed, the 16 bit word or words in memory locations %R0001 and %R0002 specified by starting location parameter P1 are copied to memory locations %R0030 and %R0031 specified by parameter P3. The number of words to be copied is specified by the constant 2 specified by parameter P2.

Ladder Diagram Representation

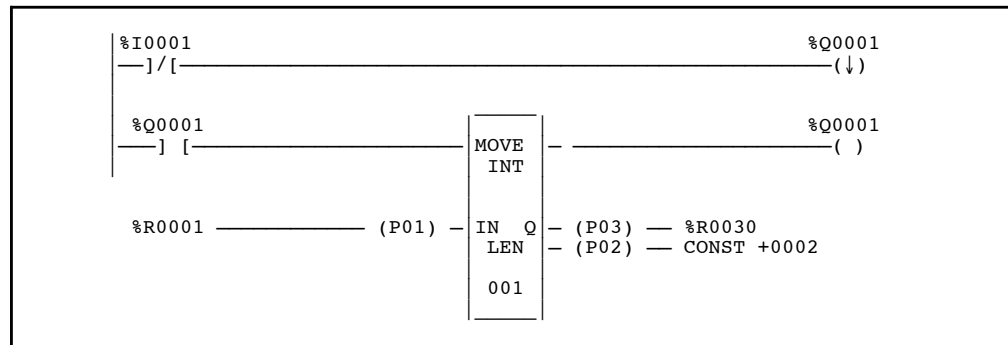

Statement List Representation

```

#0001: LD NOT %I0001
#0002: OUT- %Q0001
#0003: LD %Q0001
#0004: FUNC 37 MOVIN
      P01: %R000
      P02: 2
      P03: %R0030
#0005: OUT %Q0001
  
```

After pressing  key: Programming sequence





Key Strokes

HHP Display

Initial display:

```
#0001  INS  <S
_
```

Press the key sequence





    :

```
#0001  INS  <S
LD  NOT I 1_
```

Press the  key:

```
#0002  INS  <S
_
```

Press the key sequence



     :

```
#0002  INS  <S
OUT-   Q 1_
```

Press the  key:

```
#0003  INS  <S
_
```

Press the key sequence



   :

```
#0003  INS  <S
LD      Q 1_
```

Press the  key:

```
#0004  INS  <S
_
```

Press the key sequence

   :

```
#0004  INS  <S
FUNC 37_  MOVIN
```

Press the  key:

```
#0004  MOVIN  <S  
P01  _
```

Press the key sequence

  :

```
#0004  MOVIN  <S  
P01 R  1_
```

Press the  key:

```
#0004  MOVIN  <S  
P02_
```



Press the key sequence  :

```
#0004  MOVIN  <S  
P02 R  2_
```

Press the  key:

```
#0004  MOVIN  <S  
P03_
```

Press the key sequence



   :

```
#0004  MOVIN  <S  
P03 R  30_
```

Press the  key:

```
#0005  INS    <S  
_
```

Press the key sequence

   :

```
#0005  INS    <S  
OUT           Q  1_
```

Press the  key:

```
#0006  INS    <S  
_
```

Move Bits (MOVBN) Function 40

The Move Bits function (MOVBN) is a conditionally executed function which is used to move one or more bits from one reference to another reference.

When the logic controlling the enable input to the function passes power flow to the enable (EN) input, the function is executed by the CPU and a new move bits function will take place.

The MOVBN function is used to move a bit string from one reference to another reference. The IN parameter specifies the beginning of the bit string and the LEN parameter specifies the length of the bit string in bits. The Q parameter specifies the destination of the move. Any discrete or word reference can be specified for IN and Q within the parameter restrictions as stated below. Since IN and Q are not restricted to a word or byte boundary and LEN is in bits, it is possible to define a bit string that does not occupy an entire byte or word. The unused bits in the byte or word are not affected when the function is executed.

If word memory is specified for IN or Q it is assumed that the first bit position to move from or to is the least significant bit of the word specified by IN or Q. If IN is a constant, the least significant LEN bit of a bit pattern that corresponds to the value of the constant is moved into Q. The power flow output is a 1 whenever the function is executed.

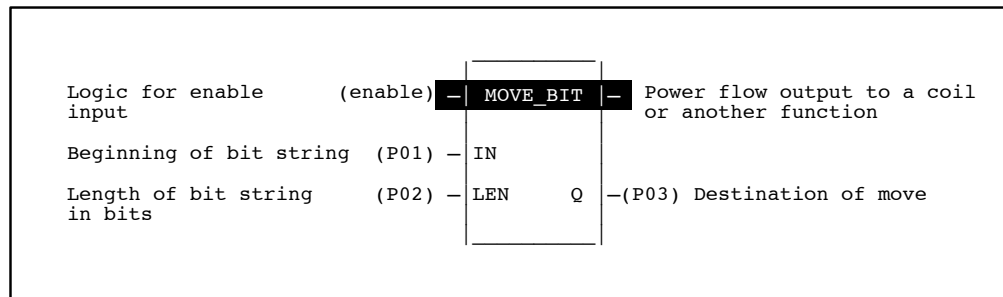

Programming Elements and Sequential Order of Programming

1. Logic controlling the enable input from the left bus. This must start with an LD element.
2. Type of function: Function 40 (MOVBN).
3. Parameter P1 (IN): beginning of the bit string to be moved. This can be a constant value or the memory address location for the first word of the bit string containing the bit or bits to be moved.
4. Parameter P2 (LEN): a constant specifying the number of bits in the bit string that will be moved from one location to another each time a move takes place. The limit for LEN is 16 if the IN parameter is a constant; otherwise the limit is 256.
5. Parameter P3 (Q): the memory address location where the bit or bit string will be moved to.

The following table specifies which memory types are valid for each of the MOVBN function parameters:

Allowable Memory Types for MOVBN (Function 40)

Parameter	%I	%Q	%M	%T	%S	%SA	%SB	%SC	%G	%R	%AI	%AQ	Constant
IN	•	•	•	•	•	•	•	•	•	•	•	•	•
LEN †													•
Q	•	•	•	•		•	•	•	•	•	•	•	

† The limit for LEN is 16 if the IN parameter is a constant; otherwise the limit is 256.

Programming Example for MOVBN Function

In this example, a bit string of 9 bits %I0012 to %I0020 specified by parameter P1 (starting with %I0012) and P2 (constant value of 9) will be moved to the bit string %Q0125 to %Q0133 specified by parameter P3 (%Q0125). The power flow output will be a 1 when the function is executed.

Affected Word	Before Move	After Move
%I0024 - %I0009	0110 1001 1110 1010	0110 1001 1110 1010
%Q0136 - %Q0121	1100 0000 0000 0011	1101 0011 1101 0011

Ladder Diagram Representation

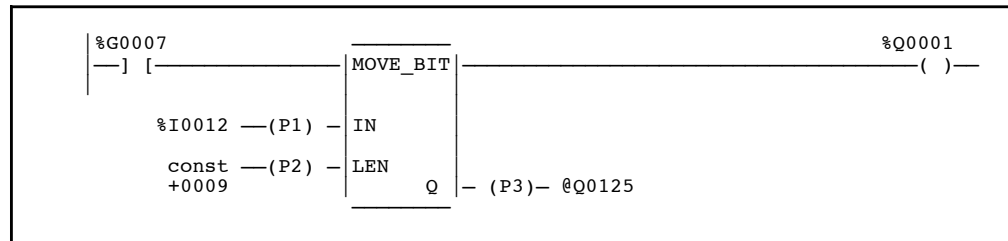

Statement List Representation

```

#0001    LD          %G0007
#0002    FUNC      40    MOVBN
          P1:      %I0012
          P2:      9
          P3:      %Q0125
    
```

After pressing  key: Programming sequence



Key Strokes

HHP Display

Initial display:

```
#0001  INS  <S
_
```

Press the key sequence



   :

```
#0001  INS  <S
LD      G  7_
```

Press the  key:

```
#0002  INS  <S
_
```

Press the key sequence



   :

```
#0002  INS  <S
FUNC 40_ MOVBN
```

Press the  key:

```
#0002  MOVBN <S
P01  _
```

Press the key sequence

   :

```
#0002  MOVBN <S
P01  I12_
```

Press the  key:

```
#0002  MOVBN <S
P02  _
```

Press the key sequence 9 :

```
#0002  MOVBN  <S  
P02      9_
```

Press the ENT
↓ key:

```
#0002  MOVBN  <S  
P03  _
```

Press the key sequence $\frac{B}{AQ}$ 1 2 5 :

```
#0002  MOVBN  <S  
P03      Q125
```

Press the ENT
↓ key:

```
#0003  INS    <S  
_
```

Press the key sequence $\frac{OUT}{OUTM}$ $\frac{B}{AQ}$ 1 :

```
#0003  INS    <S  
OUT      Q 1_
```

Press the ENT
↓ key:

```
#0004  INS    <S  
_
```

Block Move BMOVE (BMOVI and BMOVW) Functions 38 and 43

The constant block move function (BMOVI or BMOVW) is a conditionally executed function which fills seven consecutive words with a block of seven constants. The BMOVE function has two forms, BMOVI (Function 38) and BMOVW (Function 43). The two functions differ only in the default display format applied to their parameters, signed integer for BMOVI and hexadecimal for BMOVW.

The group of constants are copied to locations in memory that are specified by parameter P8 (Q) which is the memory address location for the first word of the seven consecutive memory locations that the constants are being copied into. Each of these memory locations is 16 bits long.

Parameters P1 through P7 are constants representing a 16 bit word. If a discrete memory type is used for parameter P8 the beginning address must be on an 8 point boundary.

To prevent multiple moves from taking place it is advisable to have the power flow to the enable input be controlled by a contact of a one shot element (OUT+ or OUT-). Power flow through this function occurs only when the functions enable input is receiving power flow.

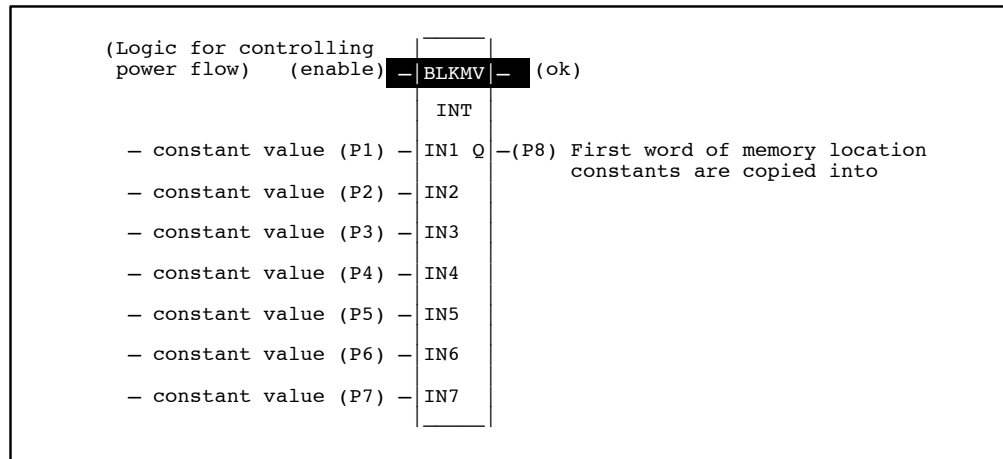

Programming Elements and Sequential Order of Programming

1. Logic controlling the enable input from the left bus. This must start with an LD element.
2. Type of function: Function 38 (BMOVI) or Function 43 (BMOVW).
3. Parameter P1 - P7 (IN1-IN7): value to be copied. The value specified by each of these seven parameters is a constant value representing a 16 bit word.
4. Parameter P8 (Q): the memory address location where the bit or bit string will be moved to.

The following table specifies which memory types are valid for each of the BMOVE function parameters:

Allowable Memory Types for BMOVI (Function 38) and BMOVW (Function 43)

Parameter	flow	%I	%Q	%M	%T	%S	%G	%R	%AI	%AQ	const	none
enable	•											
IN1 - IN7											•	
ok	•											•
Q		•	•	•	•	o†	•	•	•	•		

- = Valid reference for WORD or INT, or place where power may flow through the function.
- o = Valid reference for WORD data only.
- † = %SA, %SB, %SC only; %S cannot be used.

Programming Example for BMOVI Function

In the following example a contact from a one shot (OUT+) is used as the controlling element for power flow to the enable function. When input %I0001 closes (passes power flow), %M0001 will pass power flow to the enable input of the BMOVI function for one sweep of the CPU scan. The Block Move function (BMOVI) copies the seven input constants represented by P1 through P7 into memory locations %R00010 through %R00016.

Ladder Diagram Representation

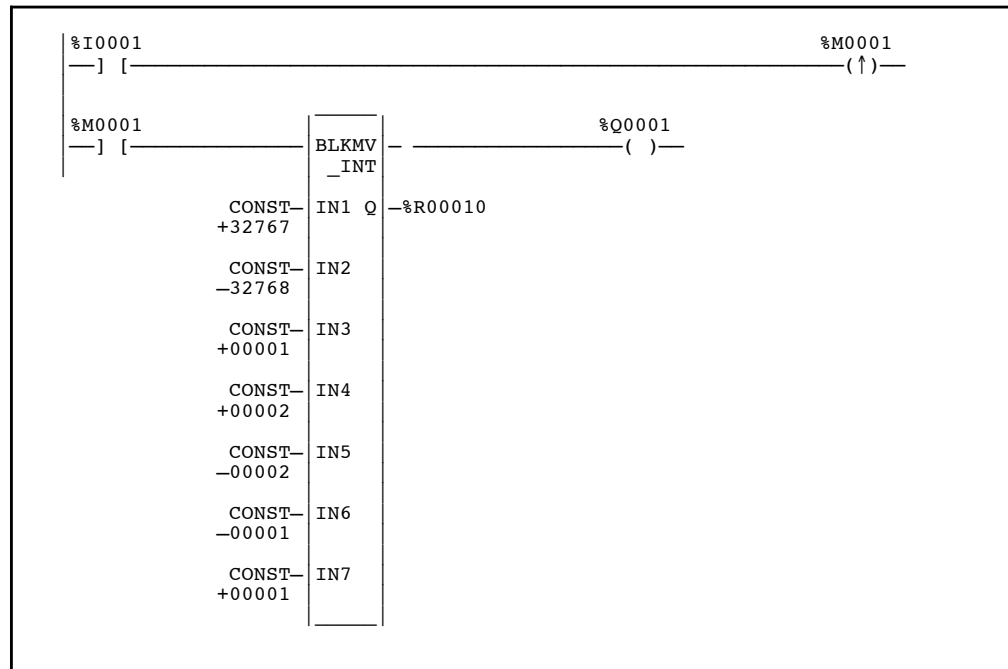

Statement List Representation

```

#0001: LD %I0001
#0002: OUT+ %M0001
#0003: LD %M0001
#0004: FUNC 38 BMOVI
      P1: +32767
      P2: -32768
      P3: 1
      P4: 2
      P5: 2
      P6: 1
      P7: 1
      P8: %R010
#0005: OUT %Q0001
    
```

After pressing  key: Programming sequence



Key Strokes

HHP Display

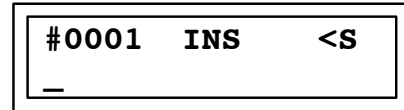
Initial display:



Press the key sequence

   :

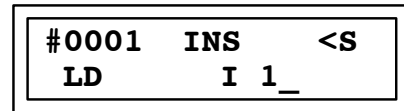

Press the  key:

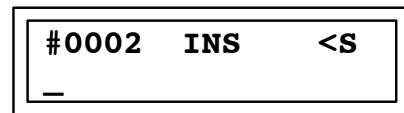

Press the key sequence

    :

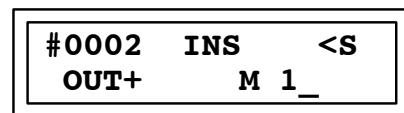

Press the  key:

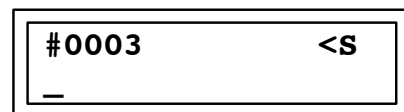

Press the key sequence

LD $\frac{C}{M}{T}$ 1 :

```
#0003  INS  <S
      LD   M 1_
```

Press the  key:

```
#0004  INS  <S
      _
```

Press the key sequence

FUNC 3 8 :

```
#0004  INS  <S
      FUNC 38_ BMOVI
```

Press the  key:

```
#0004  BMOVI <S
      P01 _
```

Press the key sequence

3 2 7 6 7 :

```
#0004  BMOVI <S
      P01 32767_
```

Press the  key:

```
#0004  BMOVI <S
      P02 _
```

Press the key sequence

$\frac{-}{+}$ 3 2 7 6 8 :

```
#0004  BMOVI <S
      P02 -32768
```

Press the  key:

```
#0004  BMOVI <S
      P03 _
```

Press the key sequence 1 :

```
#0004 BMOVI <S
P03 1_
```

Press the ENT
↓ key:

```
#0004 BMOVI <S
P04 _
```

Press the key sequence 2 :

```
#0004 BMOVI <S
P04 2_
```

Press the ENT
↓ key:

```
#0004 BMOVI <S
P05 _
```

Press the key sequence 2 :

```
#0004 BMOVI <S
P05 2_
```

Press the ENT
↓ key:

```
#0004 BMOVI <S
P06 _
```

Press the key sequence 1 :

```
#0004 BMOVI <S
P06 1_
```

Press the ENT
↓ key:

```
#0004 BMOVI <S
P07 _
```

Press the key sequence 1 :

```
#0004 BMOVI <S
P07      1_
```

Press the ENT
↓ key:

```
#0004 BMOVI <S
P08_
```

Press the key sequence R 1 0 :

```
#0004 BMOVI <S
P08      R 10_
```

Press the ENT
↓ key:

```
#0005 INS <S
_
```

Press the key sequence OUT
OUTM -/+ B Q
AQ 1 :

```
#0005 INS <S
OUT+      Q 1_
```

Press the ENT
↓ key:

```
#0006 INS <S
_
```

Block Clear (BLKCL) Function 44

The block clear function (BLKCL) is a conditionally executed function which fills an array of 16-bit words with the constant zero.

When the logic controlling the enable input to the function passes power flow to the enable (EN) input the function is executed by the CPU. During the execution all of the bits in a word or a group of consecutive 16 bit words located at a starting memory location specified by parameter P1 are changed to zeros. If this starting location is for a discrete memory type (%I, %Q, %M, or %T) the transition information associated with the reference is also cleared.

The location of the word or group of words which will have all of their bits changed to zero is specified by parameter P1 which is the memory address location for the first word of the group of consecutive words to be zeroed.

The number of 16 bit words in the consecutive group of words to be cleared is specified by parameter P2 (LEN). The limits of LEN depend on the memory type being used and the starting address of the first word of the group of words to be copied, and the starting address of the final memory location where the words have been cleared. If the length plus the memory address exceed the total number of words for that memory type DATA ERR will be displayed on the screen of the Hand-Held Programmer.

Parameter P1 specifies memory locations representing 16 bit words. If discrete memory types are used for parameters P1 and P2, the beginning address must be on a 16 point boundary. Power flow through this function occurs only when the functions enable input is receiving power flow.

To prevent multiple moves from taking place it is advisable to have the power flow to the enable input be controlled by a contact of a one shot element (OUT+ or OUT-).

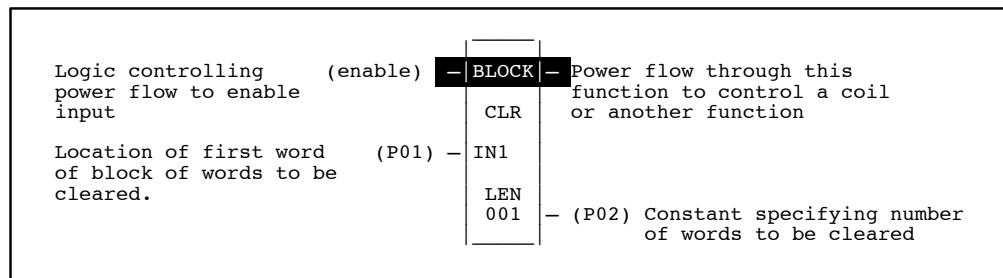

Programming Elements and Sequential Order of Programming

1. Logic controlling the enable input from the left bus. This must start with an LD element.
2. Type of function: Function 44 (BLKCL).
3. Parameter P1 (IN): location of word or group of words that are to have their bits changed to 0 (zero). This is the starting memory location for the first word of the group of words to be zeroed.
4. Parameter P2 (LEN): a constant specifying the number of 16 bit words in the consecutive group of words to be zeroed.

The following table specifies which memory types are valid for each of the BLKCL function parameters:

Allowable Memory Types for BLKCL (Function 44)

Parameter	%I	%Q	%M	%T	%G	%S	%R	%AI	%AQ	Constant
StartIN (P01)	•	•	•	•	•	•†	•	•	•	
Length LEN (P02)										•

† Only %SA, %SB, and %SC are used. %S cannot be used.

Programming Example for BLKCL Function

In this example when input %I0001 is closed (passing power flow to the enable input of the function block) zeros will be moved into the 32 (two 16 Bit words specified by parameter P2) discrete Global memory location beginning at %G0017 specified by parameter P1 and ending at location %G0048 (32 locations from %G0017 to %G0048).

Ladder Diagram Representation

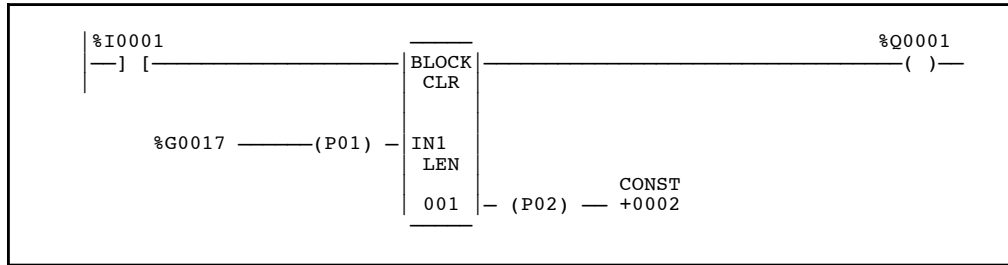

Statement List Representation

```

#0001    LD          %I0001
#0002    FUNC        44      BLKCL
                P1:    %G0017
                P2:    +0002
#0003    OUT          %Q0001
    
```

After pressing INS key: Programming sequence

Key Strokes

HHP Display

Initial display:

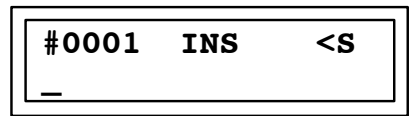

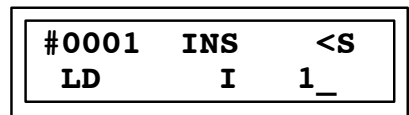
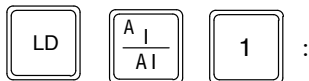

Press the key sequence



Press the  key:

```
#0002  INS  <S
_
```

Press the key sequence

   :

```
#0002  INS  <S
FUNC  44_  BLKCL
```

Press the  key:

```
#0002  BLKCL <S
P01  _
```

Press the key sequence

   :

```
#0002  BLKCL <S
P01  G 17_
```

Press the  key:

```
#0002  BLKCL <S
P02  _
```



Press the key sequence  :

```
#0004  BLKCL <S
P02  2_
```

Press the  key:

```
#0003  INS  <S
_
```

Press the key sequence

   :

```
#0003  INS  <S
OUT  Q 1_
```

Shift Register SHFR (SHFRW) Function 45

The “N” stage word shift register function (SHFRW) is a conditionally executed function which performs a word shift through an array of 16 bit words.

The shift register is a group of sequentially numbered memory storage locations, with each memory location containing a 16 bit word. The number of 16 bit memory storage locations in the sequentially numbered group of storage locations is specified by the constant programmed in P3, the LEN parameter (maximum 512 for a model 311 CPU, 2048 for a model 331 CPU). The address of the first and lowest numbered storage location is specified by parameter P2. The address for the last and highest numbered storage location in the group is equal to the address specified for the first address plus the number of memory locations in the group specified by parameter P3 (LEN) minus one.

To make this group of sequentially numbered memory storage location be a shift register, each time a shift command is received, the contents (16 bit word) of each memory location is moved to the next higher numbered memory location. Thus a 16 bit word starts at the first memory location and on every shift command will move one memory storage location to the next higher numbered memory storage location until it reaches the highest numbered (last) memory storage location in this group of storage locations. When this 16 bit word reaches the last storage area available in this group it is transferred to the storage location specified by parameter P4. The previous contents of the storage location specified by parameter P4 are lost.

The limits of LEN depend on the memory type being used and the starting address of the first word of the group of words in the shift register, and the number of 16 bit words specified by the parameter P3 (LEN). If the length plus the memory address exceed the total number of words for that memory type DATA ERR will be displayed on the screen of the Hand-Held Programmer.

When the logic controlling the enable input to the function passes power flow to the enable (EN) input the function is executed by the CPU and a new shift register function will take place. During the execution of a shift register function all of the bits in the 16 bit word which has the highest memory address of this group of 16 bit words are moved (shifted out) to the 16 bit memory location specified by parameter P4 (Q). After these bits are stored, and during the same execution of this function, the data stored as 16 bit words in each of the other memory locations in this group of memory location is moved (shifted), one 16 bit word at a time, to the next higher 16 bit memory location. The bits stored in the 16 bit word whose location is specified by parameter P1 is moved into the lowest 16 bit memory location of this group (this is also the starting location of the group specified by parameter P2) which was left vacant when the above shift of words took place.

When the logic controlling the reset input (R) to this function passes power flow to the reset (R) input a reset to this function will take place. During a reset all of the bits in all the memory locations within this group of words are set to zero, starting at the lowest address specified by parameter P2 and ending at the highest address which is an address equal the address specified by parameter P2 plus the number of addresses specified by the LEN constant parameter P3 minus one. The bits stored in the memory location specified by parameter P4 (Q) and parameter P1 (IN) are not changed by the reset of this function.

Power flow to the reset input is dominant over power flow to the enable input. That is if power flow is received at both the enable and the rest input at the same time; no shift or move of memory contents will take place and all of the 16 bit of each word in every memory location from the lowest to the highest location in the group of memory locations will be set to zero.

Power flow through this function will follow the condition of the enable input. Parameters P1, P2, and P4 are memory locations representing 16 bit words.

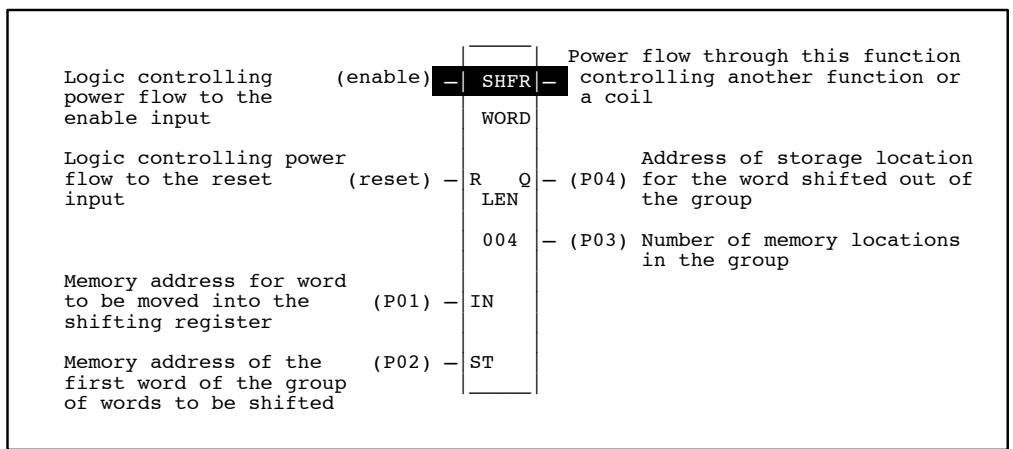
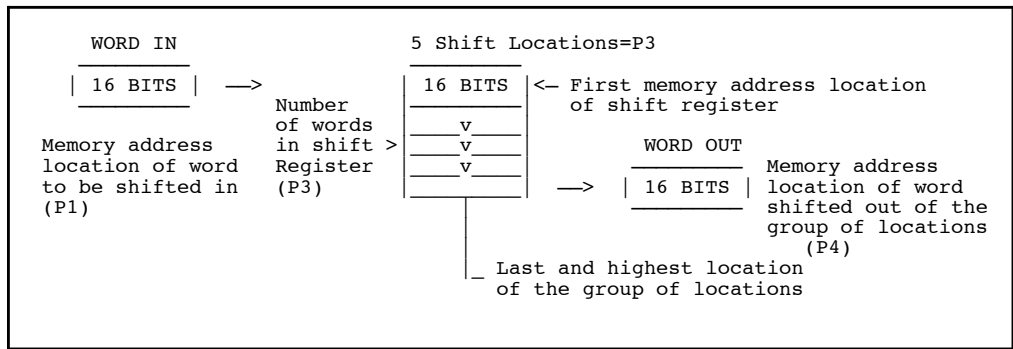

Programming Elements and Sequential Order of Programming

1. Logic controlling the enable input from the left bus. This must start with an LD element.
2. Logic controlling the reset input from the left bus. This must start with an LD element.
3. Type of function: Function 45 (SHFRW).
4. Parameter P1 (IN): the address for the memory location which contains the 16 bit word which is to be moved into the memory location left vacant when the word shift took place.
5. Parameter P2 (ST): the memory address location for the first memory location of the group of memory locations containing the words to be shifted.
6. Parameter P3 (LEN): a constant specifying the number of memory locations in the group of memory locations making up the shift register.
7. Parameter P4 (Q): the memory address location where the 16 bit word which was moved out of the group of 16 bit memory locations is to be stored.

The following table specifies which memory types are valid for each of the SHFRW parameters:

Allowable Memory Types for SHFRW (Function 45)

Parameter	%I	%Q	%M	%T	%G	%S	%R	%AI	%AQ	Constant
Input IN (P01)	•	•	•	•	•	•	•	•	•	•
Location ST (P02)	•	•	•	•	•	•†	•	•	•	
Length LEN (P03)										•
Output Q (P04)	•	•	•	•	•	•†	•	•	•	

† Only %SA, %SB, and %SC are used. %S cannot be used.

Programming Example for SHFR Function

In the following example when input %I0001 is closed (passing power flow to the enable input) and when a SHFR function is executed the bits in the 16 bit word which has the highest memory address of the group (%R0014) of 16 bit words is copied into the 16 bit memory location of %R0060 specified by parameter P4. After the bits are stored the data stored as bits in each of the other words, specified by registers %R0011, %R0012, %R0013 automatically remove one 16 bit word at a time starting with %R0013. %R0013 moves to %R0014, %R0012 moves to %R0013 and %R0011 moves to %R0012. Also the 16 Bit word in P1 specified by %R0001 is copied into %R0011.

After the Shift has been completed, a reset operation takes place. All of the 16 bit words stored in Registers (%R011 to %R0014) specified by parameter P2 and set to zero, however registers %R0001 and %R0060 specified by parameters P1 and P4 respectively remain unchanged:

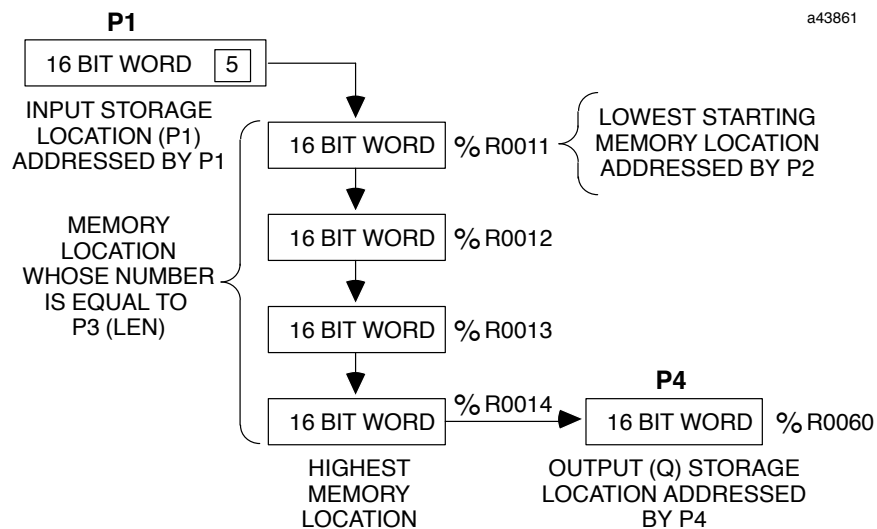

a43861

Assume that decimal numbers in the registers are as follows.

	Before Shift (→)	After Shift	After Reset
%R0001	5	5	5
%R0011	20	5	0
%R0012	25	20	0
%R0013	4	25	0
%R0014	100	4	0
%R0060	0	100	100

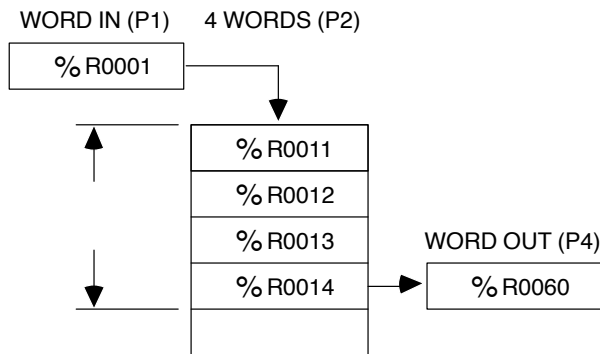

Ladder Diagram Representation

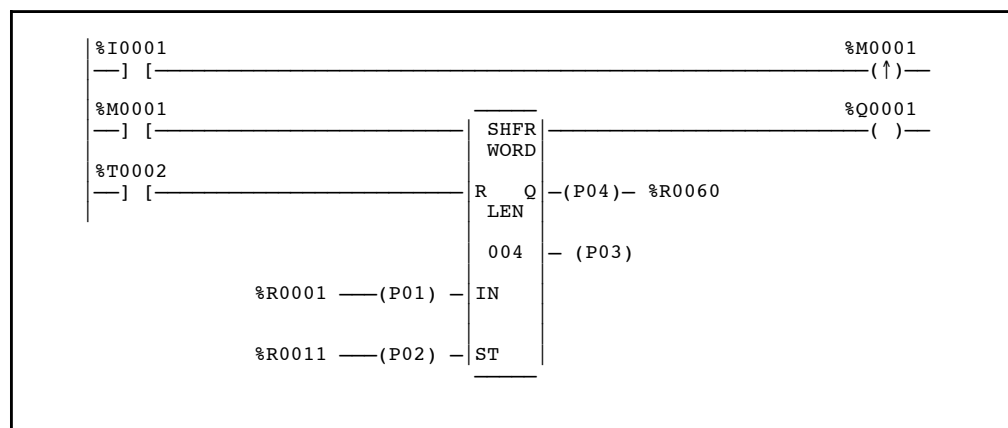

Statement List Representation

```

#0001: LD %I0001
#0002: OUT+ %M0001
#0003: LD %M0001
#0004: LD %T0002
#0005: FUNC 45 SHFRW
      P1: %R0001
      P2: %R0011
      P3: 4
      P4: %R0060
#0006: OUT %Q0001
    
```

After pressing  key: Programming sequence



Key Strokes

HHP Display

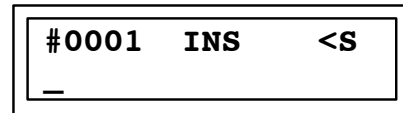
Initial display:



Press the key sequence



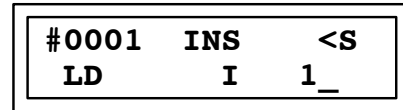

   :

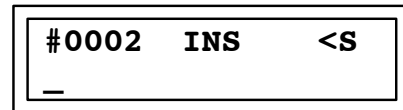

Press the  key:



Press the key sequence

    :

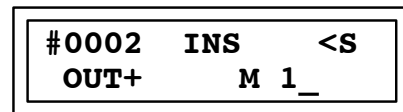

Press the  key:

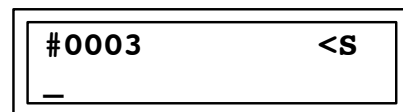

Press the key sequence

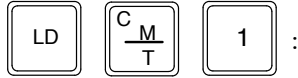

```
#0003  INS  <S  
LD      M 1_
```

Press the  key:

```
#0004  INS  <S  
_
```

Press the key sequence

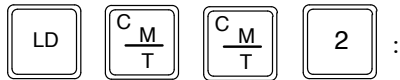

```
#0004  INS  <S  
LD      T 2_
```

Press the  key:

```
#0005  INS  <S  
_
```

Press the key sequence



```
#0005  INS  <S  
FUNC 45_  SHFRW
```

Press the  key:

```
#0005  SHFRW <S  
P01  _
```

Press the key sequence   :

```
#0005  SHFRW <S  
P01      R 1_
```

Press the  key:

```
#0005  SHFRW <S  
P02  _
```

Press the key sequence

R **1** **1** :

```
#0005 SHFRW <S  
P02 R 11_
```

Press the **ENT** key:

```
#0005 SHFRW <S  
P03 _
```

Press the key sequence **4** :

```
#0005 SHFRW <S  
P03 4_
```

Press the **ENT** key:

```
#0005 SHFRW <S  
P04 _
```

Press the key sequence

R **6** **0** :

```
#0005 SHFRW <S  
P04 R 60_
```

Press the **ENT** key:

```
#0006 INS <S  
_
```

Press the key sequence

OUT **BQ** **1** :
OUTM **AQ**

```
#0006 INS <S  
OUT Q 1_
```

Press the **ENT** key:

```
#0007 INS <S  
_
```

Shift Register Bit (SHFRB) Function 46

The Shift Register Bit function (SHFRB) is a conditionally executed function which is used to implement a shift register that will shift a specified bit.

When the logic controlling the enable input to the function passes power flow to the enable (EN) input, the function is executed by the CPU and a new shift register bit function will take place. When the reset (R) input is a 1 all bits in the shift register are set to 0. The bits specified by IN and Q are not changed during the reset. The power flow output is a 1 whenever the function executes.

The Shift Register Bit function implements a shift register on the bit level. The IN parameter specifies the bit to be shifted into the shift register. The ST parameter specifies the starting address of the shift register. The LEN parameter specifies the length of the shift register in bits. The Q parameter specifies the destination of the bit that is shifted out of the shift register.

Any discrete or word reference can be specified for IN, ST, and Q within the parameter restrictions stated below. Since ST is not restricted to a word or byte boundary and LEN is in bits it is possible to define a shift register that does not occupy an entire byte or word. The unused bits in the byte or word are not affected by the execution of the function.

If a word reference is specified for IN or Q it is assumed that the least significant bit of the word specified by IN or Q is the bit to be used. If a word reference is specified for ST it is assumed that the beginning of the shift register is the least significant bit of the word specified by ST.

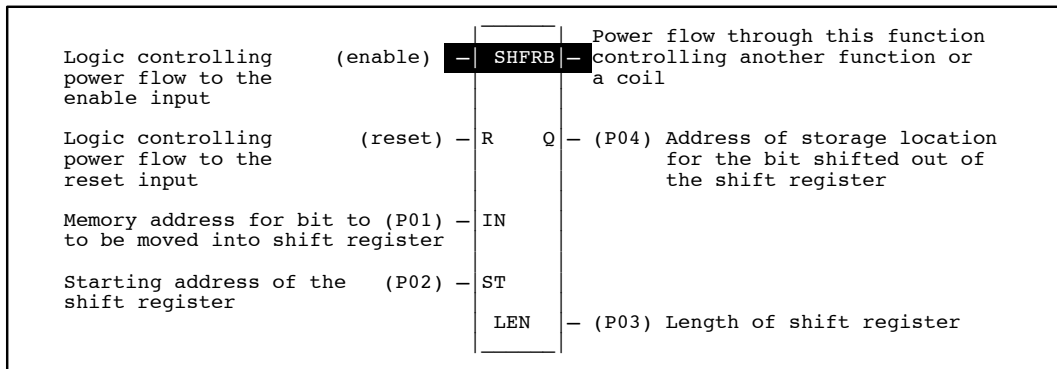

Programming Elements and Sequential Order of Programming

1. Logic controlling the enable input from the left bus. This must start with an LD element.
2. Logic controlling the reset input from the left bus. This must start with an LD element.
3. Type of function: Function 46 (SHFRW).
4. Parameter P1 (IN): the address for the memory location which contains the bit which is to be moved into the shift register.
5. Parameter P2 (ST): the memory address location for the first memory location of shift register.

6. Parameter P3 (LEN): a constant specifying the length of the shift register in bits.
7. Parameter P4 (Q): the memory address location where the bit which was moved out of the shift register is to be stored.

The following table specifies which memory types are valid for each of the SHFRB function parameters:

Allowable Memory Types for SHFRB (Function 46)

Parameter	%I	%Q	%M	%T	%S	%SA	%SB	%SC	%G	%R	%AI	%AQ	Constant
IN	•	•	•	•	•	•	•	•	•	•	•	•	•
ST	•	•	•	•		•	•	•	•	•	•	•	
LEN†													•
Q	•	•	•	•		•	•	•	•	•	•	•	

† LEN is between 1 and 256. The ending address determined by ST and LEN must not cross reference table boundaries

Programming Example for SHFRB Function

In this example the bit string starting with %I0012, specified by parameter P1, is shifted into the shift register %G0021 to %G0024, specified by parameter P2. The most significant bit, %G0024 is shifted out of the shift register to the reference %Q0123, specified by parameter P4.

Ladder Diagram Representation

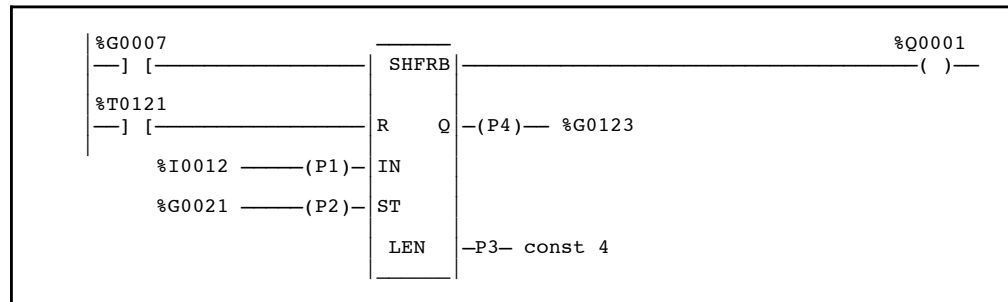

Statement List Representation

```

#0001    LD                %G0007
#0002    LD                %T0121
#0003    FUNC              46    SHFRB
                                P1:  %I0012
                                P2:  %G0021
                                P3:   4
                                P4:  %Q0123
#0004    OUT               %Q0001
    
```

After pressing  key: Programming sequence



Key Strokes

HHP Display

Initial display:

```
#0001  INS  <S
_
```

Press the key sequence







   :

```
#0001  INS  <S
LD      G 7_
```

Press the  key:

```
#0002  INS  <S
_
```

Press the key sequence

      :

```
#0002  INS  <S
LD      T 121_
```

Press the  key:

```
#0003  INS  <S
_
```

Press the key sequence

   :

```
#0003  INS  <S
FUNC 46  SHFRB
```

Press the  key:

```
#0003  SHFRB <S
P01  _
```

Press the key sequence

   :

```
#0003  SHFRB <S
P01    I12_
```

Press the key sequence

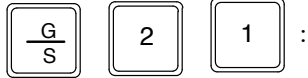

```
#0003 SHFRB <S  
P02 G21_
```

Press the  key:

```
#0003 SHFRB <S  
P03 _
```

Press the key sequence  :

```
#0003 SHFRB <S  
P03 4_
```

Press the  key:

```
#0003 SHFRB <S  
P04 _
```

Press the key sequence



```
#0003 SHFEB <S  
P04 Q123
```

Press the  key:

```
#0004 INS <S  
_
```

Press the key sequence

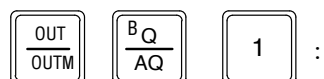

```
#0004 INS <S  
OUT Q 1_
```

Press the  key:

```
#0005 INS <S  
_
```

Stage Bit Sequencer (SEQB) Function 47

The "N" stage bit sequencer function (SEQB) is a conditionally executed function which performs a bit sequence shift through an array of bits.

The stage bit sequencer is a group of sequentially numbered memory locations with each location one bit long. The number of bits in the group is its length which is specified by parameter P3 (LEN). The memory address location of the first bit of this group, which is the starting address of the group of bits, is specified by parameter P2. Beginning at the starting address each bit is assigned a number by the CPU. The numbers start at one for the first bit located at the starting address and increment sequentially to the maximum number of bits in the group, which is the length number specified by parameter P3. Each of these locations is called a step and the number given by the CPU to each of the single bit memory locations is called the step number. This stage bit sequencer also has a pointer, which is an indicating device that points to the step number.

Each location in this group of bits can have a 1 (one) to represent an ON condition (power flow) or a 0 (zero) to represent an off condition (no power flow) stored in it. The location or step indicated by the pointer is the only location or step in the group that has a one (indicates an on condition) stored in it. All other locations or steps have a zero (indicates an off condition) stored in it. Memory locations in this group of memory locations that have had their bit set to a one by other logic, since this stage bit sequencer has been reset, will not be affected and will also be set to a one. If the group of bits making up the bit shift sequencer are stored in discrete memory locations such as %Q, %M, %T, and %G contacts may be taken off of these points and used in the relay logic to control coils or functions.

When the logic controlling the enable input to this function changes from a condition of passing no power flow to a condition of passing power flow to this functions enable (EN) input and when the logic step where this function is stored in programmed memory is executed by the CPU, one execution of this stage bit sequencer function will take place. During the execution of a stage bit sequencer function the pointer will move from the step it is presently pointing to the next higher numbered step or next lower numbered step. The direction that the pointer will move is determined by the condition of the logic controlling the DIR input. When the logic at the DIR input is passing power flow to the DIR input the pointer will increment to the next higher step number. If the logic at the DIR input is not passing power flow to the DIR input the pointer will decrement to the next lower step number.

When the pointer is at the highest numbered step of the group and is told to increment it will move to the beginning step number (lowest step number) which is step number one. Also if the pointer is located at step number one (the lowest step number of the group) and is told to decrement it will move to the highest step number of the group.

When the logic controlling the reset input to this function passes power flow to this functions reset (RST) input and each time the logic step where this function is stored in programmed memory is executed by the CPU the pointer will move to the step number specified by parameter P1 (STEP), which may be a constant or a number located in the 16 bit memory location specified by parameter P1. Also all memory locations of the stage bit sequencer (except the new pointer location) and the remaining memory locations to the next 16 bit boundary will be set to a zero. If a minus one (-1) or zero (0) is programmed in as parameter P1, it will signify no parameter and the pointer will be moved to step number one, while setting as above the bits in the other steps and the remaining memory locations to the next 16 point boundary to a zero (0).

The constant specified by parameter P1, or the value located in the 16 bit memory location specified by parameter P1 should not be allowed to be larger then the number of steps specified by parameter P3 in this stage bit sequencer. If the step number is larger then the number of steps in the stage bit sequencer, upon power flow to the reset input, a one (1) will be placed into the single bit memory location equal to the equivalent step number. The next execution of the stage bit sequencer will move the pointer to step number one if incrementing and to the highest numbered step when decrementing.

Power flow to the reset input is dominant over the enable input. That is if power flow is received at both the enable input and the reset input at the same time; the pointer will move to the step number specified by parameter P1. Power flow through this function will follow the condition of the logic connected to the enable input of this function.

When parameters P1 and P2 are memory locations they represent 16 bit words. If discrete memory types are used for parameters P1, and P2 the beginning address must be on a 16 point boundary.

The enable (EN) input is interpreted differently depending on the state it was in the *previous* time the bit sequencer function block was executed. The reset (R) input dominates over the enable input, as shown in the following table:

R Current Execution	EN Previous Execution	EN Current Execution	Bit Sequencer Execution
False	False	False	Bit sequencer does not execute.
False	False	True	Bitsequencerincrements/decrementsby1.
False	True	False	Bit sequencer does not execute.
False	True	True	Bit sequencer does not execute.
True	False	False	Bit sequencer reset.
True	False	True	Bit sequencer reset.
True	True	False	Bit sequencer reset.
True	True	True	Bit sequencer reset.

The stage bit sequencer has operating values as well as programming parameters. One of the operating values has the same value as a programming parameter. The operating values are:

- **CURRENT STEP:** The number of the step where the pointer is currently located.
- **NUMBER OF STEPS:** How many steps or single bit memory locations there are in the group of single bit memory locations making up the stage bit sequencer. This value is also a programming parameter.
- **CONTROL WORD:** This is the information used by the CPU to control this function

These values are located in and occupy three sequentially numbered register locations in the register memory. The lowest numbered register of the three is the defining location for this stage bit sequencer. The address for this register must be on a three register boundary. Thus, if you subtract one from this register number (the lowest of the three sequential registers) the new number must be divisible by three, i.e. the registers must be grouped as follows; R1 ____, R4 ____, R7 ____, R10 ____ etc.

Table 9-6. Operating Registers and Register Locations

Sequencer Location:	Current Step	Register number programmed as P4
Sequencer Location + 1:	Number of Steps	
Sequencer Location + 2:	Control Information	

This stage bit sequencer location register is the register number which is programmed as parameter P4. The data found in this register is the current step number that the pointer is pointing to (the current location of the pointer). The number of steps in the bit sequencer can be found in the second of the three consecutive registers, which is programmed as parameter P3. The third register of the three consecutively numbered registers has the control word stored in it.

Caution

Do not write to sequencer location + 2. Changing the data in the control information word may result in unexpected operation of the PLC.

When programming the parameter data for a stage bit sequencer note that parameter P3, which specifies the number of steps with in the stage bit sequencer, is a constant value and is also automatically placed by the CPU into the second register of the three sequential operating value registers.

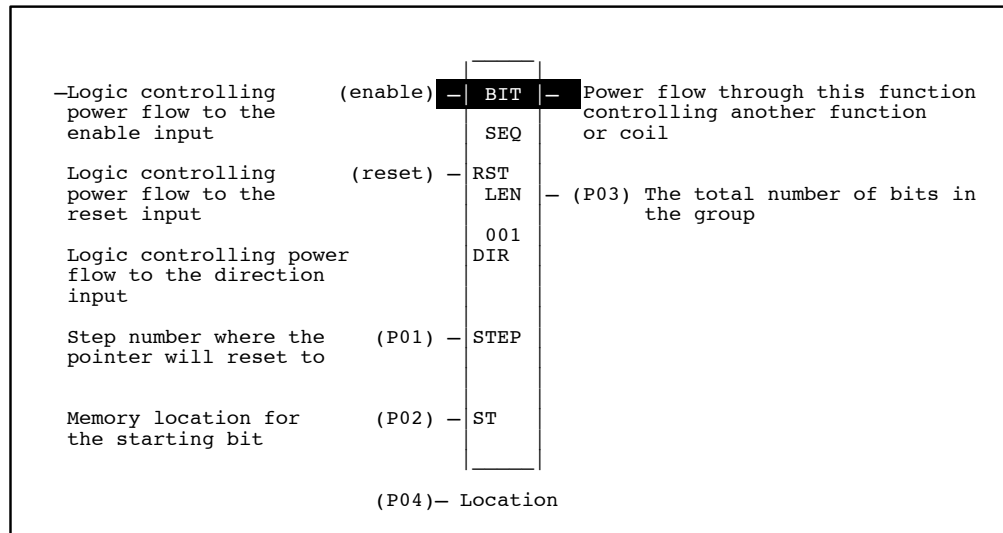

Programming Elements and Sequential Order of Programming

1. Logic controlling the enable input from the left bus. This logic must start with an LD element.
2. Logic controlling the reset input from the left bus. This logic must start with an LD element.
3. Logic controlling the direction input from the left bus. This logic must start with an LD element.

4. Parameter P1 (STEP): the number of the step that the pointer is to go to when power flow is received at the reset input. This can be a constant value or a memory address location where the value is stored.
5. Parameter P2 (STRT): starting memory address where the stage bit sequencer is stored in memory (address which contains the first step of the stage bit sequencer).
6. Parameter P3 (LEN): a constant value specifying the number of steps in the stage bit sequencer.
7. Parameter P4 (LOC): the number of the first register of the three sequential registers containing the operating values.

The following table specifies which memory types are valid for each of the SEQB function parameters:

Allowable Memory Types for SEQB (Function 47)

Parameter	%I	%Q	%M	%T	%G	%S	%R	%AI	%AQ	Constant
STEP(P01)	•	•	•	•	•	•	•	•	•	•†
StartSTRT (P02)	•	•	•	•	•		•	•		•‡
LEN(P03)										•
Location(P04)							•			

† Only positive constants are allowed, except -1 which indicates no step parameter.

‡ Only constant -1, which indicates no STRT parameter.

P1 = Reset step number for the pointer to move to

P2 = Memory address location for the group of bits

P3 = Number of bit (steps) within the group

P4 = Lowest numbered register of the three sequentially numbered control registers

Programming Example for SEQB Function

In this example there are 14 memory locations specified by parameter P3, which are memory location %Q0017 through %Q0032 specified by parameter P2 in the stage bit sequencer. The pointer will move to step 12 specified by parameter P1 when %I0002 is on, passing power flow to the reset input. The pointer will increment through the step numbers if %I0003 is on and decrement through the step numbers if %I0003 is off.

The operating values are stored in registers %R0001, %R0002 and %R0003 as specified by parameter P4.

Memory locations not in the stage bit sequencer but are in the 16 point boundary are affected by the reset execution

Pointer location
↓

Step Number																		
		14	13	12	11	10	9	8	7	6	5	4	3	2	1			
Before execution	1	1	0	0	0	0	0	0	0	0	1	0	0	0	0	0		
Memory Location	33	32	31	30	29	28	27	26	25	24	23	22	21	20	19	18	17	%Q

Pointer location
↓

Step Number																		
		14	13	12	11	10	9	8	7	6	5	4	3	2	1			
After execution I3 ON	1	1	0	0	0	0	0	0	0	1	0	0	0	0	0	0	0	
Incrementing Memory Location	33	32	31	30	29	28	27	26	25	24	23	22	21	20	19	18	17	%Q

Pointer location
↓

Step Number																		
		14	13	12	11	10	9	8	7	6	5	4	3	2	1			
I2 ON After Reset	1	0	0	0	0	1	0	0	0	0	0	0	0	0	0	0	0	
Memory Location	33	32	31	30	29	28	27	26	25	24	23	22	21	20	19	18	17	%Q

- Pointer will increment (I3 on Passing Power Flow) to step 14 (memory location Q30) and return to step 1 (memory location Q17) on the next execution.
- Pointer will decrement (I3 OFF no power flow) to step 1 (memory location Q17) then on the next execution will move to step 14 (memory location Q30)
- Upon reset (I2 on passing power flow) memory locations 17 through 32 are set to zero except 28 (step 12), the reset step location which is set to a one. Memory location 33 is unaffected because it is not within the group bits of the 16 bit word boundary of Q17.

Ladder Diagram Representation

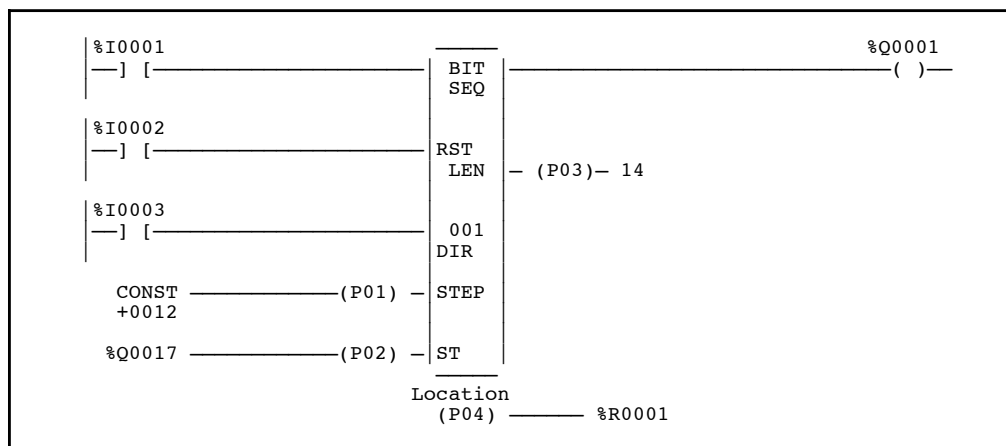

Statement List Representation:

```

#0001: LD %I0001
#0002: LD %I0002
#0003: LD %I0003
#0004: FUNC 47 SEQB
      P1: 12
      P2: %Q0017
      P3: 14
      P4: %R0001
#0005: OUT %Q0001

```

After pressing  key: Programming sequence

Key Strokes

HHP Display



Initial display:

```

#0001  INS  <S
_

```

Press the key sequence

   :

```

#0001  INS  <S
LD      I 1_

```



Press the  key:

```

#0002  INS  <S
_

```

Press the key sequence

   :

```

#0002  INS  <S
LD      I 2_

```

Press the  key:

```

#0003  INS  <S
_

```

Press the key sequence

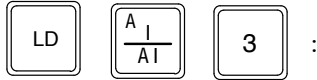

```
#0003  INS  <S  
LD      I 3_
```

Press the  key:

```
#0004  INS  <S  
_
```

Press the key sequence



```
#0004  INS  <S  
FUNC  47_ SEQB
```

Press the  key:

```
#0004  SEQB <S  
P01  _
```

Press the key sequence   :

```
#0004  SEQB <S  
P01  I2_
```

Press the  key:

```
#0004  SEQB <S  
P02  _
```

Press the key sequence



```
#0004  SEQB <S  
P02  Q 17_
```

Press the  key:

```
#0004  SEQB <S  
P03  _
```

Press the key sequence

1 **4** :

```
#0003 SRQB <S  
P03 14
```

Press the  key:

```
#0004 SEQB <S  
P04 _
```



Press the key sequence **R** **1** :

```
#0003 SEQB <S  
P04 R 1_
```

Press the  key:

```
#0005 INS <S  
_
```

Press the key sequence

  **1** :

```
#0005 INS <S  
OUT Q 1_
```

Press the  key:

```
#0006 INS <S  
_
```

Communications Request (COMMREQ) Function 88

The communications request function (COMMREQ) is a conditionally executed function which allows the program to communicate with an intelligent module, such as a Programmable Coprocessor Module, in the system. The information presented here shows the format of a COMMREQ function. Additional information is required in order to program the COMMREQ for each type of device. This information can be found with the documentation for each intelligent module.

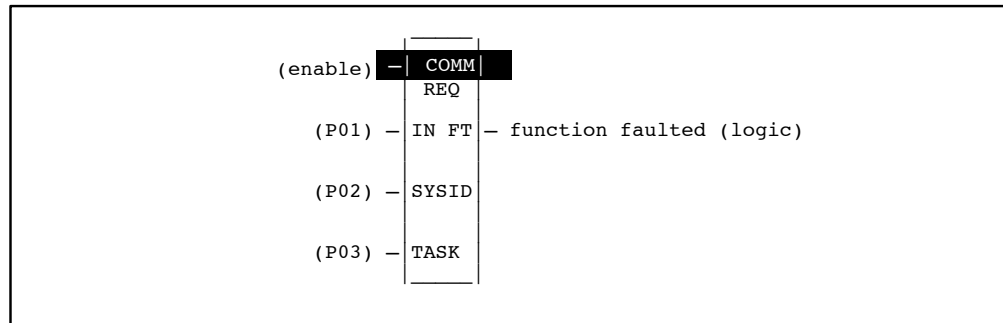

When the COMMREQ function receives power flow to the enable input, a command block of data is sent to the communications TASK as specified in parameter P3. The command block begins at the reference specified by the parameter IN (P1). The device to be communicated with is indicated by entering its rack and slot number for SYSID as specified in parameter P2. (For additional information on command blocks, please refer to the documentation supplied with your intelligent module).

The communications request may either send a message and wait for a reply, or send a message and continue without waiting for a reply. If a reply is requested, a timeout period is used to resume program execution if the requested device does not respond.

If the command block specifies that the program will not wait for a reply, the command block contents are sent to the receiving device and the program execution resumes immediately. The timeout value is ignored. The FT output is set to 0 (false).

If the command block specifies that the program will wait for a reply, the command block contents are sent to the receiving device and the CPU waits for a reply. The maximum length of time the PLC will wait for the device to respond is specified in the command block. If the device does not respond in that time, program execution resumes. The FT output is set to 1 (true).

The following table specifies which memory types are valid for each of the COMMREQ function parameters:

Allowable Memory Types for COMMREQ (Function 88)

Parameter	%I	%Q	%M	%T	%G	%S	%R	%AI	%AQ	Constant
Command CMD (P01)							•	•	•	
SYSID (P02)	•	•	•	•			•	•	•	•
TASK (P03)							•	•	•	•

Programming Example for COMMREQ Function

In the following example, when enabling input %I0020 is closed, a command block located starting at %R0016 is sent to communications task 1 in the device located at rack 1, slot 2 of the PLC. If an error occurs, %Q00100 is set.

Ladder Diagram Representation

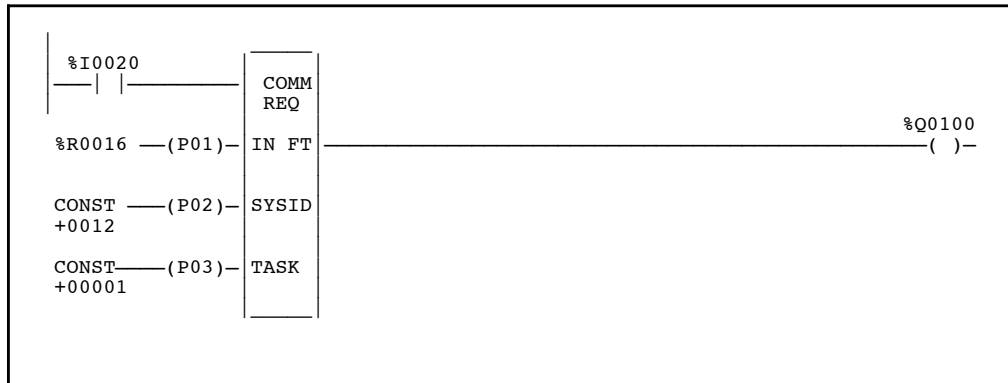

Statement List Representation

```

#0001: LD          %I0020
#0002: FUNC      88  COMMREQ
          P1:    %R0016
          P2:    12
          P3:    1
#0003: OUT          %Q0100
    
```

After pressing INS key: Programming sequence

Key Strokes

HHP Display

Initial display:

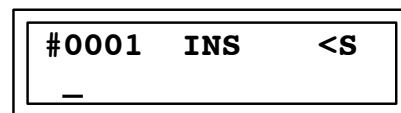

Press the key sequence

LD  2 0 :

```
#0001  INS  <S
LD      I 20_
```

Press the  key:

```
#0002  INS  <S
_
```

Press the key sequence

FUNC   :

```
#0002  INS  <S
FUNC   88_ COMRQ
```

Press the  key:

```
#0002  COMRQ <S
P01  _
```

Press the key sequence

R   :

```
#0002  COMRQ <S
P01    R 16_
```

Press the  key:

```
#0002  COMRQ <S
P02  _
```

Press the key sequence   :

```
#0002  COMRQ <S
P02    12_
```

Press the  key:

```
#0002  COMRQ <S
P03  _
```

Press the key sequence 1 :

```
#0002  COMRQ  <S  
P03      1_
```

Press the ENT
↓ key:

```
#0003  INS    <S  
_
```

Press the key sequence OUT
OUTM BQ
AQ 1 0 0 :

```
#0003  INS    <S  
OUT      Q 100_
```

Press the ENT
↓ key:

```
#0004  INS    <S  
_
```

Section 6: Conversion Functions

Conversion functions are used to convert a data item from one number type to another. The conversion functions for the Series 90-30/90-20 PLCs are listed in the following table.

Abbreviation	Function	Description
Integer to BCD	BCD	Convert an integer value to a 4-digit BCD value.
BCD to Integer	INT	Convert a 4-digit BCD value to an integer value.

Descriptions of each of these functions are included in this section.

Integer to BCD Conversion (BCD) Function 80

The integer to BCD conversion function (BCD) is a conditionally executed function which converts an integer value to a 4-digit BCD value. This function is typically used to prepare CPU data for display on external BCD-compatible devices.

When the logic controlling the enable input to this function passes power flow to the functions enable input the function is executed by the CPU and a new integer to BCD conversion function will take place. During the execution of an integer to BCD conversion, the decimal equivalent of the 16 bits stored in the memory location specified by parameter P1 that are in the decimal range of 0000 through 9999 are split into four single digit decimal numbers. Each of these single digit decimal numbers is converted into its equivalent four bit BCD (binary coded decimal) number. The four bits of each of the BCD numbers equal to each of the single decimal digits is stored in the memory location specified by parameter P2. The BCD digit representing the LSD (Least Significant Digit) of the decimal digits is stored in the lowest four memory locations specified by parameter P2.

When the decimal numbers to be converted are in the range of positive decimal numbers from 0000 to 9999 and the enable input to this function is receiving power flow, power flow will pass through this function to another function or a coil. If the decimal numbers to be converted are not in the range of decimal numbers 0000 to 9999 and the number is positive the decimal representation of the bits that will be stored in the memory location specified by parameter P2 will be -26215 which is also 9999 Hexadecimal. The value stored in the memory location specified by parameter P2 will be Zero if the decimal number to be converted is negative.

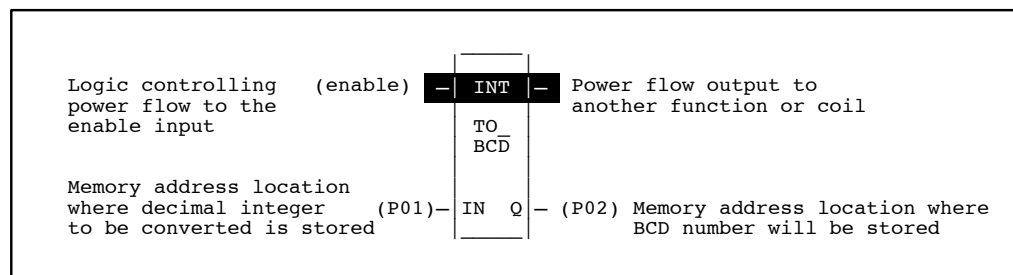

Programming Elements and Sequential Order of Programming

1. Logic controlling the enable input from the left bus. This logic must start with an LD element.
2. Function type: Function 80.
3. Parameter P1 (IN): the memory location where the decimal number to be converted is stored.
4. Parameter P2 (Q): the memory location where the BCD results of the conversion are stored.

The following table specifies which memory types are valid for each of the BCD function parameters:

Allowable Memory Types for BCD (Function 80)

Parameter	%I	%Q	%M	%T	%G	%S	%R	%AI	%AQ	Constant
IN(P01)	•	•	•	•	•		•	•	•	
Q(P02)	•	•	•	•	•		•	•	•	

Programming Example for INT to BCD Function

In this example the decimal equivalent of the 16 bits stored in memory address location %R0001 specified by P1 is converted to its BCD equivalent bits which are stored in memory address location %R0002 as specified by P2.

Assume that the following binary representation of the decimal number 4826 is stored in register %R0001:

0	0	0	1	0	0	1	0	1	1	0	1	1	0	1	0
---	---	---	---	---	---	---	---	---	---	---	---	---	---	---	---

Then the following bits will be in register %R0002 after execution of this function.

0	1	0	0	1	0	0	0	0	0	1	0	0	1	1	0
---	---	---	---	---	---	---	---	---	---	---	---	---	---	---	---

4826 Hexadecimal

Ladder Diagram Representation

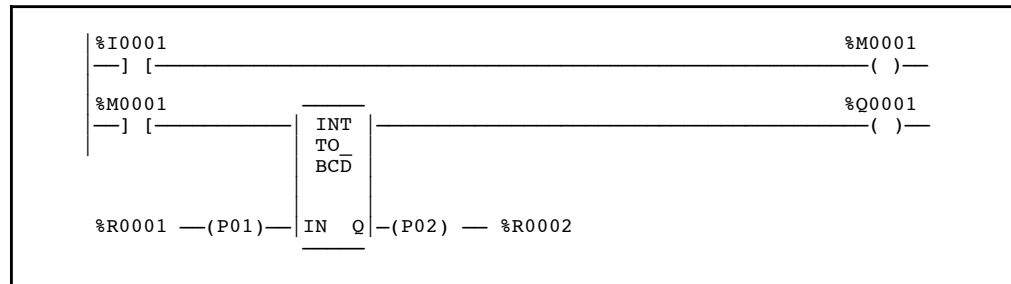

Statement List Representation

```

#0001    LD          %I0001
#0002    OUT+        %M0001
#0003    LD          %M0001
#0004    FUNC        80      BCD
                        P1:   %R0001
                        P2:   %R0002
#0005    OUT          %Q0001
    
```

After pressing  key: Programming sequence



Key Strokes

HHP Display

Initial display:

```
#0001  INS  <S  
_
```

Press the key sequence





   :

```
#0001  INS  <S  
LD      I 1_
```

Press the  key:

```
#0002  INS  <S  
_
```

Press the key sequence



    :

```
#0002  INS  <S  
OUT+   M 1_
```

Press the  key:

```
#0003  INS  <S  
_
```

Press the key sequence

   :

```
#0003  INS  <S  
LD      M 1_
```

Press the  key:

```
#0004  INS  <S  
_
```

Press the key sequence



```
#0004  INS  <S
FUNC  80_ BCD
```

Press the



key:

```
#0004  BCD  <S
P01  _
```

Press the key sequence



```
#0004  BCD  <S
P01      R 1_
```

Press the



key:

```
#0004  BCD  <S
P02  _
```

Press the key sequence



```
#0004  BCD  <S
P02      R 2_
```

Press the



key:

```
#0005  INS  <S
_
```

Press the key sequence

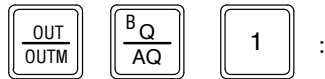

```
#0005  INS  <S
OUT      Q 1_
```

Press the



key:

```
#0006  INS  <S
_
```

BCD to Integer Conversion (INT) Function 81

The BCD to integer conversion function (INT) is a conditionally executed function which converts a 4-digit BCD value to an integer value. This function is typically used to read data from a BCD format device, such as a thumbwheel, and make the data usable by the CPU.

When the logic controlling the enable input to this function passes power flow to the function's enable input the function is executed and a new BCD to integer conversion function will take place. During the execution of a BCD to Integer conversion the 16 bits stored in the memory location specified by parameter P1 are split into four groups. Each group contains four bits which represent one BCD (binary coded decimal) number. The LSB (Least Significant Bit) being the lowest discrete memory location or the first bit of a 16 bit memory location specified by parameter P1. Each of the four bit BCD numbers will be converted into a single digit decimal number from 0 through 9. The total 16 bit word is thus converted into a decimal number four digits long. The binary representation (not BCD) of this decimal number is stored in the memory location specified by parameter P2.

When each of the four BCD numbers converts to a single decimal number from 0 through 9 and the enable input to this function is receiving power flow, power flow will pass through this function to another function or a coil. If any of the BCD numbers converts to a decimal value from 10 through 15 the value stored in the location specified by parameter P2 will be the binary representation of the decimal number -32768 which is also 8000 Hexadecimal.

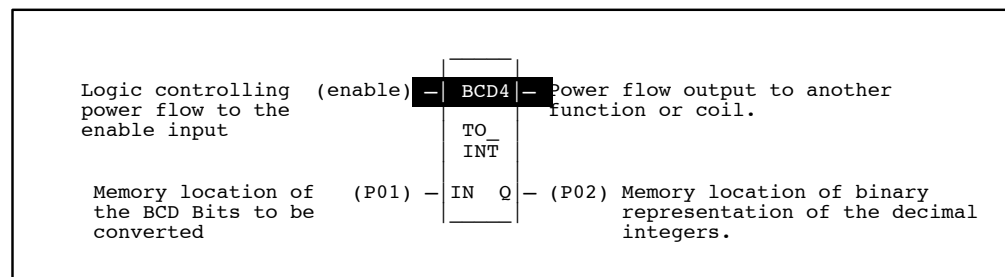

Programming Elements and Sequential Order of Programming

1. Logic controlling the enable input from the left bus. This logic must start with an LD element.
2. Function type: Function 81.
3. Parameter P1 (IN): the memory location where the BCD number to be converted is stored.
4. Parameter P2 (Q): the memory location where the binary representation of the decimal integers are to be stored.

The following table specifies which memory types are valid for each of the INT function parameters:

Allowable Memory Types for INT (Function 81)

Parameter	%I	%Q	%M	%T	%G	%S	%R	%AI	%AQ	Constant
IN(P01)	•	•	•	•	•		•	•	•	
Q(P02)	•	•	•	•	•		•	•	•	

Programming Example for BCD to INT Function

In this example the 16 bits stored in register %R0001 specified by parameter P1 are split into four BCD digits that will each be converted to a decimal number whose binary representation will be stored in register %R0002 specified by parameter P2.

If the following Binary Bits are in Register %R0001:

0 1 0 0 1 0 0 0 0 0 1 0 0 1 1 0 = 4826 Hexadecimal

Then the following Binary bits will be stored in %R0002 after the conversion

0 0 0 1 0 0 1 0 1 1 0 1 1 0 1 0 Binary representation of decimal number 4826 which is hexadecimal12DA.

Ladder Diagram Representation

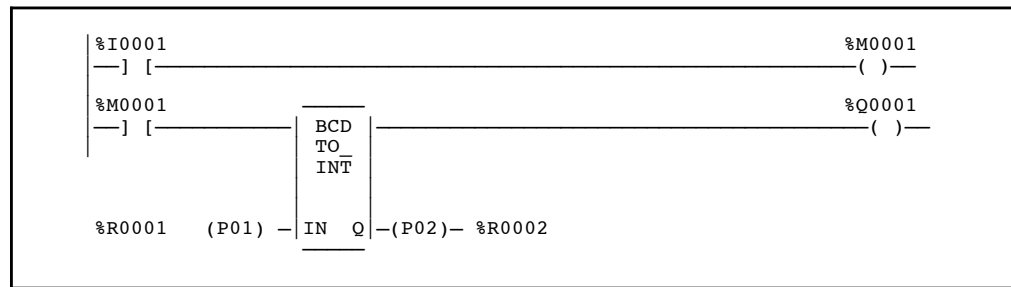

Statement List Representation

```

#0001 LD %I0001
#0002 OUT+ %M0001
#0003 LD %M0001
#0004 FUNC 81 INT
      P1: %R0001
      P2: %R0002
#0005 OUT %Q0001
    
```

After pressing  key: Programming sequence



Key Strokes

HHP Display

Initial display:

```
#0001  INS  <S  
_
```

Press the key sequence



   :

```
#0001  INS  <S  
LD      I 1_
```

Press the  key:

```
#0002  INS  <S  
_
```

Press the key sequence



   :

```
#0002  INS  <S  
OUT+   M 1_
```

Press the  key:

```
#0003  INS  <S  
_
```

Press the key sequence

   :

```
#0003  INS  <S  
LD      M 1_
```

Press the  key:

```
#0004  INS  <S  
_
```

Press the key sequence



```
#0004  INS  <S
FUNC  81_ INT
```

Press the  key:

```
#0004  INT  <S
P01  _
```

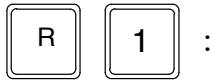

Press the key sequence



```
#0004  INT  <S
P01    R 1_
```

Press the  key:

```
#0004  INT  <S
P02  _
```

Press the key sequence   :

```
#0004  INT  <S
P02    R 2_
```

Press the  key:

```
#0005  INS  <S
_
```

Press the key sequence

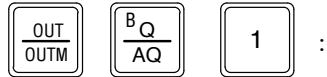

```
#0005  INS  <S
OUT    Q 1_
```

Press the  key:

```
#0006  INS  <S
_
```

Section 7: Control Functions

Control functions may be used to limit program execution and alter the way the CPU executes the application program:

Abbreviation	Function	Description
DoI/O	DOI/O	Services for one sweep a specified range of inputs or outputs immediately
Nested Jump	JUMP	Causes program execution to jump to a specified location in the logic.
Nested Master Control Relay	MCR	Programs a master control relay. An MCR causes all rungs between the MCR and the next END MCR function to be executed with negative power flow.
End MCR	END MCR	Terminates a control range extending to the closest preceding/succeeding JUMP or preceding MCR function.
Label	LABEL	Provides a target destination for a jump.
No Operation	NOOP	Supports rung comment functionality, by performing no operation.
End Sweep	ENDSW	Acts as a temporary end to executing program logic.
System Service Request	SVCRQ	Requests a special PLC service.
PID ISA PIDIND	PIDISA/PIDIND	Implements standard ISA PID (proportional/integral/derivative) ISA and independent term PID IND algorithms.
Subroutine call	CALL	Causes program execution to go to a specified subroutine declaration.

Descriptions of each of these functions are included in this section.

Do I/O Snapshot (DOI/O) Function 85

The do I/O snapshot function (DOI/O) is a conditionally executed function which performs an immediate I/O snapshot of a designated range of discrete or analog inputs or outputs.

When the logic controlling the enable input to this function passes power flow to the functions enable input the function is executed by the CPU and a new Do I/O function will take place. During the execution of a Do I/O function the logic solving portion of the CPU scan is suspended (placed on hold) and a specified group of real world inputs or output are serviced (updated). That is; the on/off condition of the specified inputs are placed into memory or the data from the CPU memory is sent out to update the specified hardware outputs. This takes place when the step containing this Do I/O is solved during the logic solution portion of the CPU scan, and does not wait for the normal output scan which takes place at the end of the logic solution or the input scan which takes place just before the logic solution portion of the CPU scan. The normal input and output scans will still take place at their regular time during the CPU's total scan.

Only one type of real world inputs or outputs may be updated during a single execution of a Do I/O function and only those inputs or outputs that are in the range specified by parameters P1 (ST) and P2 (END). Parameter P1 (ST) is the starting address of the group of real world inputs or outputs to be serviced. The reference associated with the starting and ending address must have the same prefix (%I, %Q, %AI, or %AQ).

The update of the inputs and outputs during this Do I/O function is performed in groups of eight (8) points at a time when discrete inputs or outputs (%I or %Q) are specified, therefore the minimum number of points in the group of points specified by parameter P1 and P2 is 8, and the maximum is restricted by the number of real inputs or outputs points supported by the system. Note that Do I/O scans occur on I/O module boundaries and I/O scans of part of the module's I/O are not supported. For example, if 8 points are specified in a Do I/O function for a 16 point Input module, the entire module's 16 points will be scanned. This also means that when discrete inputs or outputs are specified by parameters P1, P2 or P3 the parameter number specified must be on an 8 point boundary (if an 8 point discrete module is used), except when parameter P3 (ALT) specifies a register (%R) location then the number specified by parameter P1 and P2 must be on a 16 point boundary.

When analog inputs or analog outputs (%AI or %AQ) are specified by parameter P1, P2, or P3 the minimum number of points specified is 16 or one analog channel, and the maximum is restricted by the number of real analog channels supported by the system. This also means that if discrete memory points are used for parameter P3 the number specified by parameter P3 must be on a 16 point boundary.

Execution of the function continues until all inputs or outputs in the selected range specified by parameters P1 and P2 are serviced. Then the program logic execution will return to execute the logic located in the next step following the step containing this Do I/O function.

If the specified references include a smart I/O module, such as a High Speed Counter or Axis Positioning Module, the ALT parameter (P1) will be ignored for the references assigned to that module. That is, the real world input will be put into or outputs taken from the references configured for that module, as if no ALT parameter had been programmed. All of the inputs or outputs of a smart I/O module are scanned. That is, if either %I or %AI are specified by P1 and P2, then *BOTH* %I and %AI (if present) will be scanned from the smart module. If *EITHER* %Q or %AQ are specified by P1 and P2, both %Q and %AQ will be scanned to the smart module. Note that the Do I/O function is not allowed with the Enhanced GCM (GCM+) and GCM modules.

If parameter P3 is programmed as a -1 (minus 1), then the function will be executed as if P3 were not programmed.

P1:	%I or %AI	Condition of these inputs will be stored in the table memory locations specified by parameter P3.
P2:	%I or %AI	
P3:	%I or %AI %Q or %AQ	
P1:	%I or %AI	Condition of these real world inputs are stored in the memory table in the CPU with the same memory address as P1 and P2.
P2:	%I or %AI	
P3:	-1	
P1:	%Q or %AQ	The data located in the memory location specified by P3 is used as the source to update these real world outputs.
P2:	%Q or %AQ	
P3:	%Q or %AQ %I or %AI	
P1:	%Q or %AQ	The data located in the CPU memory locations specified by P1 and P2 is used to update the real world outputs whose address is given by P1 and P2.
P2:	%Q or %AQ	
P3:	-1	

Power flow through this function will take place when the input or output update is complete and this functions enable input has power flow, unless:

- Not all references of the type specified are present within the selected range.
- The CPU is not able to properly handle the temporary list of I/O created by the function.
- The range specified includes I/O modules that are associated with a *Loss of I/O* fault.

As many Do I/O Functions may be programmed into the CPU as necessary. Note that each Do I/O function will increase the scan time and the watch dog timer may time out.

To prevent multiple Do I/O functions from taking place it is advisable to have the power flow to the enable input be controlled by a contact off of a one shot element (OUT+ or OUT-).

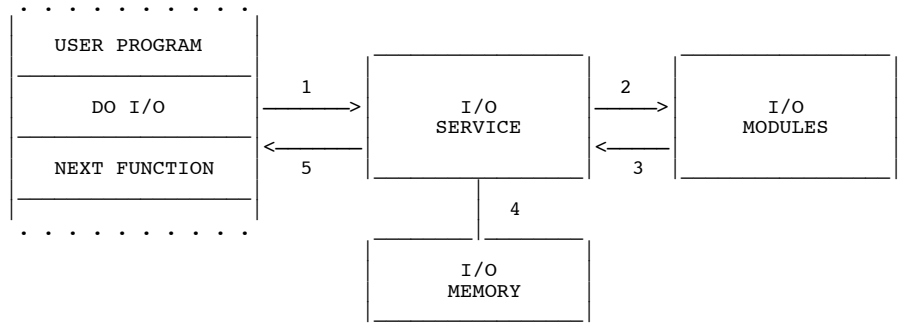

Logic controlling power flow to the enable input(enable)	- DO_IO -	Power flow through this function to control another function or coil
Starting address of input or outputs to be serviced	(P01) - ST	
Ending address of inputs or outputs to be serviced	(P02) - END	
Alternate CPU location for storage or source data for inputs or outputs.	(P03) - ALT	

Programming Elements and Sequential Order of Programming

1. Logic controlling the enable input from the left bus. This logic must start with an LD element.
2. Function type: Function 85.
3. Parameter P1 (ST): starting address of real world inputs (%I or %AI) or outputs (%Q or %AQ) to be serviced.
4. Parameter P2 (END): ending address of real world inputs (%I or %AI) or outputs (%Q or %AQ) to be serviced.
5. Parameter P3 (ALT): alternate CPU memory location for storage or source data for inputs or outputs.

Allowable Memory Types for DOI/O (Function 85)

Parameter	%I	%Q	%M	%T	%G	%S	%R	%AI	%AQ	Constant
ST (P01)	•	•						•	•	
END (P02)	•	•						•	•	
ALT (P03)	•	•	•	•	•		•	•	•	

Programming Example for DOI/O Function

In this example a contact from a one shot (OUT+) is used as the controlling element for the power flow to the enable input of the Do I/O function. When input %I0001 closes (passes power flow), %M0067 will pass power flow to the enable input of the Do I/O function for only one sweep of the CPU scan. Therefore, the Do I/O will only occur once each time input 1 is closed. When the enabling input %M0067 is true, references %I0001 through %I0064 are scanned and %Q0001 is turned on. A copy of the scanned inputs is placed in internal memory from reference %M0001 through %M0064. The real input points are not updated. This form of the function can be used to compare the current values of input points with the values of input points at the beginning of the scan.

Ladder Diagram Representation

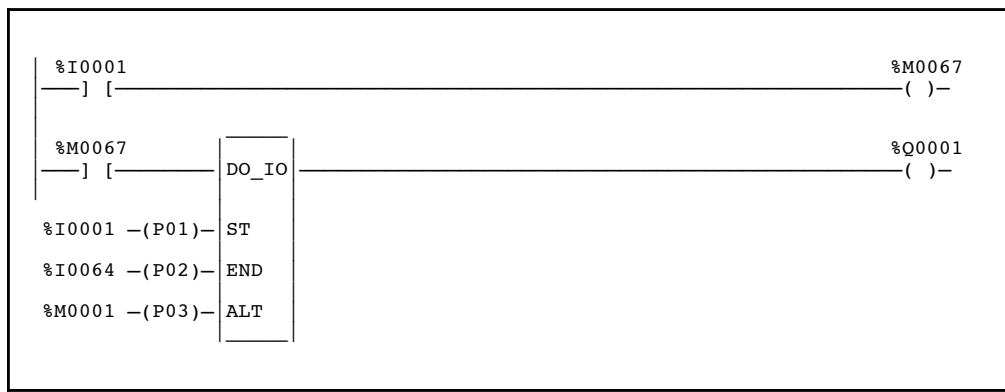

Statement List Representation

#0001:	LD		%I0001
#0002:	OUT+		%M0067
#0003:	LD		%M0067
#0004:	FUNC	85	DOIO
		P1:	%I0001
		P2:	%I0064
		P3:	%M0001
#0005	OUT		%Q0001

After pressing  key: Programming sequence



Key Strokes

HHP Display

Initial display:

```
#0001  INS  <S
_
```

Press the key sequence





   :

```
#0001  INS  <S
LD      I 1_
```

Press the  key:

```
#0002  INS  <S
_
```

Press the key sequence

     :

```
#0002  INS  <S
OUT+    M 67_
```

Press the  key:

```
#0003  INS  <S
_
```

Press the key sequence

    :

```
#0003  INS  <S
LD      M 67_
```

Press the  key:

```
#0004  INS  <S  
_
```

Press the key sequence

   :

```
#0004  INS  <S  
FUNC  85_ DOIO
```

Press the  key:

```
#0004  DOIO  <S  
P01  _
```

Press the key sequence

  :

```
#0004  DOIO  <S  
P01      I 1_
```

Press the  key:

```
#0004  DOIO  <S  
P02  _
```

Press the key sequence

   :

```
#0004  DOIO  <S  
P02      I 64_
```

Press the  key:

```
#0004  DOIO  <S  
P03  _
```

Press the key sequence   :

```
#0004  DOIO  <S  
P02      M 1_
```

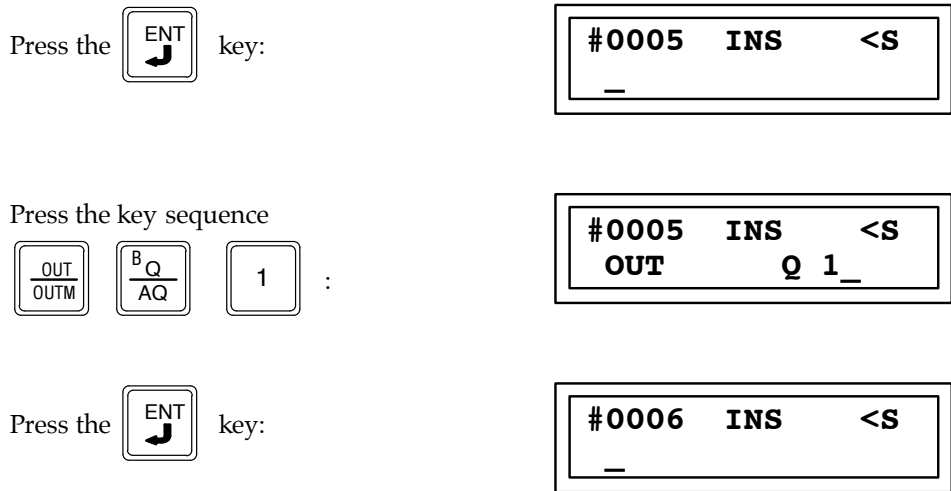

Enhanced DO I/O Function for Model 331 and Higher

Caution

If the Enhanced DO I/O function is used in a program, the program should not be loaded by a version of Logicmaster 90-30/20 software earlier than 4.01.

An enhanced version of the DO I/O (DOIO) function is available for Release 4.20, or later, of all models except the Model 211 CPU. This enhanced version of the DOIO function can only be used on a single discrete input or discrete output 8-point, 16-point, or 32-point module.

The ALT parameter identifies the slot in the main (CPU) rack that the module is located in. For example, a constant value of 2 in this parameter indicates to the CPU that it is to execute the enhanced version of the DOIO function block for the module in slot 2.

Note

The only checking done by the enhanced DOIO function block is to check the state of the module in the slot specified to see if the module is okay.

The enhanced DOIO function only applies to modules located in the main (CPU) rack. Therefore, the ALT parameter must be between 2 and 5 for a 5-slot rack or 2 and 10 for a 10-slot rack.

The start and end references must be either %I or %Q. These references specify the first and last reference the module is configured for. For example, if a 16-point input module is configured at %I0001 through %I0016 in slot 10 of a 10-slot main rack, the ST parameter must be %I0001, the END parameter must be %I0016, and the ALT parameter must be 10, as shown below:

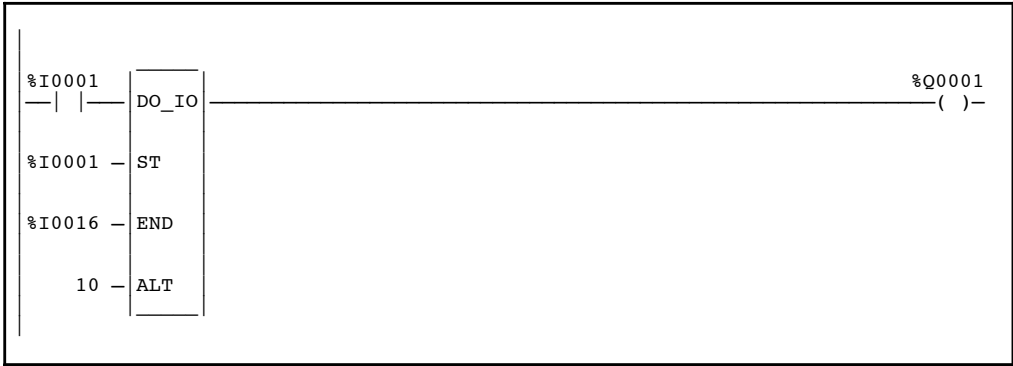

The following table compares the execution times of a normal DOIO function block for an 8-point, 16-point, or 32-point discrete input/output module with those of an enhanced DOIO function block.

Module	Normal DOIO Execution Time	Enhanced DOIO Execution Time
8-Pt Discrete Input Module	224microseconds	67microseconds
8-Pt Discrete Output Module	208microseconds	48microseconds
16-Pt Discrete Input Module	224microseconds	68microseconds
16-Pt Discrete Output Module	211microseconds	47microseconds
32-Pt Discrete Input Module	247microseconds	91microseconds
32-Pt Discrete Output Module	226microseconds	50microseconds

Terminate Program Logic Execution (ENDSW) Function 0

The terminate program logic execution function (ENDSW) is an unconditionally executed function which acts as a (temporary) program logic execution stream terminator. It is normally used during system debug.

ENDSW is an unconditionally executed function which terminates the execution of program logic instructions. This function is normally not used in a program, but may be used as a temporary end of program while debugging program logic. Programming of this function does *not* prevent you from viewing succeeding instructions.

No Operation (NOOP) Function 1

The no operation function (NOOP) is an unconditionally executed function which performs no operation. It is used only in support of the Logicmaster 90-30/20 software package. NOOPs may appear in a statement list program after Logicmaster 90-30/20 software has downloaded a program.

This function can be only be viewed and deleted by the Hand-Held Programmer. It cannot be entered using the Hand-Held Programmer.

Nested Jump (JUMP) Function 3

The nested JUMP function is an unconditionally executed function which is used to cause a specified portion of the program logic to be bypassed. Normal program execution will continue at the portion of the program specified by the LABEL function. The nested JUMP function is enabled when power flows to the enable input. When the function executes, the program will jump to the LABEL specified by the JUMP function. If this jump is in the forward direction, the instructions between the JUMP function and the LABEL function will be skipped. If the jump is in the backward direction, the instructions between the LABEL and the JUMP functions will be repeated.

A forward jump sequence has the following form:

```
[...JUMP TO N...LABEL N...]
```

A backwards jump sequence has the following form:

```
[...LABEL N...JUMP TO N...]
```

Warning

You must ensure that the logic solution repetition caused by a backward jump is terminated with the maximum allowable sweep time (200 ms). If the repetition is allowed to continue beyond the maximum sweep time, the PLC watchdog timer will time out. This will cause the PLC to come to a complete shut down with the OK and RUN LEDs off and with the outputs placed in their default states. This could create a situation which could damage equipment or cause personal injury. For Model 311, 313, and 331 CPUs, the only way to get the PLC out of this state is to power off the PLC and then power it back on with the Hand-Held Programmer connected and simultaneously pressing the RUN and NOT keys. CPU Models 340, 341, 351, and 211 will reset themselves, generate a watchdog timer fault, and resume operation in STOP mode.

The following programming rules apply to the JUMP function:

- JUMP instructions and their associated labels can be nested in any order.
- Multiple JUMPs to the same label are allowed.
- The JUMP nesting levels are restricted only by the maximum number of 256 specified by LABEL plus the END MCR limit.
- Backwards jumps are allowed.
- New JUMP instructions cannot be within the scope of the format of (release 1) of MCRs and JUMPs. In addition, the previous format of MCRs and JUMPs cannot be programmed within the scope of new MCR instructions.
- The new (release 2 and later) of JUMP instructions can be nested within the scope of the new (release 2 and later) MCR instructions.

The following table specifies valid memory types for the P1 parameter of the nested JUMP function.

Allowable Memory Types for nested JUMP (Function 3)

Parameter	%I	%Q	%M	%T	%S	%SA	%SB	%SC	%G	%R	%AI	%AQ	Constant
LABEL(P01)													•

Programming Example for JUMP Function

The following example logic is a nested JUMP function having a single input to enable the function. The logic, when enabled will cause a jump to LABEL number 12.

Ladder Diagram Representation

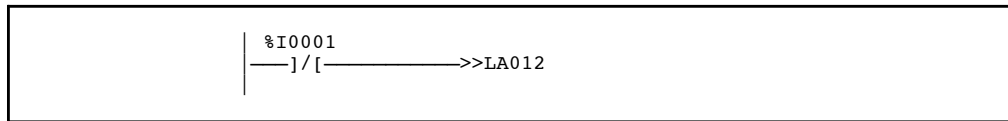

Statement List Representation

```

#0001    LD      NOT    %I0001
#0002    FUNC   03     JMP
P1:      12
  
```

After pressing INS key: Programming sequence

Key Strokes

HHP Display

Initial display:

```
#0001  INS  <S
_
```

Press the key sequence

LD
F NOT
AI AI
1 :

```
#0001  INS  <S
LD NOT  I 1_
```

Press the ENT key:

```
#0002  INS  <S
_
```

Press the key sequence FUNC 3 :

```
#0002  INS  <S
FUNC 03_ JMP
```

Press the  key:

```
#0002 JMP <S
P01 _
```

Press the key sequence   :

```
#0002 JMP <S
P01 12_
```

Press the  key:

```
#0003 JMP <S
_
```

Programming Example for LABEL Function

The following example shows how a LABEL function is provided for the previous JUMP function.

Ladder Diagram Representation

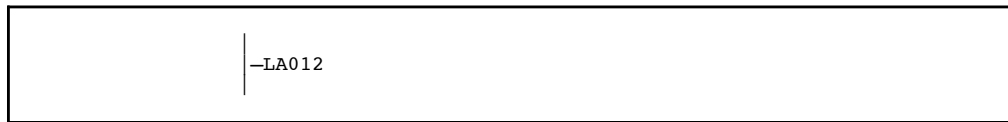

Statement List Representation

```
#0021    FUNC    07    LABEL
          P1:    12
```



After pressing  key: Programming sequence

Key Strokes

HHP Display

Initial display:



```
#0021 INS <S
_
```

Press the key sequence   :

```
#0021  INS  <S  
FUNC 07_ LABEL
```

Press the  key:

```
#0021  LABEL <S  
P01  _
```

Press the key sequence   :

```
#0021  LABEL <S  
P01  12_
```

Press the  key:

```
#0022  INS  <S  
_
```

Nested Master Control Relay (MCR) Function 4

The nested MCR function is an unconditionally executed function used to control execution of portions of logic. When power flows to the MCR function through the enable input all coils (except Latch and Reset Latch coils, which are not affected) between the Master Control Relay (MCR) and the next End MCR function with a matching label number will be turned off.

The nested MCR has one parameter, which is a number assigned to LABEL between 0 and 255. This number and the matching LABEL number of an END MCR function identify the scope of the nested MCR function.

The following rules apply to programming the MCR function:

- MCRs and END MCRs must be properly nested. That is, the scope of an MCR must be either completely within the scope of another MCR or completely out of the scope of another MCR.
- You can program multiple MCRs for the same END MCR (not applicable to CPU351).
- The maximum MCR nesting level is the maximum number (256) which can be assigned to LABEL plus the END MCR limit.
- The MCR function must be located in the program prior to its matching END MCR function.
- New MCR instructions cannot be within the scope of the previous format (release 1) MCRs and JUMPs (previous format not available in CPU351). In addition, the previous format of MCRs and JUMPs can not be programmed within the scope of new MCR instructions.

The following table specifies which memory types are valid for the P1 parameter of the nested MCR function.

Allowable Memory Types for Nested Master Control Relay (Function 4)

Parameter	%I	%Q	%M	%T	%S	%SA	%SB	%SC	%G	%R	%AI	%AQ	Constant
LABEL(P01)													•

END MCR Function 8

The END MCR is an unconditionally executed function is used to resume normal program execution after a nested MCR function. The END MCR has one parameter, which is a number assigned to LABEL between 0 and 255. This number and the matching LABEL number of a prior nested MCR function identify the scope of the nested MCR function. A maximum of 256 LABELS, END MCRs, and CEND (CEND available with release 1 only) instructions are allowed in a program.

The following table specifies which memory types are valid for the P1 parameter of the END MCR function.

Allowable Memory Types for End MCR (Function 8)

Parameter	%I	%Q	%M	%T	%G	%S	%SA	%SB	%SC	%R	%AI	%AQ	Constant
LABEL(P01)													•

Programming Example for MCR Function

The following example shows a nested MCR function assigned a LABEL number of 14 that is to be paired with an END MCR assigned the same number.

Ladder Diagram Representation

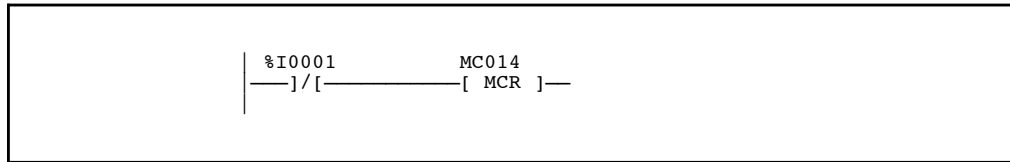

Statement List Representation

```
#0001 LD NOT %I0001
#0002 FUNC 04 MCR 14
```

After pressing  key: Programming sequence





Key Strokes

HHP Display

Initial display:

```
#0001 INS <S
_
```

Press the key sequence

    :

```
#0001 INS <S
LD NOT I 1_
```

Press the  key:



```
#0002 INS <S
_
```

Press the key sequence   :

```
#0002 INS <S
FUNC 04_ MCR
```

Press the  key:

```
#0002 MCR <S
P01 _
```

Press the key sequence   :

```
#0002 MCR <S
P01 14_
```

Press the  key:

```
#0003 INS <S
_
```

Programming Example for END MCR Function

The following example shows an END MCR function assigned a LABEL number of 14 that is to be paired with the above nested MCR function assigned the same label number.

Ladder Diagram Representation



Statement List Representation

```
#0021  FUNC  08  ENDMCR
          P1:  14
```



After pressing  key: Programming sequence

Key Strokes

HHP Display

Initial display:

```
#0021  INS  <S
_
```

Press the key sequence   :

```
#0021  INS  <S  
FUNC 08_ ENDMC
```

Press the  key:

```
#0021  ENDMC  <S  
P01  _
```

Press the key sequence   :

```
#0021  ENDMC  <S  
P01  14_
```

Press the  key:

```
#0022  INS  <S  
_
```

LABEL Function 7

The LABEL function is an unconditionally executed function which provides the destination of a JUMP TO (nested JUMP) function with a matching LABEL number. A maximum of 256 LABELS, END MCRs, and CEND (CEND available with release 1 only) instructions are allowed in a program.

The following table lists valid memory types for the P1 parameter of the END MCR function.

Allowable Memory Types for LABEL (Function 7)

Parameter	%I	%Q	%M	%T	%S	%SA	%SB	%SC	%G	%R	%AI	%AQ	Constant
LABEL(P01)													•

System Service Request (SVCRQ) Function 89

The system service request function (SVCRQ) is a conditionally executed function which is used to request one of the PLC's special services. These special services are listed in the following table.

Table 9-7. Service Request Functions

Function	Description
6	Change / ReadChecksumTask State and Number of Words to Checksum.
7	Change / ReadTime of Day Clock (only formats 1 and 3 are supported).
13	Shut Down (stop) the PLC.
14	Clear PLC Fault Tables.
15	Read Last Fault Table Entry.
16	Read Elapsed Time Clock.
18	ReadI/OOverrideStatus.

The SVCRQ function has three inputs and one output. When the SVCRQ function receives power flow, the PLC is requested to perform the function (FNC) indicated. Parameters for the function begin at the reference given for PARM. The SVCRQ function passes power flow unless an incorrect function number, incorrect parameters, or out of range references are specified. The OK output is set to a one (true) if a system service request is activated and is successful; otherwise, it is set to a 0 (false).

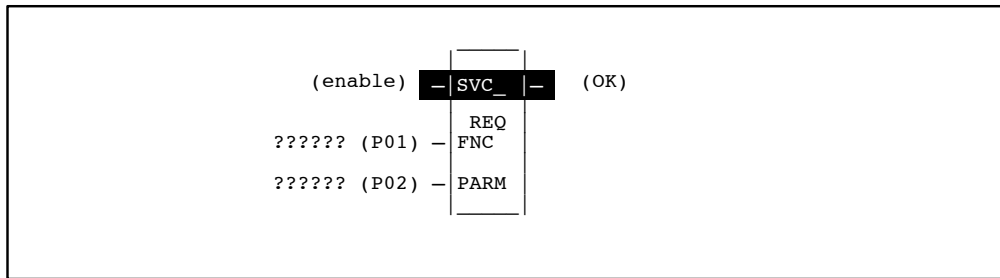

Programming Elements and Sequential Order of Programming

1. Logic controlling the enable input from the left bus. This logic must start with an LD element.
2. Function type: Function 89.
3. Parameter P1 (FNC): this is a number corresponding to the available special service requests (see table above). This can be a constant number or the memory location of a register containing the value.
4. Parameter P2 (PARAM): memory location of parameters for the requested function. This is a register memory location that contains a block of parameters for the selected function.

The following table specifies which memory types are valid for each of the SVCRQ function parameters:

Allowable Memory Types for SVCRQ (Function 89)

Parameter	%I	%Q	%M	%T	%G	%S	%R	%AI	%AQ	Constant
Request FNC (P01)							•			•
Output PARAM (P02)							•			

Programming Example for SVCRQ Function

In the following example, when the enabling input %I0001 is closed, it passes power flow to the enable input and a new SVCRQ function number 7 (specified in parameter P1) is called with the parameter block located starting at %R0001 as specified in parameter P2. Output coil %Q0001 is set true if the operation succeeds.

Ladder Diagram Representation

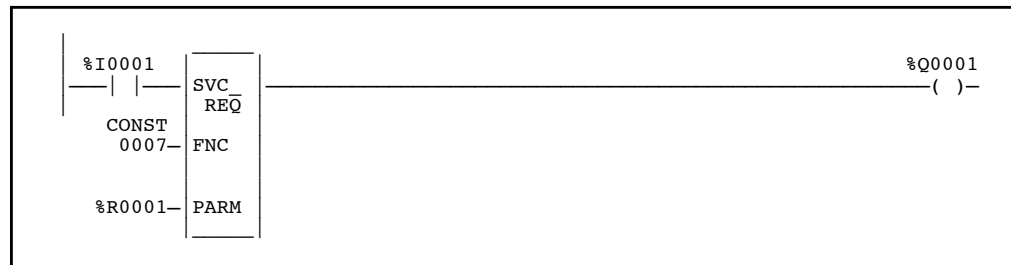

Statement List Representation

```

#0001: LD          %I0001
#0002: FUNC      89  SVCRQ
          P1:      7
          P2:     %R0001
#0003: OUT      %Q0001
    
```

After pressing INS key: Programming sequence

Key Strokes

HHP Display

Initial display:

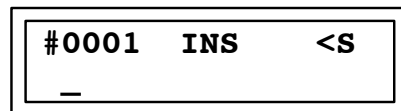

Press the key sequence

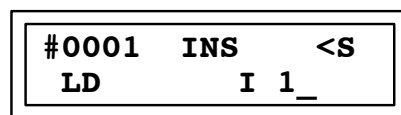
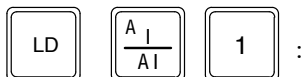

Press the  key:

```
#0002  INS  <S  
_
```

Press the key sequence

   :

```
#0002  INS  <S  
FUNC  89_  SVCRO
```

Press the  key:

```
#0002  SVCRO <S  
P01  _
```

Press the key sequence  :

```
#0002  SVCRO <S  
P01      7_
```

Press the  key:

```
#0002  SVCRO <S  
P02  _
```



Press the key sequence   :

```
#0002  SVCRO <S  
P02      R 1_
```

Press the  key:

```
#0003  INS  <S  
_
```

Press the key sequence

   :

```
#0003  INS  <S  
OUT      Q 1_
```

Press the  key:

```
#0004  INS  <S  
_
```

PID ISA (PIDISA) Function 86

PID IND (PIDIND) Function 87

The PID ISA (PIDISA) and PID IND (PIDIND) functions are conditionally executed functions which, when executed, will implement the ISA standard algorithm (PID ISA) or the independent term algorithm (PID IND), respectively. Boolean outputs, parameters, and memory type restrictions are identical for both algorithms. PID is an acronym for proportional/integral/derivative.

The PID function is designed to solve one loop equation in one execution. The function block data uses 40 registers in a loop data table. The first 35 registers are reserved for the function and should not be used by any application program. The last 5 registers are reserved for external use.

Registers cannot be shared. If there are multiple occurrences of the same PID function controlling multiple loops, each occurrence requires a separate block of 40 registers.

The PIDISA and PIDIND functions provide two PID (proportional/integral/derivative) closed-loop control algorithms.

The PID function has seven input parameters: a Boolean enable, a process set point (SP), a process variable (PV), a manual/auto Boolean switch (MAN), a manual mode up adjustment input (UP), and a manual mode down adjustment (DN). It also has an address, which specifies the location of a block of parameters associated with the function. It has two output parameters, a successful Boolean output (ok) and the control variable result (CV).

When there is power flow at the enable input and no power flow at MAN, the PID algorithm is applied to SP and PV, with the result placed in CV. OK is set to a one (true) if the PID function executes successfully; or if the elapsed time was less than 10 ms and the algorithm was set to run every sweep otherwise, it is set to a 0 (false).

When there is power flow at the enable input and MAN, the PID block is placed into manual mode. Output CV maintains its current value and can be adjusted with the UP and DN inputs. While the PID block is in manual mode, the PID algorithm is executed so that the calculated result tracks with the manually controlled CV value. This prevents the PID function from building up an integral component while in manual mode, and provides bumpless transfer when the block is placed back into automatic mode.

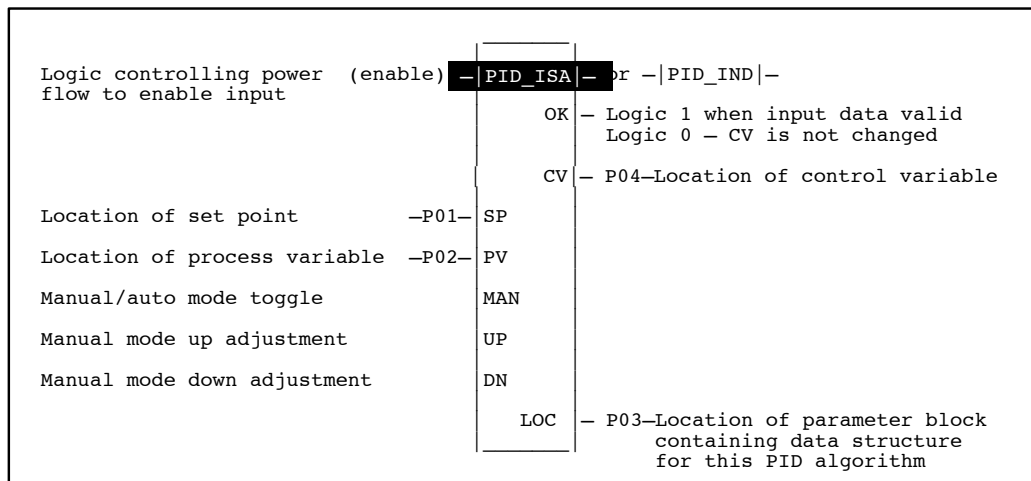

Parameters for PID Function

Parameter	Description
enable	When enabled, the PID function is performed.
SP (P01)	SP is the control loop set point.
PV (P02)	PV is the control loop process variable.
MAN	When energized, the PID function is in manual mode.
UP	When energized, if in manual mode, the CV output is adjusted up.
DN	When energized, if in manual mode, the CV output is adjusted down.
LOC (P03)	This is the address of the memory location of the PID control block information.
OK	The ok output is energized when the function is performed without error.
CV (P04)	CV is the control variable output.

Programming Elements and Sequential Order of Programming

1. Logic controlling the enable input from the left bus. This logic must start with an LD element.
2. Function type: Function 86 (PIDISA) or Function 87 (PIDIND).
3. Parameter P1 (SP): the control loop set point. This is a signed word value which can be a constant number or the address of a memory location containing the value.
4. Parameter P2 (PV): the control loop process variable. This is a signed word value which is stored in a specified memory location.
5. Parameter P3 (LOC): address location of PID control block information. The starting register number for 40 consecutive registers containing the data table for one PID function.
6. Parameter P4 (CV): an output which is the location of the control variable result. This is the memory address for the location of the reference which will contain the control variable result.

The following table specifies which memory types are valid for each of the PIDISA and PIDIND function parameters:

Allowable Memory Types for PIDISA/PIDIND (Functions 86/87)

Parameter	flow	%I	%Q	%M	%T	%S	%G	%R	%AI	%AQ	const	none
enable	•											
SP		•	•	•	•		•	•	•	•	•	
PV		•	•	•	•		•	•	•	•		
MAN	•											
UP	•											
DN	•											
LOC								•				
OK	•											•
CV		•	•	•	•		•	•	•	•		

• = Valid reference or place where power may flow through the function.

PID Data Structure

The parameter block associated with each PID function block contains the data items as shown below. The location of this parameter must be a register specified by the entry for the LOC (P03) parameter.

%Ref+0000	Loop Number *
%Ref+0001	Algorithm **
%Ref+0002	Sample Period *
%Ref+0003	Dead Band + *
%Ref+0004	Dead Band - *
%Ref+0005	Proportional Gain *
%Ref+0006	Derivative *
%Ref+0007	Integral Rate *
%Ref+0008	Bias *
%Ref+0009	Upper Clamp *
%Ref+0010	Lower Clamp *
%Ref+0011	Minimum Slew Time *
%Ref+0012	Config Word *
%Ref+0013	Manual Command *
%Ref+0014	Control Word **
%Ref+0015	Internal SP **
%Ref+0016	Internal CV **
%Ref+0017	Internal PV **
%Ref+0018	Output **
%Ref+0019	Diff Term Storage **
%Ref+0020	Int Term Storage **
%Ref+0021	Int Term Storage **
%Ref+0022	Slew Term Storage **
%Ref+0023	Clock **
%Ref+0024	(time last executed)
%Ref+0025	Y Remainder Storage **
%Ref+0027	Lower Range for SP, PV *
%Ref+0028	Upper Range for SP, PV *
%Ref+0029	• Reserved for internal use
%Ref+0034	• Reserved for external use
%Ref+0035	•
%Ref+0039	•

* = May be set by the user.
 ** = Set and maintained by the PLC.

The loop number, execution interval, deadband \pm , proportional gain, differential gain, integral rate, bias, upper/lower clamp, minimum slew time, and config word values must be set by the application program. The other values are maintained by the PID function block.

There is an important restriction on the use of the PID function. The PID will not execute more often than once every 10 msec. This could change your expected results if you set it up to execute every sweep and the sweep is less than 10 msec. In such a case, the PID function will not run until enough sweeps have occurred to accumulate an elapsed time of 10 msec; e.g., if the sweep time is 9 msec, the PID function will execute every other sweep with an elapsed time of 18 msec for every time it executes.

Table 9-8. PID Function Block Data

Data Item	Description
LoopNumber	An unsigned integer that provides a common identification in the PLC with the loop number defined by an operator interface device. The loop number is displayed under the block address when logic is monitored from the Logicmaster 90-30 software. Use of the loop number is optional.
Algorithm	An unsigned integer that is set by the PLC to identify what algorithm is being used by the function block. The ISA algorithm is defined as algorithm 1, and the interactive algorithm is identified as algorithm 2.
Sample Period	The time in increments of 0.01 seconds between executions of the function block. The PID function is calculated at this interval. The function compensates for the actual time elapsed since the last execution, within 100 microseconds. If this value is set to 0, the function is executed each time it is enabled; however, it is restricted to a minimum of 10 milliseconds as noted above.
Dead Band (+/-)	Signed word values defining the upper (+) and lower (-) limits of the dead band interval, in counts. If no dead band is required, these terms should be set to 0. If the error is between the dead band (+) and (-) values, the function is solved with the error term set to 0. In other words, the error must grow beyond these limits before the PID block begins to adjust the CV output in response.
ProportionalGain	A signed word value that sets the proportional gain, in hundreds of seconds.
Derivative	A signed word value that sets the derivative, in hundreds of seconds.
IntegralRate	An unsigned word value that sets the integral rate, in units of repeats per 1000 seconds.
Bias	A signed word value that sets the bias term, in units of counts. Feed-forward control can be implemented by adjusting this value.
Upper and Lower Clamps	Signed word values that define the upper and lower limits on the CV output, in units of counts. Anti-reset windup is applied to the PID integral term when a clamp limit is reached. The integral term is adjusted to a value that holds the output at the clamped value.
Minimum Slew Time	An unsigned word value that defines the output minimum slew time. This term limits how quickly the output is allowed to change from 0 to 100%. This has the effect of limiting how quickly the integral term is allowed to change, preventing windup. If no slew rate limit is desired, this term should be set to 0. The slew rate limit is given in seconds for full travel.
Config Word	A word value with the following format:
	0 = Error Term. When this bit is set to 0, the error term is SP - PV. When this bit is set to 1, the error term is PV - SP.
	1 = Output Polarity. When this bit is set to 0, the CV output represents the output of the PID calculation. When it is set to 1, the CV output represents the negative of the output of the PID calculation.
	2 = Derivative action on PV. When this bit is set to 0, the derivative action is applied to the error term. When it is set to 1, the derivative action is applied to PV. All remaining bits should be zero.
ManualCommand	A signed word value that defines the output when in Manual mode.

Table 8-8. PID Function Block Data (continued)

Data Item	Description
Control Word	<p>A discrete data structure with the following format:</p> <p>0 = Override. 1 = Auto/Manual. 2 = Enable. 3 = Raise. 4 = Lower.</p> <p>Override: When the override bit is set to 1, the function block is executed based upon the current values of up, down, and manual; these values will not be written with the discrete inputs into the function block. When the override bit is set to 0, the up, down, and manual values are set to the values, as defined by the function block discrete inputs.</p> <p>Override also affects the values used for SP. If override is set, the function block will not update the value of SP and will execute based upon the SP value in the data structure.</p> <p>The purpose of the override bit is to allow the operator interface device to take control of the Boolean inputs into the function block so that they may be controlled by the operator interface device. In addition, since SP is not updated, the operator interface unit can also set override and take control of the set point.</p> <p>Enable: The enable bit will track the enable input into the function block.</p> <p>Manual/Raise/Lower: These three bits represent the state of the three Boolean inputs into the function block when the override bit is 0. Otherwise, they can be manipulated by an outside source.</p>
SP	This is a signed word value representing the set point input to the function block.
CV	This is a signed word value representing the CV output of the function block.
PV	This is a signed word value representing the process variable input to the function block.
Output	This is a signed word value representing the output of the function block before the application of the optional inversion. If no output inversion is configured and the output polarity bit in the control word is set to 0, this value will equal the CV output. If inversion is selected and the output polarity bit is set to 1, this value will equal the negative of the CV output.
Diff Term Storage	Used internally for storage of intermediate values. Do not write to this location.
Int Term Storage	Used internally for storage of intermediate values. Do not write to this location.
Slew Term Storage	Used internally for storage of intermediate values. Do not write to this location.
Clock	Internal elapsed time storage (time last executed). Do not write to these locations.
Lower Range	Lower range for SP, PV for faceplate display.
Upper Range	Upper range for SP, PV for faceplate display.
Reserved	Reserved for GE Fanuc use. Cannot be used for other purposes.

Initialization Values

The following table lists typical initialization values for the PID function block.

Register	Purpose	FB Units	Suggested Default	Range
%Ref+0	LoopNumber		1	
%Ref+2	Sample Period	10 ms	100 ms (10)	0 to 10.9 min
%Ref+3	Dead Band Selection +	Counts	320	0 to 100% of error
%Ref+4	Dead Band Selection -	Counts	320	0 to -100% of error
%Ref+5	ProportionalGain	0.01seconds	User Tuned	0 to 327.67 seconds
%Ref+6	Derivative	0.01seconds	User Tuned	0 to 327.67 seconds
%Ref+7	IntegralRate	Repeats per 1000 sec	User Tuned	0to32.767repeats/sec
%Ref+8	Bias	Counts	50% (16000)	-100% to +100%
%Ref+9	Upper Output Clamp	Counts	100% (32000)	-100% to +100%
%Ref+10	Lower Output Clamp	Counts	0% (0)	-100% to +100%
%Ref+11	Minimum Slew Time	Seconds per full travel	0	0 to 32767

Description Of Operation

When the PID function block is enabled, the configured execution interval (%Ref+2) is compared to the time since the last execution of the function block. If enough time has elapsed, the function block is executed. The PID loop equation is solved, based upon the actual elapsed time since the last complete execution rather than the programmed execution interval.

If the calculated control variable is beyond a configured clamp limit (%Ref+9 or %Ref+10) or has changed at a rate greater than the slew rate limit (%Ref + 11), the control variable is held to the appropriate limit and the integral storage is adjusted accordingly. This is referred to as anti-reset windup.

After the control variable is calculated, it is placed in the manual register (%Ref +13) and in the control variable storage register (%Ref +16) when the control is in auto mode. When the function block is placed in manual mode (power flow is passed to the manual input), the control variable output is held to the value in the manual register; and the manual register can be incremented or decremented by the up or down inputs to the function block. The manual register can also be loaded under program control in manual mode.

Bumpless operation is provided between manual and automatic modes because the integral storage term is adjusted while in manual mode, much as it is when a clamp or limit is reached. In manual mode, the control variable output is still restricted by the configured clamps and the slew rate limit. The slew rate limit can be used to prevent an operator from trying to adjust the control variable too quickly while in manual mode.

Difference between the PIDISA and PIDIND Functions

The standard ISA PID algorithm (PIDISA) applies the proportional gain to each of the proportional, differential, and integral terms, as shown in the block diagram below.

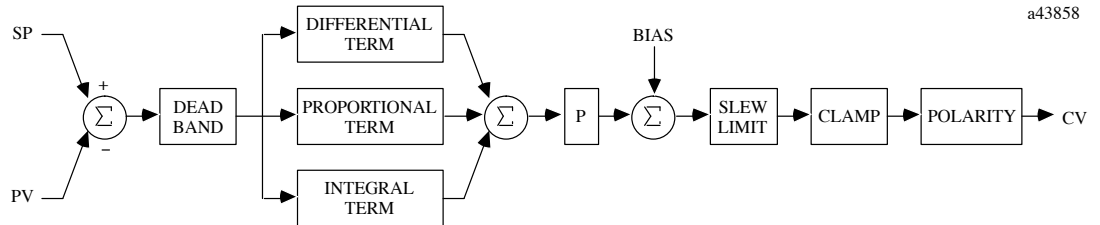

Figure 9-1. Standard ISA PID Algorithm (PIDISA)

The independent term algorithm (PIDIND) applies the proportional gain only to the proportional gain term, as shown in the block diagram below. Otherwise, the algorithms are identical.

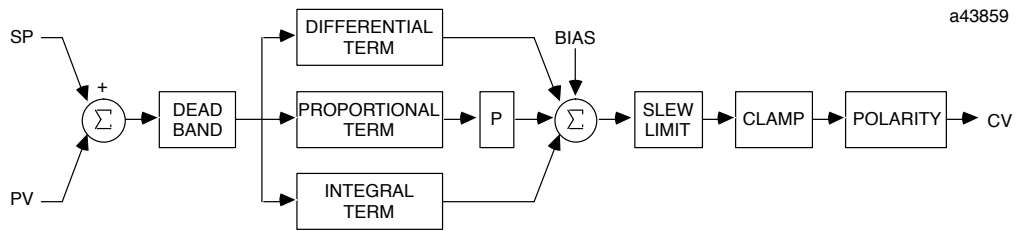

Figure 9-2. Independent Term Algorithm (PIDIND)

Ziegler and Nichols Tuning Approach

Changes to the proportional gain and the integral gain will affect the output immediately. They should be adjusted slowly and in small increments to allow the system to respond to their adjustments. Loop tuning should be done according to any established method used for process control loop tuning. One such method explained below is the Ziegler and Nichols Tuning Approach.

1. Determine the process gain; apply a unit step to the control variable output and measure the process variable response after it has stabilized. This response is K, the process gain.
2. Determine the process lag time. The process lag time t can be estimated as the time it takes the process variable to begin to react to a step change in the control variable. It is typically the point at which the process variable has reached its maximum rate of change.
3. Determine the equivalent system time constant. The equivalent system time constant T can be determined by the time it takes the process variable to reach 63% of its steady state value, from a step applied to the control variable minus the process lag time t .
4. Calculate the reaction rate R :

$$R = \frac{K}{T}$$

5. For proportional control only, calculate the Proportional Gain P :

$$P = \frac{1}{(R * T)}$$

6. For proportional and integral control, calculate Proportional Gain P and Integral Gain I :

$$P = \frac{0.9}{(R * T)}$$

$$I = \frac{0.3 * P}{t}$$

These should only be used as starting values for the tuning process. These values may vary with operating points in the process, if the process is time variant or non-linear. To assure that the tuning parameters are valid, all final adjustments should be made manually and the process monitored over all operating conditions and points.

Programming Example for PID Function

In this example, register %R1 contains the set point and register %R2 contains the process variable. %R100 is the first register in the parameter block. Whenever %I1 is closed (a "1") and %I2 is open (a "0"), the PID algorithm is applied to the function's inputs and the result is placed in register %R3. Whenever both %I1 and %I2 are closed (both "1"), the result placed in CV is adjusted by the states of inputs %I3 and %I4.

Ladder Diagram Representation

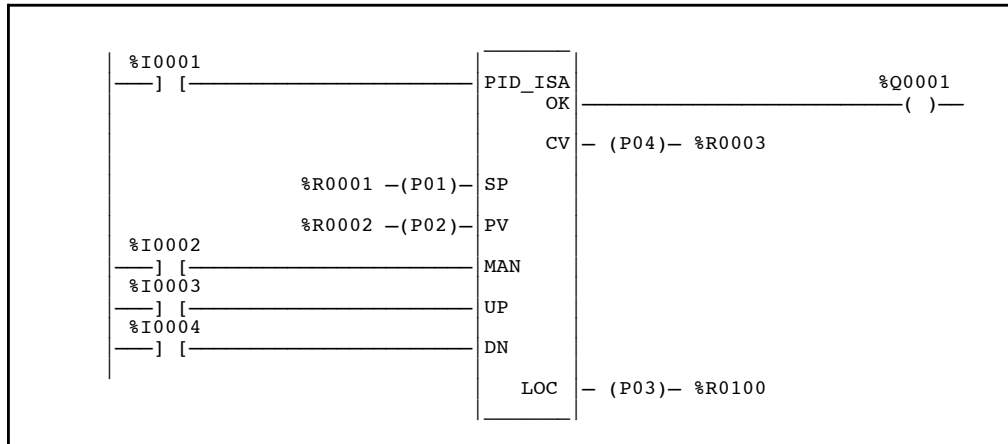

Statement List Representation

#0001	LD		%I0001
#0002	LD		%I0002
#0003	LD		%I0003
#0004	LD		%I0004
#0005	FUNC	86	PIDISA (or FUNC 87 PIDIND)
		P1:	%R0001
		P2:	%R0002
		P3:	%R0100
		P4:	%R0003
#0006	OUT		%Q0001

After pressing INS key: Programming sequence

Key Strokes

HHP Display

Initial display:

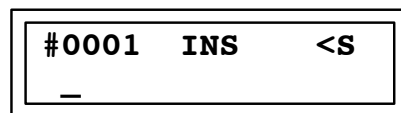

Press the key sequence

LD

A	
AI	

 1 :

```
#0001  INS  <S  
LD      I 1_
```

Press the

ENT ↓

 key:

```
#0002  INS  <S  
_
```

Press the key sequence

LD

A	
AI	

 2 :

```
#0002  INS  <S  
LD      I 2_
```

Press the

ENT ↓

 key:

```
#0003  INS  <S  
_
```

Press the key sequence

LD

A	
AI	

 3 :

```
#0003  INS  <S  
LD      I 3_
```

Press the

ENT ↓

 key:

```
#0004  INS  <S  
_
```

Press the key sequence

LD

A	
AI	

 4 :

```
#0004  INS  <S  
LD      I 4_
```

Press the

ENT ↓

 key:

```
#0005  INS  <S  
_
```



Press the key sequence



```
#0005  INS  <S  
FUNC 86_ PIDISA
```

Press the  key:

```
#0005  PIDISA <S  
P01  _
```

Press the key sequence   :

```
#0002  PIDISA <S  
P01   R1_
```

Press the  key:





```
#0005  PIDISA <S  
P02  _
```

Press the key sequence   :

```
#0005  PIDISA <S  
P02   R2_
```

Press the  key:



```
#0005  PIDISA <S  
_
```

Press the key sequence     :

```
#0005  PIDISA <S  
P03   R100_
```

Press the  key:

```
#0005  PIDISA <S  
P04  _
```

Press the key sequence   :

#0005	PIDISA	<S
P04	R3	_

Press the  key:

#0006	INS	<S
_		

Press the key sequence    :

#0006	INS	<S
OUT	Q 1	_

Press the  key:

#0007	INS	<S
_		

Subroutine Call (CALLSUB) Function 90

Entering a Subroutine Call (Function 90)

When a Subroutine Call Function is entered (see “Entering Subroutines”, page 9-7), that subroutine will be automatically declared, although it will be a null program (no logic) until you define it. To define the subroutine, zoom into it through the CALLSUB instruction or from the Subroutine Declaration List and enter the desired logic. The Subroutine Call function has one parameter, P1, which is the number of the subroutine you want to call. The following example shows how to enter a Subroutine Call function. Assume that you want to implement the following logic:



Programming Example for CALLSUB Function

The statement list instructions that you will enter to call subroutine 1 are as follows:

```
#0001: LD NOT %I0001
#0002: FUNC 90 CALLSUB
P1: 1
```

Enter the statement list program with the following key sequence:

After pressing  key: Programming sequence

Key Strokes

HHP Display

Initial display:

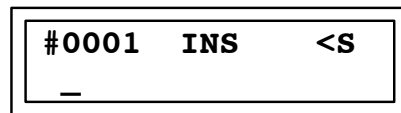

Press the key sequence

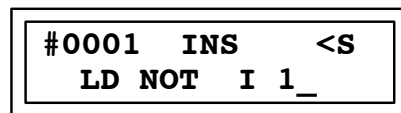
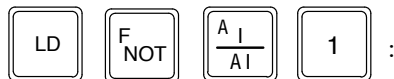

Press the  key:

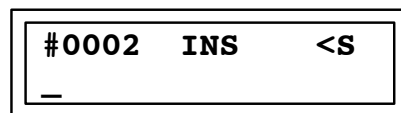

Press the key sequence

FUNC **9** **0** :

```
#0002  INS  <S  
FUNC 90_ CALLSUB
```

Press the **ENT** key:

```
#0002  CALLSUB <S  
P01  _
```

Press the key sequence **1** :

```
#0002  CALLSUB <S  
P01  1  _
```

Press the **ENT** key:

```
#0002  INS  <S  
_
```

Section 8: Table Functions

Table functions are used to perform Array Search functions and Array Move functions. There are seven different functions in this group with each function able to operate on multiple data types as shown in the Data Type table below; thereby providing a total of 29 Table functions. Each of these functions are described in the following table.

Abbreviation	Function	Description
SRCH_EQ	SearchEqual	Search for all array values equal to a specified value.
SRCH_NE	Search Not Equal	Search for all array values not equal to a specified value.
SRCH_LT	Search Less Than	Search for all array values less than a specified value.
SRCH_LE	Search Less Than or Equal	Search for all array values less than or equal to a specified value.
SRCH_GT	Search Greater Than	Search for all array values greater than a specified value.
SRCH_GE	Search Greater Than or Equal	Search for all array values greater than or equal to a specified value.
ARRAY_MOVE	Array Move	Copy a specified number of data elements from a source array to a destination array.

The maximum length allowed for these functions is 32,767. Each of the Table functions can operate on the types of data shown in the following table:

Data Type	Description
INT	Signed integer.
DINT	Double-precision integer.
BIT *	Bit data type.
BYTE	Byte data type.
WORD	Word data type.

* Only available for ARRAY_MOVE.

Array Search Functions

The Array Search Functions can each operate on byte, word, integer, or double precision integer data types. Each of these functions and their function numbers are listed in the following table.

Table 9-9. Array Search Functions

Array Search type	Array data Type	Abbreviation	Function Number
Equal To	Byte	SREQB	101
	Word	SREQW	102
	Integer	SREQI	103
	Double Precision	SREQDI	104
Not Equal To	Byte	SRNEB	105
	Word	SRNEW	106
	Integer	SRNEI	107
	Double PrecisionInteger	SRNEDI	108
Less Than	Byte	SRLTB	109
	Word	SRLTW	110
	Integer	SRLTI	111
	Double PrecisionInteger	SRLTDI	112
Less Than or Equal To	Byte	SRLEB	113
	Word	SRLEW	114
	Integer	SRLEI	115
	Double PrecisionInteger	SRLEDI	116
Greater Than	Byte	SRGTB	117
	Word	SRGTW	118
	Integer	SRGTI	119
	Double PrecisionInteger	SRGTDI	120
Greater Than or Equal To	Byte	SRGEB	121
	Word	SRGEW	122
	Integer	SRGEI	123
	Double PrecisionInteger	SRGEDI	124

The following pages contain a description of each of the Array Search functions listed in the above table. Programming examples can be found at the end of the descriptions of all of the Array Search functions.

Note

Please note the following: Because of the similarity of the Array Search instructions, only one group of programming examples is provided. The previous table (Array Search Functions) lists all of the Array Search instructions along with their corresponding abbreviations and function numbers.

Search Equal To, Byte (SREQB) Function 101
Search Equal To, Word (SREQW) Function 102
Search Equal To, INT (SREQI) Function 103
Search Equal To, DINT (SREQDI) Function 104

The Search Equal To functions are conditionally executed functions which are used to search for all array values equal to a specified value.

Each function has four input parameters and two output parameters. When the function receives power, the array is searched starting at (AR + input NX). This is the starting address of the array (AR) plus the index into this array (input NX).

The search continues until the array element whose value is equal to the search object (IN) is found or until the end of the array is reached. If an array element is found, the output parameter (FD) is set to true and output parameter (output NX) is set to the relative position of this element within the array. If no element is found with a value equal (or not equal) to IN before the end of the array is reached, then output parameter (FD) is set to false and output parameter (output NX) is set to zero.

The valid values for the input NX are 0 to LEN – 1. This value increments by one at the time of execution. Therefore, the values of the output NX are 1 to LEN. If the value of the input NX is out-of-range, (< 0 or w LEN), its value is set to the default value of zero.

The function parameters for the Search Equal To functions are shown in the following illustration. The form of the function is the same for all Search Equal To functions; the only difference being the data type.

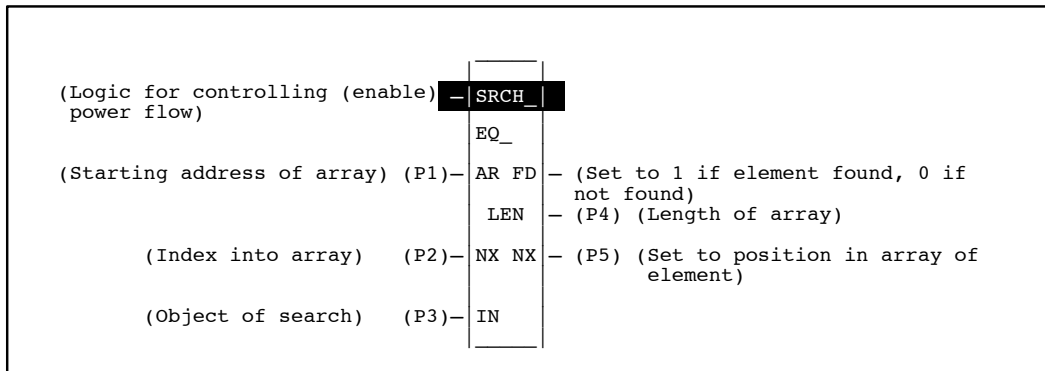

Description of Parameters for Search Equal To Functions

Parameter	Description
enable	When the function is enabled, the operation is performed.
AR(P011)	AR contains the starting address of the array to be searched.
Input NX (P02)	Input NX contains the index into the array.
IN (P03)	IN contains the object of the search.
LEN (P04)	LEN specifies the number of elements starting at AR that make up the array to be searched.
Output NX (P05)	Output NX holds the position within the array of the search target.
FD	FD indicates that an element whose value is equal to IN has been found and the function was successful.

Allowable Memory Types for Search Equal To Functions

Parameter	flow	%I	%Q	%M	%T	%S	%G	%R	%AI	%AQ	const	none
enable	•											
AR		o	o	o	o	n †	o	•	•	•		
NX in		•	•	•	•		•	•	•	•	•	
IN		o	o	o	o	n †	o	•	•	•	•	
LEN											•	
NX out		•	•	•	•		•	•	•	•		
FD	•											•

- = Valid reference or place where power may flow through the function.
- o = Valid reference for INT, BYTE, or WORD data only; not valid for DINT.
- n = Valid reference for BYTE or WORD data only; not valid for INT or DINT.
- † = %SA, %SB, %SC only; %S cannot be used.

Search Not Equal To, Byte (SRNEB) Function 105
Search Not Equal To, Word (SRNEW) Function 106
Search Not Equal To, INT (SRNEI) Function 107
Search Not Equal To, DINT (SRNEDI) Function 108

The Search Not Equal To functions are conditionally executed functions which are used to search for all array values not equal to a specified value.

Each function has four input parameters and two output parameters. When the function receives power, the array is searched starting at (AR + input NX). This is the starting address of the array (AR) plus the index into this array (input NX).

The search continues until the array element whose value is not equal to the search object (IN) is found or until the end of the array is reached. If an array element is found, the output parameter (FD) is set to true and output parameter (output NX) is set to the relative position of this element within the array. If no element is found with a value not equal to IN before the end of the array is reached, then output parameter (FD) is set to false and output parameter (output NX) is set to zero.

The valid values for the input NX are 0 to LEN – 1. This value increments by one at the time of execution. Therefore, the values of the output NX are 1 to LEN. If the value of the input NX is out-of-range, (< 0 or > LEN), its value is set to the default value of zero.

The function parameters for the Search Not Equal To functions are shown in the following illustration. The form of the function is the same for all Search Not Equal To functions; the only difference being the data type.

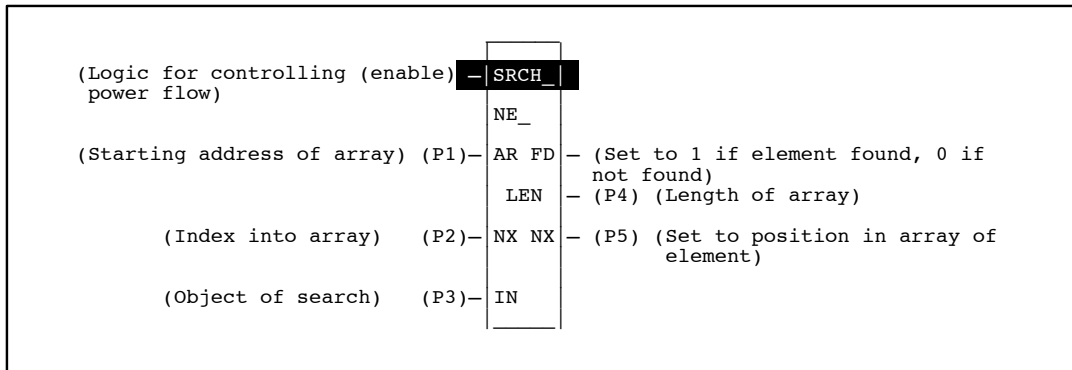

Description of Parameters for Search Not Equal To Functions

Parameter	Description
enable	When the function is enabled, the operation is performed.
AR(P01)	AR contains the starting address of the array to be searched.
Input NX (P02)	Input NX contains the index into the array.
IN (P03)	IN contains the object of the search.
LEN (P04)	LEN specifies the number of elements starting at AR that make up the array to be searched.
Output NX (P05)	Output NX holds the position within the array of the search target.
FD	FD indicates that an element whose value is not equal to IN has been found and the function was successful.

Allowable Memory Types for Search Not Equal To Functions

Parameter	flow	%I	%Q	%M	%T	%S	%G	%R	%AI	%AQ	const	none
enable	•											
AR		o	o	o	o	n †	o	•	•	•		
NX in		•	•	•	•		•	•	•	•	•	
IN		o	o	o	o	n †	o	•	•	•	•	
LEN											•	
NX out		•	•	•	•		•	•	•	•		
FD	•											•

- = Valid reference or place where power may flow through the function.
- o = Valid reference for INT, BYTE, or WORD data only; not valid for DINT.
- n = Valid reference for BYTE or WORD data only; not valid for INT or DINT.
- † = %SA, %SB, %SC only; %S cannot be used.

Search Less Than, Byte (SRLTB) Function 109
Search Less Than, Word (SRLTW) Function 110
Search Less Than, INT (SRLTI) Function 111
Search Less Than, DINT (SRLTDI) Function 112

The Search Less Than functions are conditionally executed functions which are used to search for all array values less than a specified value.

Each function has four input parameters and two output parameters. When the function receives power, the array is searched starting at (AR + input NX). This is the starting address of the array (AR) plus the index into this array (input NX).

The search continues until the array element whose value is less than the search object (IN) is found or until the end of the array is reached. If an array element is found, the output parameter (FD) is set to true and output parameter (output NX) is set to the relative position of this element within the array. If no element is found with a value less than IN before the end of the array is reached, then output parameter (FD) is set to false and output parameter (output NX) is set to zero.

The valid values for the input NX are 0 to LEN – 1. This value increments by one at the time of execution. Therefore, the values of the output NX are 1 to LEN. If the value of the input NX is out-of-range, (< 0 or w LEN), its value is set to the default value of zero.

The function parameters for the Search Less Than functions are shown in the following illustration. The form of the function is the same for all Search Less Than functions; the only difference being the data type.

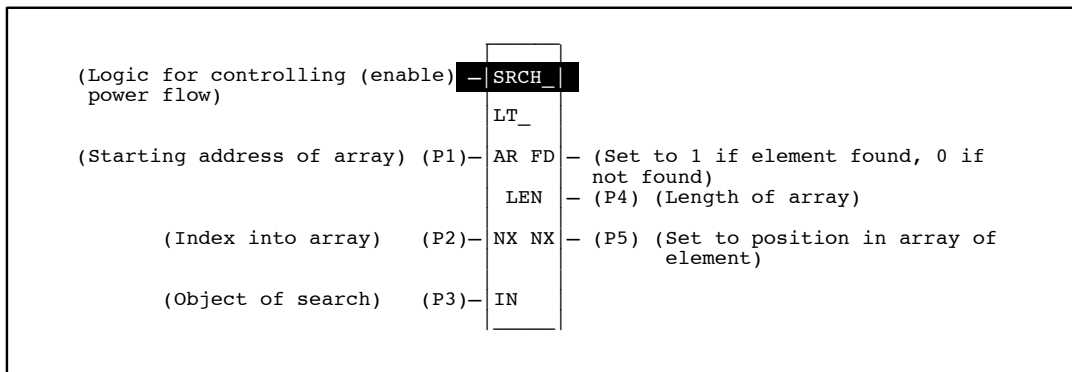

Description of Parameters for Search Less Than Functions

Parameter	Description
enable	When the function is enabled, the operation is performed.
AR(P01)	AR contains the starting address of the array to be searched.
Input NX (P02)	Input NX contains the index into the array.
IN (P03)	IN contains the object of the search.
LEN (P04)	LEN specifies the number of elements starting at AR that make up the array to be searched.
Output NX (P05)	Output NX holds the position within the array of the search target.
FD	FD indicates that an element whose value is less than IN has been found and the function was successful.

Allowable Memory Types for Search Less Than Functions

Parameter	flow	%I	%Q	%M	%T	%S	%G	%R	%AI	%AQ	const	none
enable	•											
AR		o	o	o	o	n †	o	•	•	•		
NX in		•	•	•	•		•	•	•	•		
IN		o	o	o	o	n †	o	•	•	•	•	
LEN											•	
NX out		•	•	•	•		•	•	•	•		
FD	•											•

- = Valid reference or place where power may flow through the function.
- o = Valid reference for INT, BYTE, or WORD data only; not valid for DINT.
- n = Valid reference for BYTE or WORD data only; not valid for INT or DINT.
- † = %SA, %SB, %SC only; %S cannot be used.

Search Less Than or Equal To, Byte (SRLEB) Function 113
Search Less Than or Equal To, Word (SRLEW) Function 114
Search Less Than or Equal To, INT (SRLEI) Function 115
Search Less Than or Equal To, DINT (SRLEDI) Function 116

The Search Less Than or Equal To functions are conditionally executed functions which are used to search for all array values less than or equal to a specified value.

Each function has four input parameters and two output parameters. When the function receives power, the array is searched starting at (AR + input NX). This is the starting address of the array (AR) plus the index into this array (input NX).

The search continues until the array element whose value is less than or equal to the search object (IN) is found or until the end of the array is reached. If an array element is found, the output parameter (FD) is set to true and output parameter (output NX) is set to the relative position of this element within the array. If no element is found with a value less than or equal to IN before the end of the array is reached, then output parameter (FD) is set to false and output parameter (output NX) is set to zero.

The valid values for the input NX are 0 to LEN – 1. This value increments by one at the time of execution. Therefore, the values of the output NX are 1 to LEN. If the value of the input NX is out-of-range, (< 0 or w LEN), its value is set to the default value of zero.

The function parameters for the Search Less Than or Equal To functions are shown in the following illustration. The form of the function is the same for all Search Less Than or Equal To functions; the only difference being the data type.

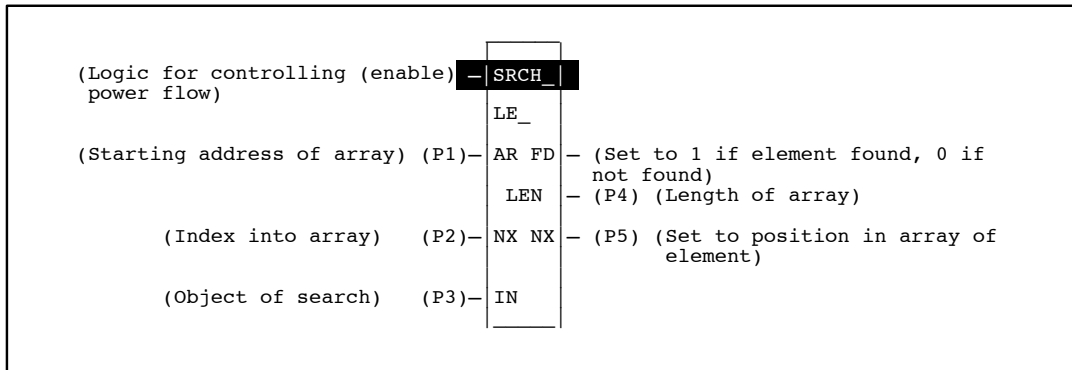

Description of Parameters for Search Less Than or Equal To Functions

Parameter	Description
enable	When the function is enabled, the operation is performed.
AR(P01)	AR contains the starting address of the array to be searched.
Input NX (P02)	Input NX contains the index into the array.
IN (P03)	IN contains the object of the search.
LEN (P04)	LEN specifies the number of elements starting at AR that make up the array to be searched.
Output NX (P05)	Output NX holds the position within the array of the search target.
FD	FD indicates that an element whose value is less than or equal to IN has been found and the function was successful.

Allowable Memory Types for Search Less Than or Equal To Functions

Parameter	flow	%I	%Q	%M	%T	%S	%G	%R	%AI	%AQ	const	none
enable	•											
AR		o	o	o	o	n †	o	•	•	•		
NX in		•	•	•	•		•	•	•	•	•	
IN		o	o	o	o	n †	o	•	•	•	•	
LEN											•	
NX out		•	•	•	•		•	•	•	•		
FD	•											•

- = Valid reference or place where power may flow through the function.
- o = Valid reference for INT, BYTE, or WORD data only; not valid for DINT.
- n = Valid reference for BYTE or WORD data only; not valid for INT or DINT.
- † = %SA, %SB, %SC only; %S cannot be used..

Search Greater Than, Byte (SRGTB) Function 117
Search Greater Than, Word (SRGTW) Function 118
Search Greater Than, INT (SRGTI) Function 119
Search Greater Than, DINT (SRGTDI) Function 120

The Search Greater Than functions are conditionally executed functions which are used to search for all array values greater than a specified value.

Each function has four input parameters and two output parameters. When the function receives power, the array is searched starting at (AR + input NX). This is the starting address of the array (AR) plus the index into this array (input NX).

The search continues until the array element whose value is greater than the search object (IN) is found or until the end of the array is reached. If an array element is found, the output parameter (FD) is set to true and output parameter (output NX) is set to the relative position of this element within the array. If no element is found with a value less than IN before the end of the array is reached, then output parameter (FD) is set to false and output parameter (output NX) is set to zero.

The valid values for the input NX are 0 to LEN – 1. This value increments by one at the time of execution. Therefore, the values of the output NX are 1 to LEN. If the value of the input NX is out-of-range, (< 0 or w LEN), its value is set to the default value of zero.

The function parameters for the Search Greater Than functions are shown in the following illustration. The form of the function is the same for all Search Greater Than functions; the only difference being the data type.

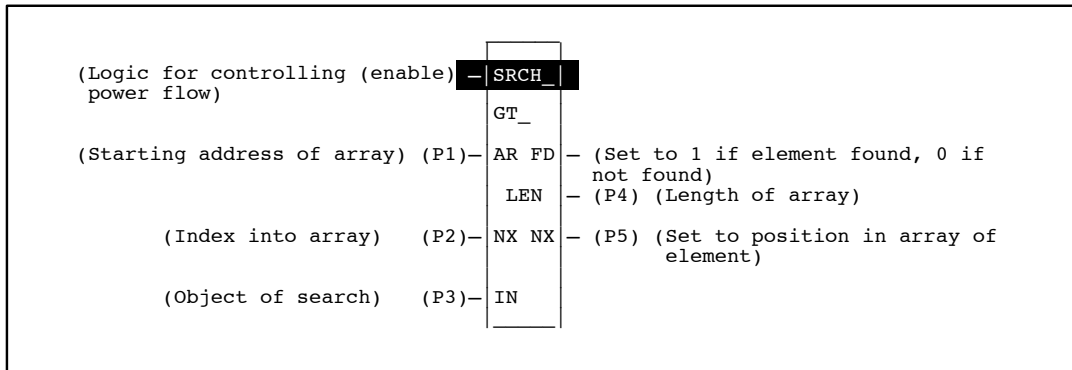

Description of Parameters for Search Greater Than Functions

Parameter	Description
enable	When the function is enabled, the operation is performed.
AR(P01)	AR contains the starting address of the array to be searched.
Input NX (P02)	Input NX contains the index into the array.
IN (P03)	IN contains the object of the search.
LEN (P04)	LEN specifies the number of elements starting at AR that make up the array to be searched.
Output NX (P05)	Output NX holds the position within the array of the search target.
FD	FD indicates that an element whose value is greater than IN has been found and the function was successful.

Allowable Memory Types for Search Greater Than Functions

Parameter	flow	%I	%Q	%M	%T	%S	%G	%R	%AI	%AQ	const	none
enable	•											
AR		o	o	o	o	n †	o	•	•	•		
NX in		•	•	•	•		•	•	•	•	•	
IN		o	o	o	o	n †	o	•	•	•	•	
LEN											•	
NX out		•	•	•	•		•	•	•	•		
FD	•											•

- = Valid reference or place where power may flow through the function.
- o = Valid reference for INT, BYTE, or WORD data only; not valid for DINT.
- n = Valid reference for BYTE or WORD data only; not valid for INT or DINT.
- † = %SA, %SB, %SC only; %S cannot be used.

Search Greater Than or Equal To, Byte (SRGEB) Function 121
Search Greater Than or Equal To, Word (SRGEW) Function 122
Search Greater Than or Equal To, INT (SRGEI) Function 123
Search Greater Than or Equal To, DINT (SRGEDI) Function 124

The Search Greater Than or Equal To functions are conditionally executed functions which are used to search for all array values greater than or equal to a specified value.

Each function has four input parameters and two output parameters. When the function receives power, the array is searched starting at (AR + input NX). This is the starting address of the array (AR) plus the index into this array (input NX).

The search continues until the array element whose value is greater than or equal to the search object (IN) is found or until the end of the array is reached. If an array element is found, the output parameter (FD) is set to true and output parameter (output NX) is set to the relative position of this element within the array. If no element is found with a value less than IN before the end of the array is reached, then output parameter (FD) is set to false and output parameter (output NX) is set to zero.

The valid values for the input NX are 0 to LEN - 1. This value increments by one at the time of execution. Therefore, the values of the output NX are 1 to LEN. If the value of the input NX is out-of-range, (< 0 or > LEN), its value is set to the default value of zero.

The function parameters for the Search Greater Than or Equal To functions are shown in the following illustration. The form of the function is the same for all Search Greater Than or Equal To functions; the only difference being the data type.

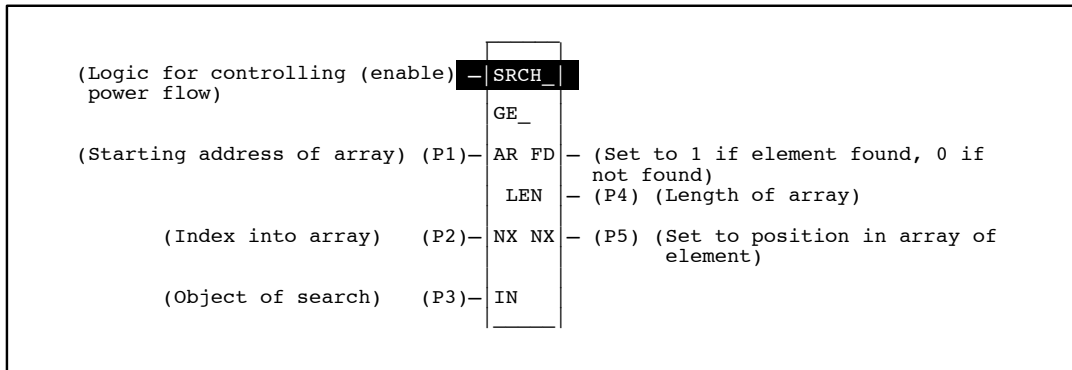

Description of Parameters for Search Greater Than or Equal To Functions

Parameter	Description
enable	When the function is enabled, the operation is performed.
AR(P01)	AR contains the starting address of the array to be searched.
Input NX (P02)	Input NX contains the index into the array.
IN (P03)	IN contains the object of the search.
LEN (P04)	LEN specifies the number of elements starting at AR that make up the array to be searched.
Output NX (P05)	Output NX holds the position within the array of the search target.
FD	FD indicates that an element whose value is greater than or equal to IN has been found and the function was successful.

Allowable Memory Types for Search Greater Than or Equal To Functions

Parameter	flow	%I	%Q	%M	%T	%S	%G	%R	%AI	%AQ	const	none
enable	•											
AR		o	o	o	o	n †	o	•	•	•		
NX in		•	•	•	•		•	•	•	•	•	
IN		o	o	o	o	n †	o	•	•	•	•	
LEN											•	
NX out		•	•	•	•		•	•	•	•		
FD	•											•

- = Valid reference or place where power may flow through the function.
- o = Valid reference for INT, BYTE, or WORD data only; not valid for DINT.
- n = Valid reference for BYTE or WORD data only; not valid for INT or DINT.
- † = %SA, %SB, %SC only; %S cannot be used.

Programming Examples for Array Search Functions

The following programming examples illustrate how to enter the Search Equal To Byte (SREQB) and Search Equal To Integer (SREQI) functions on the HHP. The ladder diagram representation of the example is shown, followed by the equivalent HHP statement list and the key sequences required to enter the statement list.

Example 1: Byte Array Search Equal To

In this example, the array AR is defined as memory addresses %I1 to %I40. When %I99 closes (passes power flow to the enable input), the portion of the array between %I17 and %I40 will be searched for an element whose value is equal to IN. If %I1 to %I8 = 1, %I9 to %I16 = 9, %I17 to %I24 = 11, %I25 to %I32 = 19, %I33 to %I40 = 21, and %M5 = 19 then the search will begin at %I17 to %I24 and conclude at %I25 to %I32 when FD will be set to true and a 4 (the array index) will be written to %Q41 to %Q48.

Ladder Diagram Representation

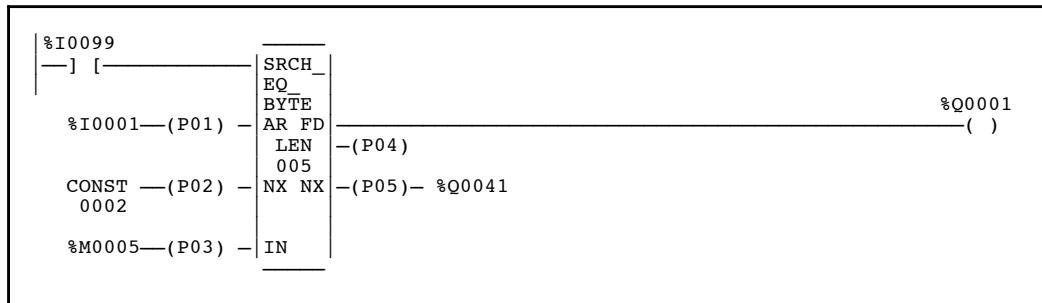

Statement List Representation

```

#0001: LD %I0099
#0002: FUNC 101 SREQB
          P01: %I0001
          P02: 2
          P03: %M0005
          P04: 5
          P05: %Q0041
#0003: OUT %Q0001
  
```

After pressing  key: Programming sequence

Key Strokes

HHP Display

Initial display:

```
#0001  INS  <S  
_
```

Press the key sequence

    :

```
#0001  INS  <S  
LD    I 99_
```

Press the  key:

```
#0002  INS  <S  
_
```

Press the key sequence

    :

```
#0002  INS  <S  
FUNC  101_SREQB
```

Press the  key:

```
#0002  SREQB <S  
P01  _
```

Press the key   sequence :

```
#0002  SREQB <S  
P01 I 1_
```

Press the  key:

```
#0002  SREQB <S  
P02  _
```

Press the  key:

```
#0002  SREQB <S  
P02  2_
```

Press the  key:

```
#0002  SREQB <S  
P03  _
```

Press the key   sequence :

```
#0002  SREQB <S  
P03 M 5_
```

Press the  key:

```
#0002  SREQB <S  
P04  _
```



Press the  key:

```
#0002  SREQB <S  
P04  5_
```

Press the  key:

```
#0002  SREQB <S  
P05  _
```

Press the key sequence

   :

```
#0002  SREQB <S  
P05 Q 41_
```

Press the  key:

```
#0003  INS  <S  
_
```

Press the key sequence

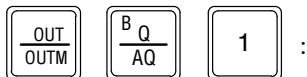

```
#0005  INS  <S
OUT      Q  1_
```

Press the  key:

```
#0006  INS  <S
_
```

Example 2: Integer Array Search Equal To

In this example, the array AR is defined as memory addresses %R1 to %R5. When %I1 closes (passes power flow to the enable input), the portion of the array between %R3 and %R5 will be searched for an element whose value is equal to IN. If %R1 = 7, %R2 = 9, %R3 = 6, %R4 = 7, %R5 = 7, and %R100 = 7, then the search will begin at %R3 and conclude at %R4 when FD will be set to true and a 4 (the array index) will be written to %R101.

Ladder Diagram Representation

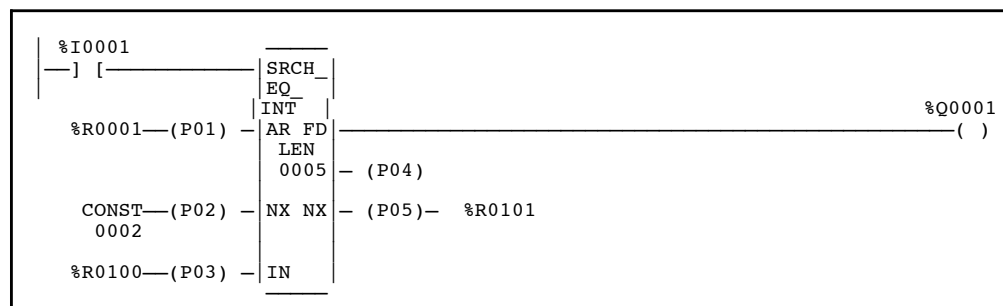

Statement List Representation

```
#0001:  LD      %I0001
#0002:  FUNC    103  SREQI
          P01:  %R0001
          P02:  2
          P03:  %R0100
          P04:  5
          P05:  %R0101
#0003:  OUT    %Q0001
```

After pressing the:  Key: Programming sequence

Key Strokes

HHP Display

Initial display:

```
#0001  INS  <S
_
```

Press the key sequence

```
LD   1 :
```

```
#0001  INS  <S
LD      I 1_
```

Press the  key:

```
#0002  INS  <S
LD      I 1_
```

Press the key sequence

```
FUNC 1 0 3 :
```

```
#0002  INS  <S
FUNC 103_SREQI
```

Press the  key:

```
#0002  SREQI <S
P01  _
```

Press the key sequence

```
R 1 :
```

```
#0002  SREQB <S
P01 R 1_
```

Press the  key:





```
#0002  SREQI <S
P02  _
```

Press the  key:

```
#0002  SREQI <S  
P02   2_
```

Press the  key:

```
#0002  SREQI <S  
P03  _
```

Press the key sequence
    :

```
#0002  SREQI <S  
P03 R  100_
```

Press the  key:





```
#0002  SREQI <S  
P04  _
```

Press the  key:

```
#0002  SREQI <S  
P04   5_
```

Press the  key:

```
#0002  SREQI <S  
P05  _
```

Press the key sequence
    :

```
#0002  SREQI <S  
P05 R  101_
```

Press the  key:

```
#0003  INS  <S  
_
```

Press the key sequence

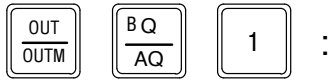

Press the



key:

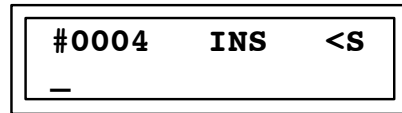

Array Move Functions

The Array Move functions are used to copy a specified number of data elements from a source array to a destination array. The Array Move functions can each operate on bit, byte, word, integer, or double precision data types. Each of the Array Move functions and their respective function numbers are listed in the following table.

Array Move Functions

Array Move Data Type	Abbreviation	Function Number
Bit	MOVABI	130
Byte	MOVABY	131
Word	MOVAW	132
Integer(INT)	MOVAI	133
Double Precision Integer (DINT)	MOVADI	134

Array Move, Bit (MOVABI) Function 130
Array Move, Byte (MOVABY) Function 131
Array Move, Word (MOVAW) Function 132
Array Move, INT (MOVAI) Function 133
Array Move, DINT (MOVADI) Function 134

The Array Move function has six input parameters and two output parameters. When the function receives power flow to the enable input, the function is executed by the CPU and the number of data elements in the count indicator (N) is extracted from the input array starting with the indexed location (SR + SNX - 1). The data elements are then written to the output array starting with the indexed location (DS + DNX - 1). The LEN operand specifies the number of elements that make up each array.

For the Bit Array Move function, when word-oriented memory is selected for the parameters of the source array and/or destination array starting address, the least significant bit of the specified word is the first bit of the array. The value displayed contains 16 bits, regardless of the length of the array.

The ok output will receive power flow unless one of the following conditions occurs:

- Enable is false.
- (N + SNX) is greater than (SR + LEN).
- (N + DNX) is greater than (DS + LEN).

The function parameters for the Array Move functions are shown in the following illustration. The form of the function is the same for all Array Move functions; the only difference being the data type.

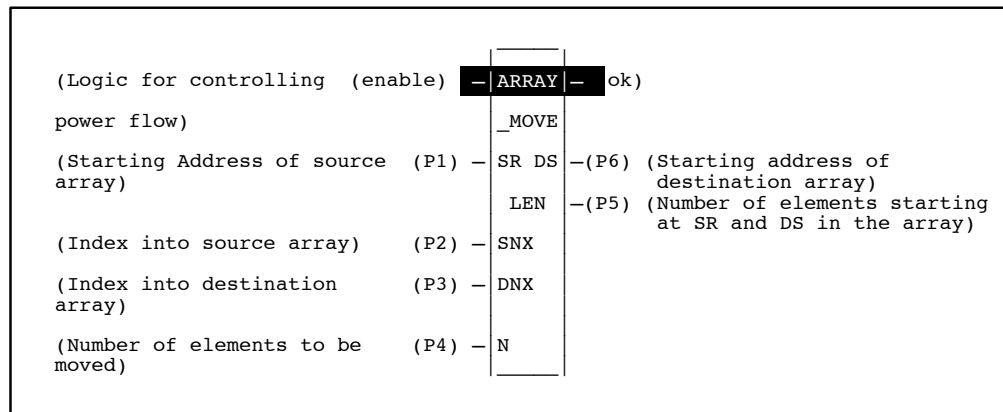

Parameters for Array Move Functions

Parameter	Description
enable	When the function is enabled, the operation is performed.
SR (P01)	SR contains the starting address of the source array. For Bit Array Move, any discrete reference may be used; it does not need to be byte aligned. However, 16 bits, beginning with the reference address specified, are displayed online.
SNX (P02)	SNX contains the index of the source array.
DNX (P03)	DNX contains the index of the destination array.
N (P04)	N provides a count indicator of number of elements to be moved.
LEN (P05)	LEN specifies the number of elements starting at SR and DS that make up each array.
DS (P06)	DS contains the starting address of the destination array. For Bit Array Move, any discrete reference may be used; it does not need to be byte aligned. However, 16 bits, beginning with the reference address specified, are displayed online.
ok	The ok output is energized whenever the function is enabled.

Allowable Memory Types for Array Move Functions

Parameter	flow	%I	%Q	%M	%T	%S	%G	%R	%AI	%AQ	const	none
enable	•											
SR		o	o	o	o	Δ†	o	•	•	•		
SNX		•	•	•	•		•	•	•	•	•	
DNX		•	•	•	•		•	•	•	•	•	
N		•	•	•	•		•	•	•	•	•	
LEN											•	
DS		o	o	o	o	†	o	•	•	•		
ok	•											•

• = Valid reference or place where power may flow through the function. For Bit Array Move, discrete user references %I, %Q, %M, and %T need not be byte aligned.

o = Valid reference for INT, BIT, BYTE, or WORD data only; not valid for DINT.

Δ = Valid data type for BIT, BYTE, or WORD data only; not valid for INT or DINT.

† = %SA, %SB, %SC only; %S cannot be used.



After pressing the:  Key: Programming sequence

Key Strokes

HHP Display

Initial display:





```
#0001  INS  <S  
_
```

Press the key sequence
   :

```
#0001  INS  <S  
LD      I 1_
```

Press the  key:



```
#0002  INS  <S  
_
```

Press the key sequence
    :

```
#0002  INS  <S  
FUNC  130_ MOVABI
```

Press the  key:

```
#0002  MOVABI <S  
P01  _
```

Press the key sequence
  :

```
#0002  MOVABI <S  
P01 M 9_
```

Press the  key:

```
#0002  MOVABI <S  
P02  _
```

Press the  key:

```
#0002  MOVABI <S  
P02    3_
```

Press the  key:

```
#0002  MOVABI <S  
P03    _
```

Press the  key:

```
#0002  MOVABI <S  
P03    5_
```

Press the  key:

```
#0002  MOVABI <S  
P04    _
```

Press the  key:

```
#0002  MOVABI <S  
P04    7_
```

Press the  key:

```
#0002  MOVABI <S  
P05    _
```

Press the key sequence:

 

```
#0002  MOVABI <S  
P05    16_
```

Press the  key:

```
#0002  MOVABI <S  
P06    _
```

Press the key sequence

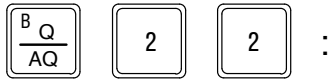

```
#0002  MOVABI <S  
P06 Q  22_
```

Press the  key:

```
#0003  INS  <S  
_
```

Press the key sequence

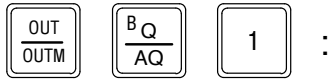

```
#0003  INS  <S  
OUT      Q 1_
```

Press the  key:

```
#0004  INS  <S  
_
```

Example 2: Byte Array Move

In this example, when input %I0001 is closed (passes power flow to the enable input), the function is executed. Bit memory is used for the SR and DS inputs; %I0017 to %I32 of the array %I0001 to %I0040 is read and then written into the destination %Q0041 to %Q0056 of the array %Q0041 through %Q0080.

Ladder Diagram Representation

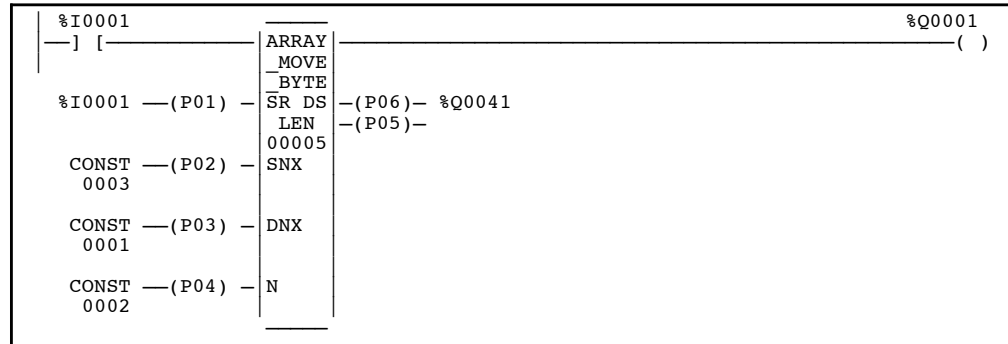

Statement List Representation

```

#0001: LD %I0001
#0002: FUNC 131 MOVABY
      P01: %I0001
      P02: 3
      P03: 1
      P04: 2
      P05: 5
      P06: %Q0041
#0003: OUT %Q0001
  
```

After pressing the: INS Key: Programming sequence

Key Strokes

HHP Display

Initial display:

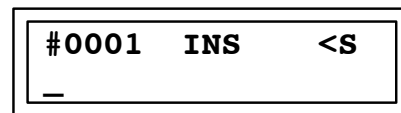



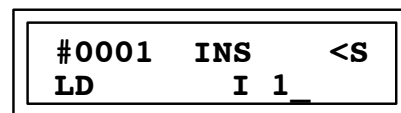

Press the key sequence

LD A1/A1 1 :



Press the  key:



```
#0002  INS  <S  
_
```

Press the key sequence
    :

```
#0002  INS  <S  
FUNC  131_ MOVABY
```

Press the  key:

```
#0002 MOVABY <S  
P01  _
```

Press the key sequence
  :

```
#0002  MOVABY <S  
P01 I 1_
```

Press the  key:

```
#0002  MOVABY <S  
P02  _
```

Press the  key:

```
#0002  MOVABY <S  
P02   3_
```

Press the  key:

```
#0002  MOVABY <S  
P03  _
```

Press the  key:

```
#0002  MOVABY <S  
P03   1_
```

Press the  key:

```
#0002  MOVABY <S
P04  _
```

Press the  key:

```
#0002  MOVABY <S
P04  2_
```

Press the  key:

```
#0002  MOVABY <S
P05  _
```



Press the  key:

```
#0002  MOVABY <S
P05  5_
```

Press the  key:

```
#0002  MOVABY <S
P06  _
```

Press the key sequence



   :

```
#0002  MOVABY <S
P06 Q 41_
```

Press the  key:

```
#0003  INS  <S
_
```

Press the key sequence

   :

```
#0003  INS  <S
OUT      Q 1_
```

Press the  key:

```
#0004  INS  <S
_
```

Example 3: Word Array Move

In this example, when input %I0001 is closed (passes power flow to the enable input), the function is executed. Word memory is used for the SR and DS inputs; %R0003 through %R0007 of the array %R0001 through %R0016 is read and then written to the destination %R0104 through %R0108 of the array %R0100 through %R0115.

Ladder Diagram Representation

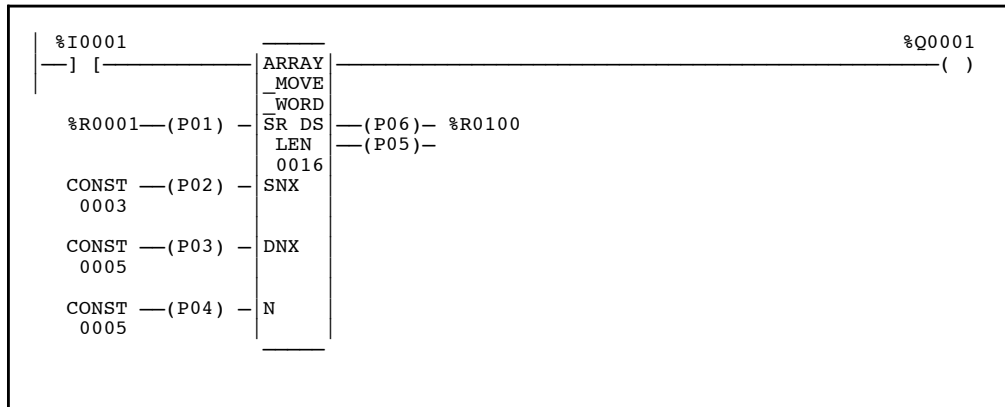

Statement List Representation

#0001:	LD		%I0001
#0002	FUNC	132	MOVAW
		P01:	%M0001
		P02:	3
		P03:	5
		P04:	5
		P05:	16
		P06:	%R0100
#0003:	OUT		%Q0001

After pressing  key: Programming sequence



Key Strokes

HHP Display

Initial display:

```
#0001  INS  <S
_
```

Press the key sequence



   :

```
#0001  INS  <S
LD      I 1_
```

Press the  key:

```
#0002  INS  <S
_
```



Press the key sequence

    :

```
#0002  INS  <S
FUNC  132_ MOVAW
```

Press the  key:

```
#0002  MOVAW <S
P01  _
```

Press the key sequence   :

```
#0002  MOVAW <S
P01 R 1_
```

Press the  key:

```
#0002  MOVAW <S
P02  _
```

Press the  key:

```
#0002  MOVAW  <S  
P02  _ 3_
```

Press the  key:

```
#0002  MOVAW  <S  
P03  _
```

Press the  key:

```
#0002  MOVAW  <S  
P03  5_
```

Press the  key:



```
#0002  MOVAW  <S  
P04  _
```

Press the  key:

```
#0002  MOVAW  <S  
P04  5_
```

Press the  key:

```
#0002  MOVAW  <S  
P05  _
```

Press the key sequence   :

```
#0002  MOVAW  <S  
P05  16_
```

Press the  key:

```
#0002  MOVAW  <S  
P06  _
```

Press the key sequence

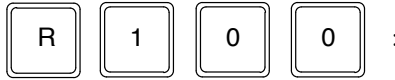

```
#0002  MOVAW  <S  
P06 R 100_
```

Press the  key:

```
#0003  INS    <S  
_
```

Press the key sequence

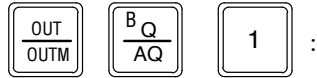

```
#0003  INS    <S  
OUT      Q 1_
```

Press the  key:

```
#0004  INS    <S  
_
```

Chapter 10

Error Messages

This chapter does not apply to the CPU 351.

This chapter summarizes the non-system error messages and/or displays which may occur during the operation of the Hand-Held Programmer. Non-system errors are those errors that the system detects in user-provided data. They may be caused by an illegal sequence of otherwise valid individual instructions. Typical examples of these errors include:

- JUMP, MCR, or CEND nesting errors.
- The use of more than 256 total JUMP and MCR functions.
- The placement of an ENDSW function within a JUMP or MCR range.
- Incorrect instruction sequences.
- The dual use of %Q or %M references. (This prompts a warning only.)
- Corrupted memory (unknown instructions).

These errors are scanned for when the program check function is initiated. This function is automatically performed whenever the operating state of the PLC is changed from stopped to running.

To manually check a logic program for non-system errors, enter the following key sequence, in the order shown:

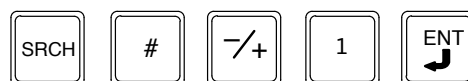

When initiated, the program check function always begins at the start of the program and stops with the first error found. If no errors are found, the current instruction step remains displayed and no message is displayed. The following table lists non-system errors and the corrective action required for each error.

Table 10-1. Non-System Errors

Error	Description	Corrective Action
CEND ERR	Improper nesting of JUMP, MCR, and/or CEND functions. The instruction step shown is where the error was detected.	Correct the program logic to eliminate the improper nesting.
I/O ERR	Overlap of I or AI references between two slot configurations.	Eliminate the input address overlap from the configuration.
DATA ERR	Specification of a constant, reference address, or function number which is out of the range of acceptable values.	Change the constant, reference address, or function number to an acceptable value.

Table 10-1. Non-System Errors - continued

Error	Description	Corrective Action
NOT FND	Specification of a search target which was not found within the existing program logic.	No action is required.
REF ADJ	Specification of a reference address which was not on an acceptable boundary for a particular function parameter	The system automatically adjusted the reference address to an acceptable boundary. No further action is required.
MEM OVR	Attempted to accept additional program logic instruction steps without sufficient user program memory remaining. Attempted to exceed the 16K bytes available per subroutine block.	Abort the current instruction step insert or edit operation. Examine logic and redo as necessary.
PROTECT	Attempted an operation without the proper privilege level, or attempted to program a write-protected Memory Card Attempt made to view or edit a locked subroutine.	Use protection mode to change the privilege level to the proper setting, or remove the write protect from the Memory Card. Remove locked status using Logicmaster 90-30 (cannot be removed with the HHP).
RUNNING	Attempted an operation which is not valid when the PLC is running.	Stop the PLC; then perform the operation again.
INS ER	Attempted to accept an incomplete or invalid instruction.	Complete or correct the instruction; then, press the ENT key again.
REPL CER	Attempted to make an illegal on-line substitution change.	Make a correct substitution change, or cancel the substitution change request.
STK OVR	Created an instruction sequence whose stack depth usage exceeds 9.	Change the instruction sequence so that the stack depth usage is less than or equal to eight.
SEQ ERR	Created an invalid instruction sequence.	Correct the instruction sequence to make it valid.
USE WRN	Dual use of a %Q or %M reference as an output exists in the program.	This message is a warning only; you must decide if it is an error. Use the program check function to verify that there are multiple coil usages.
USE ERR	Attempt to reuse a %Q or %M reference as an output with dual use checking enabled.	Choose a different reference address which has not been used previously, or disable dual use checking and program the instruction step again.
PSW ERR	Specifying a password or OEM key which is incorrect for the indicated access level.	Specify the correct password or OEM key.
IOM ER	Specification of an invalid module type for the configuration of a slot.	Specify the valid module type.
ID ERR	Specification of an invalid board or module ID for generic configuration.	Specify a valid board or module ID.
ROM ERR	Failure attempting to read or write EEPROM.	This failure typically occurs when the EEPROM chip is either not installed or not installed properly. Install the chip (or a new one), and try again.
VRFY ER	Verification of RAM contents against either EEPROM or the MEM CARD contents failed due to mismatches.	You must decide if the verification failure is expected or not.

Table 10-1. Non-System Errors - continued

Error	Description	Corrective Action
NO CARD	Attempted a read, write, or verify operation with the MEM CARD when it was not inserted in the HHP slot.	Insert the MEM CARD into the Hand-Held Programmer slot, and perform the operation again.
COMMER	Communications error during a read, write, or verify operation with the MEM CARD.	Make sure that the MEM CARD is inserted properly into the HHP slot, and perform the operation again.
RETN WRN	The last instruction entered changed the retentive nature of its operand.	This message is a warning only. The user must decide whether it is an error or is OK.
FROZEN	Intelligent module's previous configuration being used.	Press WRITE and ENT keys to complete editing of new parameters.
REFER	Invalid reference type entered	Refer to the appropriate section of this manual to determine the valid reference type for the instruction you are entering and choose one.
PRG ERR	Read or Verify of the program from / with EEPROM / Mem Card	Correct invalid logic; ensure that program is consistent with the model of PLC.
NEST ERR	Exceeded CALLSUB nesting level limitation of 8. This error is displayed when you try to zoom into the ninth (illegally nested) subroutine in the CALLSUB sequence. If no zoom is attempted, the error will be logged as a fault at runtime.	Remove CALLSUB instruction(s) which caused the illegal nesting sequence.
CFG ERR	Read or Verify of the Config from / with EEPROM / Mem Card	Ensure that Config matches the Config in the PLC; verify that the PLC model is correct.
ZOOMER	Attempted to zoom into an instruction that is not a CALLSUB.	Locate the CALLSUB instruction you wish to zoom into and retry the # → key sequence.
CALL OVR	Exceeded the 64 CALLSUB instruction per logic block limit.	Abort the current instruction step insert or edit operation.

This Appendix is a Glossary of Terms for the Hand-Held Programmer and the Series 90-30, Series 90-20, and Series 90 Micro PLCs.

Glossary of Terms for the Series 90-30/20/Micro PLCs

Address

A number following a reference type which together refer to a specific user reference, that is, for %Innnn; %I is the reference type and nnnn is the address.

Alarm Processor

A software function that time-stamps and logs I/O and system faults in two tables that can be displayed by the programmer or uploaded to a host computer or other coprocessor.

Analog

An electrical signal activated by physical variables representing force, pressure, temperature, flow, etc.

AND (Logical)

A mathematical operation between bits. All bits must be 1 for the result to be 1.

Application Program

The program written by the user for control of a machine or process, that is the application.

ASCII

American Standard Code for Information Interchange. An eight-bit (7 bits plus 1 parity bit) code used for data.

Backplane

A group of connectors physically mounted on a board at the back of a rack into which modules are inserted. The connectors are wired together by a printed circuit board.

Baseplate

A frame containing the backplane for the system bus and connectors into which modules are inserted. In the Series 90-30 PLC Model 311 and Model 313, the baseplate also contains the CPU.

Battery Connector

A connector wired to a Lithium battery which connects the battery to the CMOS RAM memory devices by being plugged into a receptacle accessed via a door on the power supply faceplate.

Baud

A unit of data transmission. Baud rate is the number of bits per second transmitted.

Bit

The smallest unit of memory. Can be used to store only one piece of information that has two states (for example One / Zero, On / Off, Good / Bad, Yes / No). Data that requires more than two states (for example numerical values 000 to 999) requires multiple bits (see Word).

Bus

An electrical path for transmitting and receiving data.

Byte

A group of binary digits operated on as a single unit. In the Series 90-30 and Series 90-20 PLCs, a byte is eight bits.

Circuit Wiring Diagram

Field wiring information that provides a guide to users for connecting field devices to input and output modules. Each I/O module has a circuit wiring diagram printed on the inside surface of an insert in the module's hinged door.

CONFIG.SYS File

A file that describes the system requirements for the software. The CONFIG.SYS file must be custom-tailored to fit the specific hardware configuration of your system and Logicmaster 90 requirements.

Constant

A fixed value or an item of data that does not vary. Can be stored in a register.

Counter

A function block which can be programmed to control other devices according to a preset number of on/off transitions.

CPU (Central Processing Unit)

The central device or controller that interprets user instructions, makes decisions, and executes the functions based on a stored application program.

Data Memory

User references within the Series 90-30 and 90-20 PLC CPU which are accessible by the application program for storage of discrete or register data.

Data Table

A consecutive group of user references of the same size accessed with table read/write functions.

Discrete

The term "discrete" includes both real and internal I/O that are one-bit user references.

Expansion Baseplate

A 5-slot or 10-slot baseplate added to a Series 90-30 PLC Model 331, Model 340, Model 341, or Model 351 system when the application calls for more modules than the main baseplate can contain. A Series 90-30 PLC Model 331, Model 340, Model 341, or Model 351 system can have up to 4 expansion baseplates.

Expansion Cable

A cable which propagates the parallel I/O bus signals between expansion baseplates. The total length of all expansion cables, from the main baseplate to the last expansion baseplate in a system, can be no more than 50 feet (15 meters) in a local expansion system or 700 feet (213 meters) in a remote expansion system.

Firmware

A series of instructions contained in ROM (Read Only Memory) which are used for internal processing functions. These instructions are transparent to the user.

Grounding Terminal

A terminal on each power supply which must be connected to earth ground (through the AC power source) to ensure that the rack is properly and safely grounded.

Hardware

All of the mechanical, electrical, and electronic devices that comprise the Series 90-30 PLC and its applications.

Hexadecimal

A numbering system, having 16 as a base, represented by the digits 0 through 9, then A through F.

Hinged Door

A plastic door on the front of a module which, when open, allows access to certain module hardware features.

Input Module

An I/O module that converts signals from user devices to logic levels that can be used by the CPU.

Input Scan Time

The time required for the CPU to scan all I/O controllers for new input values. When model 30 I/O is present, this includes the time to actually read each module.

I/O (Input/Output)

That portion of the PLC to which field devices are connected and which isolates the CPU from electrical noise.

I/O Electrical Isolation

A method of separating field wiring from logic level circuitry. Typically, this is accomplished through use of solid-state optical isolation devices.

I/O Fault Table

A fault table listing I/O faults. These faults are identified by time, date, and location.

I/O Module

A printed circuit assembly that interfaces between user devices and the Series 90-30 PLC.

K

An abbreviation for kilo or exactly 1024 in the language of computers.

Ladder Diagram

A graphic representation of combinational logic.

LED Status Display

A display consisting of a group of LEDs with two rows of eight LEDs at the top of each discrete I/O module. Each LED in the two groups of eight indicates the state of the respective input or output point on the board.

Link

Horizontal and vertical links are used to carry power around an element in a ladder logic program, or to place elements in parallel or series with one another.

List

A group of consecutive storage locations in memory, used for data manipulation. The beginning address and length of the list are set up in the user program. Data is accessed from either the top or the bottom of the list.

Logic Solution Time

The time required to execute all active instructions in the application program.

Main Baseplate

The baseplate in a Series 90-30 PLC system in which the CPU is installed. This rack must always be included in a system and is always rack number "0".

Memory Card

A memory cartridge containing EEPROM memory which is inserted into a slot in the Hand-Held Programmer. This memory cartridge, provides the Hand-Held Programmer with a means for off-line storage and retrieval of the application program and system configuration data.

Microsecond (μ s)

One millionth of a second. 1×10^{-6} or 0.000001 second.

Millisecond

One thousandth of a second. 1×10^{-3} or 0.001 second. May be abbreviated as ms.

Mnemonic

An abbreviation given to an instruction; usually an acronym formed by combining initial letters or parts of words.

Model 30 I/O

The Series 90-30 I/O subsystem consisting of discrete, analog, and intelligent input and output modules.

Module

A replaceable electronic subassembly usually plugged into connectors on a backplane and secured in place, but easily removed in case of a failure or system redesign. In the Series 90-30 PLC, a combination of a printed circuit board and its associated faceplate (and removable terminal connector, on I/O modules) which, when combined, form a complete assembly.

Molded Hinge

A hinge at the top rear of each Model 30 I/O module type which, when the module is installed, latches onto the top of the baseplate. This hinge helps to keep the module securely in place.

Noise

Undesirable electrical disturbances to normal signals, generally of high frequency content.

Non-Retentive Coil

A coil that will turn off upon removal of applied power to the CPU.

Non-Volatile Memory

A memory (for example PROM) capable of retaining its stored information under no-power conditions (power removed or turned off).

OR (Logical)

A logical operation between bits, whereby if any bit is a 1, the result will be a 1.

Output

Data transferred from the CPU, through a module for level conversion to be used for controlling an external device or process.

Output Devices

Physical devices such as motor starters, solenoids, etc. that are switched by the PLC.

Output Module

An I/O module that converts logic level signals within the CPU to usable output signals for controlling a machine or process.

Output Scan Time

The time required for the CPU to update all I/O controllers with new output values. When Model 30 I/O is present, this includes the time to actually write to each module.

Panel Mounting Flange

Flanges, with mounting holes, on the sides of a baseplate used to mount the baseplate on an electrical panel or wall.

Parallel Communication

A method of data transfer whereby data is transferred on several wires simultaneously.

Parity

The anticipated state, either odd or even, of a set of binary digits.

Parity Bit

A bit added to a memory word to make the sum of the bits in a word always even (even parity) or always odd (odd parity).

Parity Error

A condition that occurs when a computed parity check (checksum) does not agree with the parity bit.

Peripheral Equipment

External devices that can communicate with a PLC; for example, programmers, printers, etc.

PLC Fault Table

A fault table listing PLC faults. These faults are identified by time, date, and location.

Power Flow

In a ladder diagram, the symbolic flow of power represents the logical execution of program functions. For each function, it is important to know what happens when power is received and under what conditions power flow is output.

Preset Value

A numerical value specified in a function which establishes a limit for a counter or timer.

Program Block

A unit of an application program. It contains the control logic and certain overhead data. This program block can have up to 8K words, including logic and overhead.

Program Sweep Time

The time from the start of one cycle of the application program to the next. The program sweep is composed of the following: perform start of sweep system tasks, read the inputs, execute the user's program, write the outputs, recover faulted boards, complete minimal checksum calculation, schedule the next sweep, communicate with the programmer and other intelligent option modules, and execute background tasks.

Programmable Logic Controller (PLC)

A solid-state industrial control device which receives signals from user supplied control devices such as switches and sensors, implements them in a precise pattern determined by ladder diagram based application programs stored in user memory, and provides outputs for control of processes or user supplied devices such as relays or motor starters. It is usually programmed in relay ladder logic and is designed to operate in an industrial environment.

Programmer

The hardware device required to run Logicism 90 software. A Workstation Interface board must be installed in the programmer to communicate with the Series 90-30 PLC.

Programmer Port

The serial port on the power supply module, accessible through a 15-pin connector, to which the programmer must be connected in order to communicate with the PLC. Both the Logicism 90 programmer and the Hand-Held Programmer connect to this port.

PROM

An acronym for Programmable Read Only Memory, which is a retentive digital device programmed at the factory and not easily changed by the user. Usually contains programs for internal system use.

Rack

A Series 90-30 baseplate when it has modules installed in it.

Rack Number

A unique number, from 0 to 4, assigned to a Series 90-30 Model 331, Model 340, Model 341, or Model 351 baseplate for rack identification purposes. The main baseplate is always rack 0.

Rack Number DIP Switch

A DIP three-position DIP switch located on the backplane directly behind the power supply which must be configured to select a unique rack number from 1 to 4 for Series

90-30 PLC Model 331, Model 340, Model 341, or Model 351 expansion racks. Rack numbers cannot be duplicated in a system.

RAM

An acronym for Random Access Memory, which is a solid-state memory that allows individual bits to be stored and accessed at random. This memory stores the Logicmaster software, program files, and related data while power is applied to the system. This type of memory, however, is volatile. Because data stored in RAM is lost under no-power conditions, a backup battery is required to retain the contents under those conditions. The Series 90-30 PLC uses a long-life Lithium battery mounted on the Power Supply and PCM modules.

Read

To have data entered or to extract data from a storage device.

Release Lever

A molded lever on the bottom of each Model 30 I/O module, which when depressed upwards, releases the module in its slot to allow removal of the module.

Reference Type

A specific group of memory types in the Series 90-30 and Series 90-20 PLC, for example, %I references discrete inputs and %Q references discrete outputs. The % symbol is used to distinguish machine references from nicknames.

Register

A group of 16 consecutive bits in register memory, referenced as %R. Each register is numbered, beginning at 0001. Register memory is used for temporary storage of numerical values, and for bit manipulation.

Removable Terminal Connector

The removable assembly which attaches to the front of a printed wire board, and contains the screw terminals to which field wiring is connected.

Restart Pushbutton

A pushbutton on the front of the PCM used to reinitialize the PCM or to initiate a hard or soft reset.

Retentive Coil

A coil that will remain in its last state, even though power has been removed.

RUN Mode

A condition or state of the PLC where the CPU executes the application program. RUN mode executes in the RUN / OUTPUTS ENABLED mode only. In RUN / OUTPUTS ENABLED, all portions of the program sweep are executed.

Rung

A unit of ladder logic. One rung may have up to eight parallel lines of logic connected to the left rail, but these must be combined so that there is just one connection to the right rail.

Serial Communication

A method of data transfer whereby the bits are handled sequentially rather than simultaneously as in parallel data transmission.

Serial Port

The port on the power supply module, accessible through a 15-pin connector, to which the programmer must be connected in order to communicate with the PLC. Both the LogiMaster 90 programmer and the Hand-Held Programmer connect to this port.

Significant Bit

A bit that contributes to the precision of a number. The number of significant bits is counted beginning with the bit contributing the most value, referred to as the Most Significant Bit (MSB), and ending with the bit contributing the least value, referred to as the Least Significant Bit (LSB).

STOP Mode

A condition or state of the Series 90-30 PLC where the CPU no longer executes the application program. STOP mode can either be STOP/OUTPUTS DISABLED or STOP/OUTPUTS ENABLED. In STOP/OUTPUTS DISABLED mode, the PLC only communicates with the programmer and other devices (GBC, PCM, etc.), recovers faulted boards, reconfigures boards and executes background tasks. All other portions of the sweep are skipped. In STOP/OUTPUTS ENABLED mode, the PLC CPU can monitor I/O. This feature provides a way to monitor and debug I/O without actually executing the application program.

Storage

Used synonymous with memory.

Sweep

The CPU's repeated execution of all program logic, I/O service, peripheral service, and self-testing. This occurs automatically, many times each second.

Termination Resistor Pack

A resistor pack used to properly terminate the I/O bus signals; physically installed inside of the terminator plug.

Terminator Plug

A plug containing a resistor pack which must be installed at the end of the I/O bus chain to properly terminate the I/O bus signals. In a Series 90-30 Model 331, Model 340, and

Model 341 PLC system, this plug must be installed on the unused connector on the last I/O expansion cable in the I/O bus chain.

Timer

A function block that can be used to control the operating cycle of other devices by a preset and accumulated time interval.

User Memory

The portion of system memory in which the application program and data is stored. This memory is battery-backed CMOS RAM.

User Reference Type

A reference assigned to data which indicates the memory in which it is stored in the PLC. References can be either bit-oriented (discrete) or word-oriented (register).

Verify

A function used to compare program configuration and reference data between the CPU and memory card or EEPROM.

Volatile Memory

A type of memory that will lose the information stored in it if power is removed from the memory devices. Requires a backup battery for retention of contents of memory. In the Series 90-30 PLC a Lithium battery is used for this purpose.

Watchdog Timer

A timer in the CPU used to ensure that certain hardware conditions are met within a predetermined time. The watchdog timer value in the Series 90-30 PLC is 200 milliseconds.

Word

A measurement of memory length, usually 4, 8, or 16-bits long; in the Series 90 PLCs, a word is 16-bits in length.

Write

To transfer, record, or copy data from one storage device to another, for example, from CPU to memory card or EEPROM.

Glossary of Basic Instructions and Reference Types for Logicmaster 90-30/20/Micro Software Developed Programs

Basic Instruction	Specific Term	Generic Term
--] [--	normally open contact	contact
--]/ [--	normally closed contact	contact
--()--	coil	coil
--(/)--	negated coil	coil
--(SET)--	SET coil	coil
--(R)--	RESET coil	coil
--(↑)--	positive transition coil	coil
--(↓)--	negative transition coil	coil
--(M)--	retentive coil	coil
--(/M)--	negated retentive coil	coil
--(SM)--	retentive SET coil	coil
--(RM)--	retentive RESET coil	coil
-----	horizontal link	link
	vertical link	link

Reference Type	Specific Term	Generic Term
%I	input	discrete
%Q	output	discrete
%M	internal	discrete
%T	temporary	discrete
%G	global	discrete
%S	system	discrete
%SA	system	discrete
%SB	system	discrete
%SC	system	discrete
%R	register	register
%AI	analog input register	register
%AQ	analog output register	register
%Rnnnn	nnnn is the address	

Appendix B

Special Contact References

In the Series 90-30 and 90-20 programmable logic controllers, 128 bits of discrete storage are reserved for special contact references. These references are addressed in four groups:

1. %S0001 - %S0032.
2. %SA001 - %SA032.
3. %SB001 - %SB032.
4. %SC001 - %SC032.

The meaning for each of the 128 system references is listed in the following tables.

Special Contact References	
Reference Address	Reference Description
%S0001	Current sweep is the first sweep.
%S0002	Current sweep is the last sweep.
%S0003	0.01 second timer contact
%S0004	0.1 second timer contact
%S0005	1.0 second timer contact
%S0006	1.0 minute timer contact
%S0007	AlwaysON
%S0008	AlwaysOFF
%S0009	System table is full
%S0010	I/O fault table is full
%S0011	Override exists in %I,%Q,%M,%G Memory
%S0012	Reserved
%S0013	Background program check active
%S0014	Reserved
%S0015	Reserved
%S0016	Reserved
%S0017	Reserved
%S0018	Reserved
%S0019	Reserved
%S0020	Reserved
%S0021	Reserved
%S0022	Reserved
%S0023	Reserved
%S0024	Reserved
%S0025	Reserved
%S0026	Reserved
%S0027	Reserved
%S0028	Reserved
%S0029	Reserved
%S0030	Reserved
%S0031	Reserved
%S0032	Reserved

Special Contact References	
Reference Address	Reference Description
%SA001	Program checksum failure
%SA002	Exceeded constant sweep time
%SA003	Application fault occurred
%SA004	Reserved
%SA005	Reserved
%SA006	Reserved
%SA007	Reserved
%SA008	Reserved
%SA009	System configuration mismatch
%SA010	PLC CPU hardware failure
%SA011	Battery voltage is low
%SA012	Reserved
%SA013	Loss of IOC
%SA014	Loss of I/O module
%SA015	Loss of special I/O module
%SA016	Reserved
%SA017	Reserved
%SA018	Addition of I/O controller
%SA019	Addition of I/O module
%SA020	Addition of special I/O module
%SA021	Reserved
%SA022	I/O controller fault
%SA023	I/O module fault
%SA024	Reserved
%SA025	Reserved
%SA026	Reserved
%SA027	Hardware failure in special module
%SA028	Reserved
%SA029	Software fault in IOC
%SA030	Reserved
%SA031	Software fault in special module
%SA032	Reserved

B

Special Contact References	
Reference Address	ReferenceDescription
%SB001	Reserved
%SB002	Reserved
%SB003	Reserved
%SB004	Reserved
%SB005	Reserved
%SB006	Reserved
%SB007	Reserved
%SB009	No user program
%SB010	Corrupted user RAM
%SB011	Password access failure
%SB012	Null system configuration
%SB013	PLC CPU software failure
%SB014	PLC store failure
%SB015	Reserved
%SB016	Reserved
%SB017	Reserved
%SB018	Reserved
%SB019	Reserved
%SB020	Reserved
%SB021	Reserved
%SB022	Reserved
%SB023	Reserved
%SB024	Reserved
%SB025	Reserved
%SB026	Reserved
%SB027	Reserved
%SB028	Reserved
%SB029	Reserved
%SB030	Reserved
%SB031	Reserved
%SB032	Reserved

Special Contact References	
Reference Address	ReferenceDescription
%SC001	Reserved
%SC002	Reserved
%SC003	Reserved
%SC004	Reserved
%SC005	Reserved
%SC006	Reserved
%SC008	Reserved
%SC009	Some fault has occurred
%SC010	System fault has occurred
%SC011	I/O fault has occurred
%SC012	System fault table entry present
%SC013	I/O fault table entry present
%SC014	Hardware fault occurred
%SC015	Software fault occurred
%SC016	Reserved
%SC017	Reserved
%SC018	Reserved
%SC019	Reserved
%SC020	Reserved
%SC021	Reserved
%SC022	Reserved
%SC023	Reserved
%SC024	Reserved
%SC025	Reserved
%SC026	Reserved
%SC027	Reserved
%SC028	Reserved
%SC029	Reserved
%SC030	Reserved
%SC031	Reserved
%SC032	Reserved

Note

These references may be viewed in data mode by repeatedly pressing the SR key to toggle through the selections.

Table B-1. Special System Registers

Reference	Display Format	Description
%SR001	Hexadecimal	Type of PLC.
%SR002	Hexadecimal	Revision code of the PLC's firmware.
%SR003 - %SR006	Hexadecimal	Encoded form of level 2 password.
%SR007 - %SR010	Hexadecimal	Encoded form of level 3 password.
%SR011 - %SR014	Hexadecimal	Encoded form of level 4 password.
%SR015	Signed decimal	User program memory still available.
%SR016	Signed decimal	Current scan time of the PLC in milliseconds.

Appendix C

List of Functions

The following table lists the functions available for the Series 90-30 Hand-Held Programmer. A brief description of each function is included.

Table C-1. List of Functions

Function Number	Function Mnemonic	Description
00	ENDSW	Terminate program logic execution.
01	NOOP	Perform no operation.
03	JUMP	Nested Jump. Jump to prior / next LABEL function.
04	MCR	Nested MCR. Exert master control relay to next END MCR function.
07	LABEL	Provides destination for JUMP with matching label number.
08	ENDMCR	Terminate MCR function range.
10	TMR	Simple on-delay timing.
13	ONDTR	Stopwatch on-delay timing.
14	OFDTR	Off-delay timer.
15	UPCTR	Up counter.
16	DNCTR	Down counter.
22	BITSET	Sets a particular bit in a string of bits to 1.
23	AND	Logically <i>and</i> one 16-bit word to another.
24	BITCLR	Sets a particular bit in a string of bits to 0.
25	OR	Logically <i>or</i> one 16-bit word to another.
26	BITTST	Determines if a particular bit in a string of bits is set to a 1 or 0.
27	XOR	Logically <i>exclusive or</i> one 16-bit word to another.
28	BITPOS	Determines which bit in a string of bits is set to a 1.
29	NOT	Logically <i>negate</i> one 16-bit word to its complement.
30	SHL	Logically shift left a word array by <i>N</i> bits.
31	SHR	Logically shift right a word array by <i>N</i> bits.
32	ROL	Logically rotate left a word array by <i>N</i> bits.
33	ROR	Logically rotate right a word array by <i>N</i> bits.
37	MOVIN	Move an array of 16-bit words from one location to another.
38	BMOVI	Move seven 16-bit constants to a destination.

Table C-1. List of Functions - continued

Function Number	Function Mnemonic	Description
40	MOVBN	Move one or more bits from one reference to another reference.
42	MOVWN	Move an array of 16-bit words from one location to another.
43	BMOVW	Move seven 16-bit constants to a destination.
44	BLKCL	Zero-fill an array of 16-bit words.
45	SHFRW	N stage shift register of 16-bit words.
46	SHFRB	Implements a shift register to shift a bit.
47	SEQB	N state bit sequencer.
52	EQ	Test for one signed integer equal to another.
53	NE	Test for one signed integer not equal to another.
54	LE	test for one signed integer less than or equal to another.
55	GE	Test for one signed integer greater than or equal to another.
56	LT	Test for one signed integer less than another.
57	GT	Test for one signed integer greater than another.
60	ADD	Add one signed integer to another.
61	DPADD	Add one signed double precision integer to another.
62	SUB	Subtract one signed integer from another.
63	DPSUB	Subtract one signed double precision integer from another.
64	MUL	Multiply two signed integers together.
65	DPMUL	Multiply two signed double precision integers together.
66	DIV	Divide one signed integer by another.
67	DPDIV	Divide one signed double precision integer by another.
68	MOD	Modulo divide one signed integer by another.
69	DPMOD	Modulo divide one signed double precision integer by another.
70	SQRT	Find the square root of one signed integer.
71	DPSQRT	Find the square root of one double precision integer.
72	DPEQ	Test for one signed double precision integer equal to another.
73	DPNE	Test for one signed double precision integer not equal to another.
74	DPLE	Test for one signed double precision integer less than or equal to another.
75	DPGE	Test for one signed double precision integer greater than or equal to another.
76	DPLT	Test for one signed double precision integer less than another.
77	DPGT	Test for one signed double precision integer greater than another.
80	BCD	Convert a signed integer value to BCD.
81	INT	Convert a BCD value to signed integer.
85	DOI/O	Perform immediate I/O snapshot.
86	PIDISA	Implements an ISA standard PID ISA algorithm.
87	PIDIND	Implements an ISA standard PID IND algorithm.

Table C-1. List of Functions - continued

Function Number	Function Mnemonic	Description
88	COMRQ	Communicationsrequest.
89	SVCRRQ	System service request.
90	CALLSUB	Call a subroutine
101	SREQB	Search for all array values equal to a specified byte value.
102	SREQW	Search for all array values equal to a specified word value.
103	SREQI	Search for all array values equal to a specified integer value.
104	SREQDI	Search for all array values equal to a specified double precision integer value.
105	SRNEB	Search for all array values not equal to a specified byte value.
106	SRNEW	Search for all array values not equal to a specified word value.
107	SRNEI	Search for all array values not equal to a specified integer value.
108	SRNEDI	Search for all array values not equal to a specified double precision integer value.
109	SRLTB	Search for all array values less than a specified byte value.
110	SRLTW	Search for all array values less than a specified word value.
111	SRLTI	Search for all array values less than a specified integer value.
112	SRLTDI	Search for all array values less than a specified double precision integer value.
113	SRLEB	Search for all array values less than or equal to a specified byte value.
114	SRLEW	Search for all array values less than or equal to a specified word value.
115	SRLEI	Search for all array values less than or equal to a specified integer value.
116	SRLEDI	Search for all array values less than or equal to a specified double precision integer value.
117	SRGTB	Search for all array values greater than a specified byte value.
118	SRGTW	Search for all array values greater than a specified word value.
119	SRGTI	Search for all array values greater than a specified integer value.
120	SRGTDI	Search for all array values greater than a specified double precision integer value.
121	SRGEB	Search for all array values greater than or equal to a specified byte value.
122	SRGEW	Search for all array values greater than or equal to a specified word value.
123	SRGEI	Search for all array values greater than or equal to a specified integer value.
124	SRGEDI	Search for all array values greater than or equal to a specified double precision integer value.
130	MOVABI	Copy a specified number of elements from a bit source array to a bit destination array.
131	MOVABY	Copy a specified number of elements from a byte source array to a byte destination array.
132	MOVAW	Copy a specified number of elements from a word source array to a word destination array.
133	MOVAI	Copy a specified number of elements from an integer source array to an integer destination array.

Table C-1. List of Functions - continued

Function Number	Function Mnemonic	Description
134	MOVADI	Copy a specified number of elements from a double precision integer source array to a double precision integer destination array.
140	RANGI	Determine if a value is within the range of two signed integer values.
141	RANGDI	Determine if a value is within the range of two double precision signed integer values.
142	RANGW	Determine if a value is within the range of two word values.
143	MSKMPW	Compare contents of two bit strings (16-bit words) with the ability to mask selected bits.
144	MSKMPD	Compare contents of two bit strings (32-bit words) with the ability to mask selected bits.

Appendix D

Function Parameters

The following table lists the parameters for each function and their default display format.

Table D-1. Function Parameters

Function	Parameter	Logicmaster Abbreviation	Default Display Format
On-Delay Timer: TMR (Function 10)	P1: Timer Accuracy P2: Preset Time P3: TimerLocation		signed decimal signeddecimal signeddecimal
On-Delay Timer: ONDTR (Function 13)	P1: Timer Accuracy P2: Preset Time P3: TimerLocation		signed decimal signeddecimal signeddecimal
Off-Delay Timer: OFDTR (Function 14)	P1: Timer Accuracy P2: Preset Time P3: TimerLocation		signed decimal signeddecimal signeddecimal
Up Counter: UPCTR (Function 15)	P1: Preset Value P2: Counter Location		signed decimal signeddecimal
Down Counter: DNCTR (Function 16)	P1: Preset Value P2: Counter Location		signed decimal signeddecimal
Bit Set: BITSET (Function 22)	P1: Begin string P2: Bit to Set P3: String Length	IN BIT LEN	signed decimal signeddecimal signeddecimal
Logical AND: AND (Function 23)	P1: Input P2: Input P3: Output	I1 I2 Q	signed decimal signeddecimal signeddecimal
Bit Clear: BITCLR (Function 24)	P1: Begin String P2: Bit to Set P3: String Length	IN BIT LEN	signed decimal signeddecimal signeddecimal
Logical OR: OR (Function 25)	P1: Input P2: Input P3: Output	I1 I2 Q	signed decimal signeddecimal signeddecimal
Bit Test: BITTST (Function 26)	P1: Begin String P2: Bit to Test P3: String Length	IN BIT LEN	signed decimal signeddecimal signeddecimal
Logical XOR: XOR (Function 27)	P1: Input P2: Input P3: Output	I1 I2 Q	signed decimal signeddecimal signeddecimal
Bit Position: BITPOS (Function 28)	P1: Begin String P2: String Length P3: Destination	IN LEN POS	signed decimal signeddecimal signeddecimal

Table D-1. Function Parameters - continued

Function	Parameter	Logicmaster Abbreviation	Default Display Format
LogicalNOT: NOT (Function29)	P1: Input P2: Output	I1 Q	signed decimal signeddecimal
Bit Shift Left: SHL (Function30)	P1: Input Array P2: Shift Distance P3: Length P4: Output Array	IN N LEN Q	signed decimal signeddecimal signeddecimal signeddecimal
Bit Shift Right: SHR (Function31)	P1: Input Array P2: Shift Distance P3: Length P4: Output Array	IN N LEN Q	signeddecimal signeddecimal signed decimal signeddecimal
Bit Rotate Left: ROL (Function32)	P1: Input Array P2: Shift Distance P3: Length P4: Output Array	IN N LEN Q	signeddecimal signeddecimal signeddecimal signeddecimal
Bit Rotate Right: ROR (Function33)	P1: Input Array P2: Shift Distance P3: Length P4: Output Array	IN N LEN Q	signeddecimal signeddecimal signeddecimal signeddecimal
Multiple Word Move: MOVIN (Function37)	P1: Input P2: Length P3: Output	IN LEN Q	signed decimal signeddecimal signeddecimal
Constant Block Move: BMOVI (Function38)	P1: Constant P2: Constant P3: Constant P4: Constant P5: Constant P6: Constant P7: Constant P8: Output	IN1 IN2 IN3 IN4 IN5 IN6 IN7 Q	signed decimal signeddecimal signeddecimal signeddecimal signeddecimal signeddecimal signeddecimal signeddecimal
Move Bits: MOVBN (Function40)	P1: Begin String P2: String Length P3: Destination	IN LEN Q	signed decimal signeddecimal signeddecimal
Multiple Word Move: MOVWN (Function42)	P1: Input P2: Length P3: Output	IN LEN Q	signed decimal signeddecimal signeddecimal
Constant Block Move: BMOVW (Function43)	P1: Constant P2: Constant P3: Constant P4: Constant P5: Constant P6: Constant P7: Constant P8: Output	IN1 IN2 IN3 IN4 IN5 IN6 IN7 Q	signed decimal signeddecimal signeddecimal signeddecimal signeddecimal signeddecimal signeddecimal signeddecimal
Block Clear: BLKCL (Function44)	P1: Start Reference P2: Length	IN LEN	signed decimal signeddecimal
Shift Register: SHFRW (Function45)	P1: Input P2: Location P3: Length P4: Output	IN ST LEN Q	signed decimal signeddecimal signeddecimal signeddecimal

Table D-1. Function Parameters - continued

Function	Parameter	Logicmaster Abbreviation	Default Display Format
Shift Register Bit: SHFRB (Function 46)	P1: Bit to Shift P2: Start Address P3: Register Length P4: Bit Destination	IN ST LEN Q	signed decimal signeddecimal signeddecimal signeddecimal
Bit Sequencer: SEQB (Function 47)	P1: Length P2: Start Address P3: Sequencer Location P4: Sequencer Location	STEP STRT LEN LEN	signed decimal signeddecimal signeddecimal signeddecimal
Equal: EQ (Function 52)	P1: Input P2: Input	I1 I2	signeddecimal signeddecimal
Not Equal: NE (Function 53)	P1: Input P2: Input	I1 I2	signeddecimal signeddecimal
Less Than or Equal: LE (Function 54)	P1: Input P2: Input	I1 I2	signed decimal signeddecimal
Greater Than or Equal: GE (Function 55)	P1: Input P2: Input	I1 I2	signed decimal signeddecimal
Less Than: LT (Function 56)	P1: Input P2: Input	I1 I2	signed decimal signeddecimal
Greater Than: GT (Function 57)	P1: Input P2: Input	I1 I2	signeddecimal signeddecimal
Addition: ADD (Function 60)	P1: Input P2: Input P3: Output	I1 I2 Q	signed decimal signeddecimal signeddecimal
Double Precision Addition: DPADD (Function 61)	P1: Input P2: Input P3: Output	I1 I2 Q	signed decimal signeddecimal signeddecimal
Subtraction: SUB (Function 62)	P1: Input P2: Input P3: Output	I1 I2 Q	signed decimal signeddecimal signeddecimal
Double Precision Subtraction: DPSUB (Function 63)	P1: Input P2: Input P3: Output	I1 I2 Q	signed decimal signeddecimal signeddecimal
Multiplication: MUL (Function 64)	P1: Input P2: Input P3: Output	I1 I2 Q	signeddecimal signeddecimal signeddecimal
Double Precision Multiplication: DPMUL (Function 65)	P1: Input P2: Input P3: Output	I1 I2 Q	signeddecimal signed decimal signeddecimal
Division: DIV (Function 66)	P1: Input P2: Input P3: Output	I1 I2 Q	signed decimal signeddecimal signeddecimal
Double Precision Division: DPDIV (Function 67)	P1: Input P2: Input P3: Output	I1 I2 Q	signed decimal signeddecimal signeddecimal

Table D-1. Function Parameters - continued

Function	Parameter	Logicmaster Abbreviation	Default Display Format
Modulo: MOD (Function 68)	P1: Input P2: Input P3: Output	I1 I2 Q	signeddecimal signeddecimal signeddecimal
Double Precision Modulo: DPMOD (Function 69)	P1: Input P2: Input P3: Output	I1 I2 Q	signed decimal signeddecimal signeddecimal
Square Root: SQRT (Function 70)	P1: Input Value P2: Output Value	IN Q	signed decimal signeddecimal
Double Precision Square Root: DPSQRT (Function 71)	P1: Input Value P2: Output Value	IN Q	signed decimal signeddecimal
Double Precision Equal: DPEQ (Function 72)	P1: Input P2: Input	I1 I2	signed decimal signeddecimal
Double Precision Not Equal: DPNE (Function 73)	P1: Input P2: Input	I1 I2	signeddecimal signeddecimal
DP Less Than or Equal: DPLE (Function 74)	P1: Input P2: Input	I1 I2	signeddecimal signeddecimal
DP Greater Than or Equal: DPGE (Function 75)	P1: Input P2: Input	I1 I2	signed decimal signeddecimal
Double Precision Less Than: DPLT (Function 76)	P1: Input P2: Input	I1 I2	signed decimal signeddecimal
Double Precision Greater Than: DPGT (Function 77)	P1: Input P2: Input	I1 I2	signed decimal signeddecimal
INT to BCD Conversion: BCD (Function 80)	P1: Input P2: Output	I1 Q	signed decimal signeddecimal
BCD to INT Conversion: INT (Function 81)	P1: Input P2: Output	I1 Q	signed decimal signeddecimal
DoI/O: DOI/O (Function 85)	P1: Start P2: End P3: Destination	ST END ALT	signed decimal signeddecimal signeddecimal
PIDISA: PIDISA (Function 86)	P1: Desired Set Point P2: Process Variable P3: Data Structure Location P4: Control Variable	SP PV LOC CV	signed decimal signeddecimal signeddecimal signeddecimal
PID IND: PIDIND (Function 87)	P1: Desired Set Point P2: Process Variable P3: Data Structure Location P4: Control Variable	SP PV LOC CV	signed decimal signeddecimal signeddecimal signeddecimal
Communications Request: COMRQ (Function 88)	P1: Command P2: SYSID P3: TASK	CMD SYSID TASK	signed decimal signeddecimal signeddecimal
Service Request: SVCRQ (Function 89)	P1: Request Number P2: Output	FNC PARAM	signed decimal signeddecimal

Table D-1. Function Parameters - continued

Function	Parameter	Logicmaster Abbreviation	Default Display Format
Subroutine Call: CALLSUB (Function 90)	P1: Subroutine Number	none	signeddecimal
Search Equal To (Byte): SREQB (Function 101)	P1: Array Start Address P2: Index Into Array P3: Object of Search P4: Length P5: TargetLocation	AR NXIN IN LEN NXOUT	signeddecimal signeddecimal signeddecimal signeddecimal signeddecimal
Search Equal To (Word): SREQW (Function 102)	P1: Array Start Address P2: Index Into Array P3: Object of Search P4: Length P5: TargetLocation	AR NXIN IN LEN NXOUT	signed decimal signeddecimal signeddecimal signeddecimal signeddecimal
Search Equal To (INT): SREQI (Function 103)	P1: Array Start Address P2: Index Into Array P3: Object of Search P4: Length P5: TargetLocation	AR NXIN IN LEN NXOUT	signed decimal signeddecimal signeddecimal signeddecimal signeddecimal
Search Equal To (DINT): SREQDI (Function 104)	P1: Array Start Address P2: Index Into Array P3: Object of Search P4: Length P5: TargetLocation	AR NXIN IN LEN NXOUT	signeddecimal signed decimal signeddecimal signeddecimal signeddecimal
Search Not Equal To (Byte): SRNEB (Function 105)	P1: Array Start Address P2: Index Into Array P3: Object of Search P4: Length P5: TargetLocation	AR NXIN IN LEN NXOUT	signed decimal signeddecimal signeddecimal signeddecimal signeddecimal
Search Not Equal To (Word): SRNEW (Function 106)	P1: Array Start Address P2: Index Into Array P3: Object of Search P4: Length P5: TargetLocation	AR NXIN IN LEN NXOUT	signed decimal signeddecimal signeddecimal signeddecimal signeddecimal
Search Not Equal To (INT): SRNEI (Function 107)	P1: Array Start Address P2: Index Into Array P3: Object of Search P4: Length P5: TargetLocation	AR NXIN IN LEN NXOUT	signed decimal signeddecimal signeddecimal signeddecimal signeddecimal
Search Not Equal To (DINT): SRNEDI (Function 108)	P1: Array Start Address P2: Index Into Array P3: Object of Search P4: Length P5: TargetLocation	AR NXIN IN LEN NXOUT	signed decimal signeddecimal signeddecimal signeddecimal signeddecimal
Search Less Than (Byte): SRLTB (Function 109)	P1: Array Start Address P2: Index Into Array P3: Object of Search P4: Length P5: TargetLocation	AR NXIN IN LEN NXOUT	signed decimal signeddecimal signeddecimal signeddecimal signeddecimal

Table D-1. Function Parameters - continued

Function	Parameter	Logicmaster Abbreviation	Default Display Format
Search Less Than (Word): SRLTW (Function 110)	P1: Array Start Address P2: Index Into Array P3: Object of Search P4: Length P5: TargetLocation	AR NXIN IN LEN NXOUT	signed decimal signeddecimal signeddecimal signeddecimal signeddecimal
Search Less Than (INT): SRLTI (Function 111)	P1: Array Start Address P2: Index Into Array P3: Object of Search P4: Length P5: TargetLocation	AR NXIN IN LEN NXOUT	signed decimal signeddecimal signeddecimal signeddecimal signeddecimal
Search Less Than (DINT): SRLTDI (Function 112)	P1: Array Start Address P2: Index Into Array P3: Object of Search P4: Length P5: TargetLocation	AR NXIN IN LEN NXOUT	signed decimal signeddecimal signeddecimal signeddecimal signeddecimal
Search Less Than or Equal To (Byte): SRLEB (Function 113)	P1: Array Start Address P2: Index Into Array P3: Object of Search P4: Length P5: TargetLocation	AR NXIN IN LEN NXOUT	signed decimal signeddecimal signeddecimal signeddecimal signeddecimal
Search Less Than or Equal To (Word): SRLEW (Function 114)	P1: Array Start Address P2: Index Into Array P3: Object of Search P4: Length P5: TargetLocation	AR NXIN IN LEN NXOUT	signeddecimal signed decimal signeddecimal signeddecimal signeddecimal
Search Less Than or Equal To (INT): SRLEI (Function 115)	P1: Array Start Address P2: Index Into Array P3: Object of Search P4: Length P5: TargetLocation	AR NXIN IN LEN NXOUT	signed decimal signeddecimal signeddecimal signeddecimal signeddecimal
Search Less Than or Equal To (DINT): SRLEDI (Function 116)	P1: Array Start Address P2: Index Into Array P3: Object of Search P4: Length P5: TargetLocation	AR NXIN IN LEN NXOUT	signed decimal signeddecimal signeddecimal signeddecimal signeddecimal
Search Greater Than (Byte): SRGTB (Function 117)	P1: Array Start Address P2: Index Into Array P3: Object of Search P4: Length P5: TargetLocation	AR NXIN IN LEN NXOUT	signed decimal signeddecimal signeddecimal signeddecimal signeddecimal
Search Greater Than (Word): SRGTW (Function 118)	P1: Array Start Address P2: Index Into Array P3: Object of Search P4: Length P5: TargetLocation	AR NXIN IN LEN NXOUT	signed decimal signeddecimal signeddecimal signeddecimal signeddecimal
Search Greater Than (INT): SRGTI (Function 119)	P1: Array Start Address P2: Index Into Array P3: Object of Search P4: Length P5: TargetLocation	AR NXIN IN LEN NXOUT	signed decimal signeddecimal signeddecimal signeddecimal signeddecimal

Table D-1. Function Parameters - continued

Function	Parameter	Logicmaster Abbreviation	Default Display Format
Search Greater Than (DINT): SRGTDI (Function 120)	P1: Array Start Address P2: Index Into Array P3: Object of Search P4: Length P5: TargetLocation	AR NXIN IN LEN NX OUT	signed decimal signeddecimal signeddecimal signeddecimal signeddecimal
Search Greater Than or Equal To (Byte): SRGEB (Function 121)	P1: Array Start Address P2: Index Into Array P3: Object of Search P4: Length P5: TargetLocation	AR NXIN IN LEN NX OUT	signed decimal signeddecimal signeddecimal signeddecimal signeddecimal
Search Greater Than or Equal To (Word): SRGEW (Function 122)	P1: Array Start Address P2: Index Into Array P3: Object of Search P4: Length P5: TargetLocation	AR NXIN IN LEN NX OUT	signed decimal signeddecimal signeddecimal signeddecimal signeddecimal
Search Greater Than or Equal To (INT): SRGEI (Function 123)	P1: Array Start Address P2: Index Into Array P3: Object of Search P4: Length P5: TargetLocation	AR NXIN IN LEN NX OUT	signed decimal signeddecimal signeddecimal signeddecimal signeddecimal
Search Greater Than or Equal To (DINT): SRGEDI (Function 124)	P1: Array Start Address P2: Index Into Array P3: Object of Search P4: Length P5: TargetLocation	AR NXIN IN LEN NX OUT	signed decimal signed decimal signeddecimal signeddecimal signeddecimal
Array Move (Bit): MOVABI (Function 130)	P1: Source Start P2: Index Into Source P3: Index into Destination P4: # Elements to Move P5: # Elements in Array P6: Destination Start	SR SNX DNX N LEN DS	signeddecimal signeddecimal signeddecimal signeddecimal signeddecimal signeddecimal
Array Move (Byte): MOVABY (Function 131)	P1: Source Start P2: Index Into Source P3: Index into Destination P4: # Elements to Move P5: # Elements in Array P6: Destination Start	SR SNX DNX N LEN DS	signed decimal signeddecimal signeddecimal signeddecimal signeddecimal signeddecimal
Array Move (Word): MOVAW (Function 132)	P1: Source Start P2: Index Into Source P3: Index into Destination P4: # Elements to Move P5: # Elements in Array P6: Destination Start	SR SNX DNX N LEN DS	signeddecimal signeddecimal signeddecimal signeddecimal signeddecimal signeddecimal
Array Move (INT): MOVAI (Function 133)	P1: Source Start P2: Index Into Source P3: Index into Destination P4: # Elements to Move P5: # Elements in Array P6: Destination Start	SR SNX DNX N LEN DS	signed decimal signeddecimal signeddecimal signeddecimal signeddecimal signeddecimal

Table D-1. Function Parameters - continued

Function	Parameter	Logicmaster Abbreviation	Default Display Format
Array Move (DINT): MOVADI (Function 134)	P1: Source Start P2: Index Into Source P3: Index into Destination P4: # Elements to Move P5: # Elements in Array P6: Destination Start	SR SNX DNX N LEN DS	signed decimal signeddecimal signeddecimal signeddecimal signeddecimal signeddecimal
Range (INT) RANGI (Function 140)	P1: Lower limit value P2: Upper limit value P3: Value to be compared	L1 L2 IN	signeddecimal signeddecimal signeddecimal
Range (DINT) RANGDI (Function 141)	P1: Lower limit value P2: Upper limit value P3: Value to be compared	L1 L2 IN	signeddecimal signeddecimal signeddecimal
Range (WORD) RANGW (Function 142)	P1: Lower limit value P2: Upper limit value P3: Value to be compared	L1 L2 IN	signeddecimal signeddecimal signeddecimal
Masked Compare (Word): MSKMPW (Function 143)	P1: First bit string P2: Second bit string P3: Bit string mask P4: Start of next compare P5: # words in string P6: Copy of M bit string P7: # of last compare bit	I1 I2 M BIT LEN Q BN	signed decimal signeddecimal signeddecimal signeddecimal signeddecimal signeddecimal signeddecimal
Masked Compare (DWord): MSKMPD (Function 144)	P1: First bit string P2: Second bit string P3: Bit string mask P4: Start of next compare P5: # words in string P6: Copy of M bit string P7: # of last compare bit	I1 I2 M BIT LEN Q BN	signed decimal signeddecimal signeddecimal signeddecimal signeddecimal signeddecimal signeddecimal

A

Abbreviations, hand-held programmer,
Micro plc
common, 4-7
counter Type A, 4-7, 4-8
counter Type B, 4-10

Access levels, protection mode, 8-5

Active constant sweep mode parameter,
3-6

Active constant sweep setting parameter,
3-7

Analog I/O modules, configuration, 5-27
16-channel current input, 5-32
16-channel voltage input, 5-27
8-channel voltage/current input, 5-37
current/voltage input/output combo,
5-42

Appendix
A - glossary of terms, A-1
B - special contact references, B-1
C - list of functions, C-1
D - function parameters, D-1

Arithmetic Functions, 9-61
addition (func 60), 9-62
description of, 9-61
division (func 66), 9-77
double precision addition (func 61),
9-62
double precision division (func 67), 9-77
double precision modulo division (func
69), 9-82
double precision multiplication (func
65), 9-72
double precision subtraction (func 63),
9-67
modulo division (func 68), 9-82
multiplication (func 64), 9-72
square root, double precision integer,
(func 71), 9-87
square root, integer, (func 70), 9-87
subtraction (func 62), 9-67

Array move functions, 9-290

Automatic I/O configuration, 5-7

B

Basic instructions and reference types,
A-11

Baud rate parameter, 3-9

Bit clear (BITCLR) function 24, 9-165

Bit Operation Functions

bit clear, BITCLR (func 24), 9-165
bit position, BITPOS (func 28), 9-172
bit rotate left, ROL (func 32), 9-149
bit rotate right, ROR (func 33), 9-155
bit set, BITSET (func 22), 9-161
bit shift left, SHL (func 30), 9-137
bit shift right, SHR (func 31), 9-143
bit test, BITTST (func 26), 9-169
bitwise AND (func 23), 9-122
bitwise exclusive or, XOR (func 27),
9-130
bitwise NOT (func 29), 9-134
bitwise OR (func 25), 9-126
description of, 9-121

Bit position (BITPOS) function 28, 9-172

Bit rotate left (ROL) function 32, 9-149

Bit rotate right (ROR) function 33, 9-155

Bit set (BITSET) function 22, 9-161

Bit shift left (SHL) function 30, 9-137

Bit shift right (SHR) function 31, 9-143

Bit test (BITTST) function 26, 9-169

Bitwise and (AND) function 23, 9-122

Bitwise exclusive or (XOR) function 27,
9-130

Bitwise not (NOT) function 29, 9-134

Bitwise or (OR) function 25, 9-126

Block clear (BLKCL) function 44, 9-198

Block move BMOVE (BMOVI and
BMOVW) function 38 and 43, 9-192

C

Cable for HHP, 2-1

Cancel configuration operation, 3-13

Cancel OEM key change, 8-11

Canceling a configuration operation, 5-13

Canceling a data value change operation,
7-8

Canceling a mode change, 2-11

Catalog numbers, EEPROM/EPROM,
2-12

Clearing all overrides, 7-11

Clearing memory, 2-7

Communications, 1-2

- Communications module, enhanced genius, 5-18
- Communications module, genius, 5-18
- Communications request (COMMREQ) function 88, 9-220
- Configuration
 - analog I/O modules, 5-27
 - 16-channel current input, 5-32
 - 16-channel voltage input, 5-27
 - 8-channel voltage/current input, 5-37
 - current/voltage input/output combo, 5-42
 - cancel current operation, 5-13
 - continuous counting, 4-17
 - count output enable, 4-16
 - counter direction, 4-17
 - counter edge, 4-16 , 4-17
 - counter enable, 4-16
 - counter mode, 4-17
 - counter strobe/preload selection, 4-17
 - deleting, 5-12
 - discrete module, 5-10
 - generic module, 5-20
 - genius communications module, 5-18
 - high limit, 4-18
 - high speed counter
 - Micro plc, 4-7
 - Series 90-30, 5-21
 - I/Q 5-1
 - I/O link interface module, 5-15
 - low limit, 4-18
 - Micro plc high speed counter, 4-7
 - Micro plc hsc configuration
 - count limits, 4-12
 - counter direction, 4-11
 - counter mode, 4-11
 - counter timebase, 4-12
 - counter type, 4-11
 - location of preset points, 4-14
 - output failure mode, 4-11
 - output preset positions, 4-13
 - preload value, 4-14
 - strobe sdge, 4-12
 - off preset value, 4-18
 - on preset value, 4-18
 - one-shot counting, 4-17
 - PLC, 3-1
 - preload value, 4-18
 - programmable coprocessor module, 5-22
 - pulse output, 4-19
 - PWM output, 4-19
 - reading a, 5-11 , 5-17 , 5-18
 - remote I/O rack, 5-5
 - replacing a, 5-12
 - saved, 5-7
 - strobe edge, 4-16 , 4-17
 - time base value, 4-17
- Configuration features, continuous counting, 4-11
- Configuration Mode
 - cancel, 3-13
 - enter, 3-2
 - exit, 3-13
 - go to operation, 3-4
 - I/O configuration, 5-1
 - keypad summary, 3-3
 - locate slot/rack, 3-4
 - screen display, 3-4
- Configuration screens
 - analog modules
 - 16-channel current input, 5-32
 - 16-channel voltage input, 5-27
 - 8-channel current/voltage input, 5-37
 - current/voltage combination input/output, 5-42
 - discrete module, 5-10
 - Genius communications module, 5-18
 - I/O link interface module, 5-15
 - Micro plc
 - common, all counter types, 4-15
 - type A counter, 4-16
 - type B counter, 4-20
 - programmable coprocessor module, 5-22
- Configuration, automatic, 5-7
- Configuration/program portability, 2-17
- Configured constant sweep mode parameter, 3-7
- configured constant sweep setting parameter, 3-7
- Connection to Series 90 Micro plc, 2-1
- Connection to Series 90-20, 2-1
- Connection to Series 90-30, 2-1
- Contact references, special, B-1
- Control Functions
 - description of, 9-254
 - DO I/O enhanced (model 331, 340, 341, 351), 9-240
 - DO I/O snapshot (func 85), 9-234
 - END MCR (func 8), 9-246
 - LABEL (func 7), 9-250

- nested jump, JUMP (func 3), 9-242
- nested master control relay, MCR (func 3), 9-246
- no operation, NOOP (func 1), 9-241
- pid, 9-254
- PID IND (func 87), 9-254
- PID ISA (func 86), 9-254
- subroutine CALLSUB (func 90), 9-266
- system service request, SVCRQ (func 89), 9-251
- terminate program execution, ENDSW (func 0), 9-241
- Conversion Functions
 - BCD To integer conversion, INT (func 81), 9-229
 - integer to BCD conversion, BCD (func 80), 9-225
- CPU 351 operating note, 9-1
- CPU ID parameters, 3-10

- D**
- Data bits parameter, 3-9
- Data Mode
 - entering, 7-1
 - exit, 7-12
 - keypad summary, 7-2
 - plc control and status, 8-1
 - screen display, 7-3
- Data Move Functions, 9-183
 - block clear, BLKCL (func 44), 9-198
 - block move, hex, BMOVW (func 43), 9-192
 - block move, integer, BMOVI (func 38), 9-192
 - communications request, COMMREQ (func 88), 9-220
 - move bits, MOVBN (func 40), 9-188
 - move word, hex, MOVWN (func 42), 9-184
 - move word, integer, MOVIN (func 37), 9-184
 - shift register, bit, SHFRB (func 46), 9-208
 - shift register, word, SHFR (func 45), 9-201
 - stage bit sequencer, SEQB (func 47), 9-212
- Data retentiveness, 1-5
- Data table, clearing, 7-9
- Data types
 - BCD-4, 9-30
 - BIT, 9-30
 - BYTE, 9-30
 - DINT, 9-30
 - INT, 9-30
 - WORD, 9-30
- Data value, canceling change, 7-8
- Default I/O parameter, 3-11
- Default system configuration, 90-30, 5-14
- Delete a configuration, 5-12
- Deleting a locked subroutine, 8-14
- Deleting subroutines, 9-9
- Discrete module, configuring, 5-10
- Discrete reference tables, 7-3
- Discrete references
 - description of, 1-4
 - discrete inputs, 1-4
 - discrete internal, 1-4
 - discrete outputs, 1-4
 - discrete temporary, 1-4
 - global data, 1-4
 - system status, 1-4
- Discrete tables, 7-3
- Display format for configuration, 3-4
- Display formats, 7-3
- Display, changing format of, 7-5
- Display, error messages, 7-5
- DOI/O function, 9-234
 - description of, 9-234
 - enhanced for model 331, 340, 341, and 351 CPUs, 9-240
- Double precision
 - addition (DPADD) function 61, 9-62
 - division (DPDIV) function 67, 9-77
 - equal (DPEQ) function 72, 9-91
 - greater than comparison (DPGT) function, 9-99
 - greater than or equal comparison (DPGE) function 75, 9-103
 - less than comparison (DPLT) function 76, 9-107
 - less than or equal to comparison (DPLE) function 74, 9-111
 - module division (DPMOD) function 69, 9-82
 - multiplication (DPMUL) function 65, 9-72

- not equal comparison (DPNE) function
73, 9-95
- signed integer, 9-30
- square root (DPSQRT) function 71, 9-87
- subtraction (DPSUB) function 63, 9-67

Down counter (DNCTR) function 16, 9-57

Dual use checking parameter, 3-8

E

- Edit-locked subroutine, 8-14
- EEPROM source at power-up, 2-21
- EEPROM/EPR0M catalog numbers, 2-12
- Enhanced DO I/O function for model 331,
340, 341, and 351 CPUs, 9-240
- Enhanced genius communications mod-
ule, 5-18
- Entering a logic element, 9-11
- Entering data mode, 7-1
- Entering programs, guidelines, 9-6
- Entering subroutines, 9-7
- Equal function, 9-90
- Error messages
 - display options, 7-5
 - EEPROM/MEM card operation, 2-16
 - non-system, 10-1
- Exit data mode, 7-12
- Exiting configuration mode, 3-13

F

- Flash memory, Micro plc, saving the user
program in, 4-6
- Formats, display, 7-3
- Function numbers, list of, C-1
- Function parameters, D-1
- Functions
 - arithmetic, 9-61
 - bit operation, 9-121
 - control, 9-233
 - control functions, 9-233
 - conversion, 9-224
 - data move, 9-183
 - relational, 9-90
 - table, 9-268

- timers and counters, 9-37

Functions for statement list programming,
9-31

functions, list of, C-1

G

- Generic module configuration, 5-20
- Genius communications module, 5-18
- Genius communications module, en-
hanced, 5-18
- Global data references, 1-4
- Glossary of terms, A-1
- Glossary, basic instructions and reference
Types, A-11
- Greater than comparison (GT) function
57, 9-99
- Greater than function, 9-90
- Greater than or equal comparison (GE),
function 55, 9-103
- Greater than or equal function, 9-90
- Guidelines for entering programs, 9-6

H

- Hand-Held Programmer
 - cable, 2-1
 - communications with PLC, 1-2
 - configuration screens, for Micro plc, 4-3
 - connection to Series 90 Micro plc, 2-1
 - connection to Series 90-20 PLC, 2-1
 - connection to Series 90-30 PLC, 2-1
 - disconnecting, 2-2
 - discrete references, 1-3
 - features of, 1-1
 - how to use, 1-7
 - illustration of, 1-8
 - illustration of keypad, 2-3
 - installation and setup, 2-1
 - keypad, 2-2
 - keypad, description of, 1-1
 - LCD screen, 1-2
 - memory card, 1-2
 - memory card insertion, 2-13
 - operating modes, 1-2
 - operation of HHP, 2-1
 - power-up sequence, 2-2
 - subroutine display, 8-12

- subroutine protection status, display of, 8-12
 - Hand-Held Programmer abbreviations
 - Type A counter, Micro PLC, 4-8
 - Type B counter, Micro plc, 4-10
 - HHP installation, 2-1
 - High speed counter configuration
 - Micro plc, 4-7
 - Series 90-30, 5-21
- ## I
- I/O Configuration
 - analog I/O modules
 - 16-channel current input, 5-32
 - 16-channel voltage input, 5-27
 - 8-channel current/voltage input, 5-37
 - current/voltage combination input/output, 5-42
 - auto configuration, 5-5
 - automatic configuration, 5-7
 - Genius communications module, 5-18
 - high-speed counter, Series 90-30, 5-21
 - I/O link interface module, 5-15
 - I/O slots, 5-5
 - intelligent I/O module, 5-17
 - intelligent I/O modules, 5-17
 - keypad functionality, 5-8
 - non-intelligent I/O module, 5-9
 - non-intelligent I/O modules, 5-9
 - programmable coprocessor module, 5-22
 - reading a saved configuration, 5-7
 - remote I/O rack, 5-5
 - selecting rack size, 5-3
 - selecting slots in rack, 5-4
 - slots for I/O modules, 5-5
 - system configuration, default, 90-30, 5-14
 - I/O link interface, configuration, 5-15
 - I/O scan in sweep mode parameter, 3-8
 - I/O slots, configuration of, 5-5
 - IC693CBL303, cable for HHP, 2-1
 - Input references, discrete, 1-4
 - Input register references, analog, 1-3
 - Installation, HHP, 2-1
 - INT, 9-30
 - Integer to BCD Conversion (BCD) Function 80, 9-225
 - Intelligent I/O modules, 5-17
 - Internal references, discrete, 1-4
- ## J
- Jumper, user PROM option, 2-11
- ## K
- Key change, OEM, cancel, 8-11
 - Key click parameter, 3-5
 - Key sequences, special, 2-8
 - Key, OEM, 8-9
 - Keypad functionality, 6-2
 - data mode, 7-2
 - in I/O configuration mode, 5-8
 - Keys
 - edit/display, 2-4
 - ladder logic, 2-5
 - numeric, 2-6
 - program transfer, 2-6
- ## L
- Less than comparison (LT) function 56, 9-107
 - Less than function, 9-90
 - Less than or equal function, 9-90
 - Less than or equal to comparison (LE) function 54, 9-111
 - Locate slot in rack, 5-10
 - Logic element, entering, 9-11
- ## M
- Manual configuration, 5-5
 - Masked compare
 - MSKCMPI, function 144, 9-176
 - MSKMPW, function 143, 9-176
 - Memory card, 2-13, 4-3
 - load RAM, 2-14
 - store RAM, 2-15

- verify RAM, 2-16
- Memory card, plc configuration, 3-1
- Memory types for basic elements, 9-6
- Memory, clearing, 2-7
- Messages, error, 7-5
- Micro plc
 - abbreviations for all Type A counter configuration, 4-8
 - common parameter definitions, 4-7
 - compatibility with Series 90-30, 4-7
 - configuration, 4-2
 - hsc configuration, 4-7
 - count direction, 4-11
 - count limits, 4-12
 - counter mode, 4-11
 - counter timebase, 4-12
 - counter type, 4-11
 - location of preset points, 4-14
 - output failure mode, 4-11
 - output preset positions, 4-13
 - preload value, 4-14
 - strobe edge, 4-12
 - parameters, list of, 4-2
 - storing user program, 4-6
- Mode change, canceling, 2-11
- Mode exit, data, 7-12
- Mode, data, 7-1
- Mode, program, 6-2
- Modem turnaround time parameter, 3-9
- Modes, operating, 1-2
- Module, genius communications, 5-18
- Modulo division (MOD) function 68, 9-82
- Move bits (MOVBN) function 40, 9-188
- Move functions, array, 9-289
- Multiple word move MOVEN (MOVIN and MOVWN) function 37 and 42, 9-184

N

- Non-discrete tables, 7-4
- Not equal comparison (NE) function 53, 9-95
- Not equal function, 9-90

O

- OEM key, 8-9
- OEM Protection, 8-1
 - cancel, 8-9
 - cancel key change, 8-11
 - display/modify, 8-9
 - levels of, 8-2
 - lock/release, 8-8
 - reading EEPROM or memory card, 8-11
 - remove, 8-11
- Off delay (OFDTR) function 14, 9-48
- On delay (ONDTR) function 13, 9-43
- On-line changes
 - boolean instruction, 6-8
 - reference address, 6-8
 - valid, 6-19
- On-line substitution groups, 6-19
- Operating modes, 1-2
 - config, 2-8
 - configuration mode, 1-2
 - data, 2-8
 - data mode, 1-2
 - program, 2-8
 - program edit, 6-1
 - program mode, 1-2
 - protect, 2-8
 - protection mode, 1-2
 - selection of, 2-8
- Option, user PROM, 2-11
- Output references, discrete, 1-4
- Output register references, analog, 1-3
- Overrides, 1-4
- Overrides, clearing all, 7-11
- Overriding, discrete reference, 7-9

P

- Parameter definitions
 - for Micro plc, 4-7
 - for Micro plc HSC configuration, 4-7
- Parameters for Micro plc, 4-2
- Parameters, function, D-1
- Parameters, rack, 3-4
- Parity parameter, 3-9
- Password parameter, 3-10

- Password protection, 8-1
- Password protection levels, 8-1
- Passwords
 - cancel change, 8-8
 - display / modify 8-7
 - OEM protection, 8-8
- PID data structure, 9-256
- PID function, ziegler and nichols tuning approach, 9-261
- PID function block data, 9-257
- PID functions, differences, 9-260
- PID IND, function 87, 9-254
- PID, initialization values, 9-259
- PIDIND block diagram, 9-260
- PIDISA block diagram, 9-260
- PLC Configuration
 - accessing parameters for configuration, 3-4
 - active constant sweep mode parameter, 3-6
 - active constant sweep setting parameter, 3-7
 - baud rate parameter, 3-9
 - cancel, 3-13
 - clock parameter, 3-1 , 3-5
 - configuration mode, 3-2
 - constant sweep mode parameter, 3-1 , 3-7
 - constant sweep setting parameter, 3-1 , 3-7
 - cpu id parameters, 3-10
 - data bits parameter, 3-9
 - default I/O, 3-11
 - dual use checking parameter, 3-1 , 3-8
 - I/O scan parameter, 3-1 , 3-8
 - key click parameter, 3-1 , 3-5
 - modem turnaround time parameter, 3-9
 - parameter listing, 3-1
 - parity parameter, 3-9
 - password (enable / disable), 3-10
 - port idle time parameter, 3-1 , 3-9
 - power-up mode parameter, 3-1 , 3-6
 - program source parameter, 3-1 , 3-6
 - register source parameter, 3-1 , 3-6
 - stop bits parameter, 3-9
- PLC control and status, 8-1
- PLC parameters, Micro, 4-2
- Port idle time parameter, 3-9
- Portability, program / configuration, 2-17
- Power-up
 - disconnect, 2-2
 - EEPROM source, 2-21
 - key sequences, 2-8
 - mode, 2-7
 - operating modes, 2-8
 - options, 2-7
 - sequences, 2-7
- Power-up mode parameter, 3-6
- Program check, 8-14
- Program Edit
 - abort insert / edit, 6-20
 - complete insert / replace, 6-21
 - delete program, 6-11
 - delete step, 6-10
 - description of, 6-1
 - display step / parameter, 6-3
 - enter instruction type, 6-5
 - enter operand, 6-6
 - insert step, 4-6 , 6-5
 - monitor program, 6-17
 - on-line changes, 6-18
 - program syntax errors, 6-20
 - replace step, 6-6
 - search, 6-12
- Program entry, guidelines, 9-6
- Program Mode
 - enter, 6-2
 - exit, 6-21
 - keypad summary, 6-2
- Program organization and user references / data
 - retentiveness of data, 1-5
 - transitions and overrides, 1-4
- Program protection, 8-1
- Program source parameter, 3-6
- Program, entering, 9-5
- Program / configuration portability, 2-17
- Programmable coprocessor module
 - configuration, 5-22
 - editing parameters, 5-22
 - freezing configuration, 5-22
- Programming Examples
 - addition, 9-64
 - AND (logical AND), 9-123
 - array move, bit, 9-292
 - array move, byte, 9-296
 - array move, word, 9-299

- array search, byte, 9-282
 - array search, integer, 9-285
 - BCD to integer conversion, 9-230
 - bit clear, 9-166
 - bit position, 9-173
 - bit set, 9-162
 - bit test, 9-170
 - block clear (BLKCL), 9-199
 - block move (BMOVE), 9-193
 - communications request, 9-221
 - compare value to be within a range of values, 9-116
 - data move, 9-183
 - division, 9-79
 - DOI/O, 9-237
 - down counter (DNCTR), 9-58
 - end master control relay, 9-248
 - equal to comparison, 9-93
 - greater than comparison, 9-101
 - greater than or equal comparison, 9-105
 - integer to BCD conversion, 9-226
 - label, 9-244
 - less than comparison, 9-109
 - less than or equal to comparison, 9-112
 - master control relay, 9-247
 - modulo division, 9-84
 - move bits (MOVBN), 9-189
 - multiple word move (MOVIN), 9-185
 - multiplication, 9-74
 - nested jump, 9-243
 - NOT (logic invert), 9-135
 - not equal comparison, 9-97
 - OR (logical OR), 9-127
 - pid, 9-262
 - pid isa, function 86, 9-254
 - rotate left, 9-151
 - rotate right, 9-157
 - service request, 9-252
 - Shift left, 9-139
 - shift register, bit (SHFRB), 9-209
 - shift register, word (SHFR), 9-203
 - shift right, 9-145
 - square root, 9-88
 - stage bit sequencer (SEQB), 9-215
 - subroutine call, 9-266
 - subtraction, 9-69
 - table functions, 9-268
 - timer, off delay (OFDTR), 9-50
 - timer, on-delay (ONDTR), 9-44
 - timer, stop-watch (TMR), 9-40
 - up counter (UPCTR), 9-54
 - XOR (logical exclusive OR), 9-131
 - PROM option, jumper, 2-11
 - PROM option, user, 2-11
 - Protection Mode, 8-2
 - changing levels, 8-5
 - displaying passwords, 8-7
 - enter, 8-2
 - keypad summary, 8-4
 - modifying passwords, 8-7
 - password enable and disable configuration, 8-3
 - passwords, 8-7
 - subroutine protection levels, 8-12
 - Protection, levels of, 8-1
 - Protection, OEM, 8-1 , 8-2
 - Protection, program, 8-1
- ## R
- Rack parameters, 3-4
 - Rack size, selecting, 5-3
 - Rack, manual configuration, 5-5
 - Rack, remote I/O, 5-5
 - Range, count limits, 4-12
 - Range function
 - double precision, 9-90
 - double precision signed integer, 9-115
 - integer, 9-90
 - signed integer, 9-115
 - word, 9-90 , 9-115
 - Read configuration, 5-17
 - Read function, 2-9
 - Reading a configuration, 5-11 , 5-18
 - Reading a saved configuration, 5-7
 - Reconfiguration, 5-13
 - Reference table function, 7-1
 - Reference table, changing format
 - discrete, 7-5
 - register, 7-6
 - Reference Tables, 7-1
 - change display format, 7-5
 - changing data, 7-7
 - clear data table, 7-9
 - discrete, 7-3 , 7-5
 - list of functions, C-1
 - non-discrete, 7-6
 - register, 7-4
 - registers, special system, 7-11
 - special registers, 7-11 , B-1

- Reference tables, B-1
 - Reference, discrete, overriding, 7-9
 - Reference, top, selecting, 7-7
 - References, special contact, B-1
 - Register reference tables, 7-4
 - Register references
 - analog inputs, 1-3
 - analog outputs, 1-3
 - description of, 1-3
 - system registers, 1-3
 - Register source parameter, 3-6
 - Registers, special system, 7-11
 - Relation Functions, 9-90
 - Relational Functions
 - description of, 9-90
 - double precision equal (func 72), 9-91
 - double precision greater than comparison (func 77), 9-99
 - double precision greater than or equal Comparison (func 75), 9-103
 - double precision less than comparison (func 76), 9-107
 - double precision less than or equal to comparison (func 74), 9-111
 - double precision not equal comparison (func 73), 9-95
 - double precision signed integer range (function 141), 9-115
 - equal (func 52), 9-91
 - greater than comparison (func 57), 9-99
 - greater than or equal comparison (func 55), 9-103
 - less than comparison (func 56), 9-107
 - less than or equal to comparison (func 54), 9-111
 - not equal comparison (func 53), 9-95
 - signed integer range (function 140), 9-115
 - word range (function 142), 9-115
 - Relational functions
 - EQ, DPEQ, 9-90
 - GE, DPGE, 9-90
 - GT, DPGT, 9-90
 - LE, DPLE, 9-90
 - LT, DPLT, 9-90
 - NE, DPNE, 9-90
 - RANGI, RANGDI, RANGW, 9-90
 - Remote I/O rack, configuration of, 5-5
 - Removing OEM protection, 8-11
 - Replacing a configuration, 5-12
- ## S
- Screens, configuration, Micro plc
 - Type A counter, 4-16
 - type B counter, 4-20
 - Search Functions
 - list of, 9-269
 - search equal to, 9-270
 - search greater than, 9-278
 - search greater than or equal to, 9-280
 - search less than, 9-274
 - search less than or equal to, 9-276
 - search not equal to, 9-272
 - Selecting a different top reference, 7-7
 - Selecting rack size, 5-3
 - Selecting slots in a rack, 5-4
 - Series 90 Micro plc, connection to, 2-1
 - Series 90-20, connection to, 2-1
 - Series 90-30 PLC, compatibility with, 4-4, 4-5
 - Series 90-30, connection to, 2-1
 - Service request, programming example, 9-252
 - Shift register bit (SHFRB) function 46, 9-208
 - Shift register SHFR (SHFRW) function 45, 9-201
 - Signed integer, 9-30
 - Slot assignments
 - automatic configuration, 5-7
 - default configuration, 5-14
 - manual configuration, 5-5
 - Micro PLC functions, 4-4
 - remote I/O rack, 5-5
 - Series 90-20, 3-4
 - Series 90-20 plc, 5-3
 - Series 90-30, 3-4
 - Slot selection in rack, 5-4
 - Slot/rack, locating, 5-10
 - Special contact references, B-1
 - Square root, double precision integer, function 71, 9-87
 - Square root, integer, function 70, 9-87
 - Stage bit sequencer (SEQB) function 47, 9-212

Start/stop PLC, 2-9

Statement List Language

- arithmetic functions, 9-61
- basic elements, 9-2
- bit operation functions, 9-121
- control functions, 9-233
- conversion functions, 9-224
- data move functions, 9-183
- editing, 9-35
- editing functions and function blocks, 9-35
- entering a program, 9-5
- function blocks, 9-31
- relational functions, 9-90
- relay ladder logic, 9-1
- standard functions, 9-31
- timers and counters, 9-37

Statement list Language, table functions, 9-268

Status references, system, 1-4

Stop bits parameter, 3-9

Stop-watch timer (TMR) function 10, 9-39

Subroutine

- call function, zoom, 8-13
- declaration mode, 9-7
- edit locked, 8-14
- protection levels, 8-12
- view-locked, 8-12

Subroutine call, function 90, 9-266

Subroutines

- defining, 9-8
- deleting, 9-9
- entering, 9-7
- viewing, 9-8

Substitution groups, on-line, 6-19

System configuration, default, 5-14

System register references, 1-3

System registers, special, 7-11

System status references, 1-4

T

Table Data

- cancel change, 7-8
- change, 7-7
- clear table, 7-9

Table data override, discrete reference, 7-9

Table Functions

- array move, 9-289 , 9-290
- list of, 9-268
- programming examples, array move, 9-292
- programming examples, search functions, 9-282
- search equal to, 9-270
- search greater than, 9-278
- search greater than or equal to, 9-280
- search less than, 9-274
- search less than or equal to, 9-276
- search not equal to, 9-272
- search, array, 9-269

Tables, reference, 7-1

Temporary references, discrete, 1-4

Terms, glossary of, A-1

Timers and Counters

- down counter (DNCTR), 9-57
- off-delay timer (OFDTR), 9-48
- on-delay timer (ONDTR), 9-43
- stop-watch timer (TMR), 9-39
- up counter (UPCTR), 9-53

Top reference, selecting, 7-7

Transferring, Micro PLC program to a Series 90-30 PLC, 4-4

Type A counter specific screens, for Micro plc, 4-16

Type B counter specific screens, for Micro plc, 4-20

U

Up counter (UPCTR) function 15, 9-53

User PROM option, 2-11

User reference, discrete internal, 1-4

User references

- analog inputs, 1-3
- analog outputs, 1-3
- discrete inputs, 1-4
- discrete outputs, 1-4
- discrete references, 1-3
- discrete temporary, 1-4
- global data, 1-4
- system registers, 1-3
- system status, 1-4
- transitions, 1-4

Using the HHP, 1-7

V

Valid on-line changes, 6-19

Verify function, 2-9
Viewing subroutines, 9-8
View-locked subroutine, 8-12

W

Write function, 2-9

The Hand-Held Programmer User's manual for the Series 90™ -30, 90-20, and Micro Programmable Controllers describes how to install and use this compact device to create ladder logic user programs for the Series 90-30, 90-20, and Micro Programmable Logic Controllers (PLC).

Revisions to This Manual

Following is a list of the revisions and corrections to this version of the Hand-Held Programmer for Series 90-30/20/Micro Programmable Controllers User's Manual as compared to the previous version (GFK-0402F).

- Page 3-12, added three paragraphs at bottom of page regarding default I/O configuration.
- Page 3-8, added Note in center of page stating that the dual use checking parameter is not used with the model 351 CPU.
- Pages 5-1 and 5-2, illustrations updated to show Standard power supply.
- Page 5-10, separate heading added, *Assigning Reference Addresses to I/O Modules* to make this discussion a separate area that can easily be referenced for other modules as needed. Also added new second paragraph beginning with, *When the CPU ...*
- Pages 5-15, 5-28, 5-33, 5-38, and 5-43, added paragraph pointing to *Assigning Reference Addresses to I/O Modules* located on page 5-10.
- Page 9-50, corrected description of function in paragraph at top of page, and corrected function block in Ladder Diagram Representation to correctly read .1 seconds.
- Page 9-137, Added paragraph beginning with *If the number of bits to be shifted ...*
- Page 9-143, Added paragraph beginning with *If the number of bits to be shifted ...*

Using This Manual

The information in this manual is arranged as chapters that correspond to the main features or operating modes of the programmer.

Chapter 1. Introduction: This chapter presents an overview of the Hand-Held Programmer.

Chapter 2. Operation: Explains what you will need to know to install and start up the programmer. It also explains the use of the keyboard, operating modes, and Read/Write/Verify functions.

Chapter 3. PLC Configuration: Many PLC parameters are user-configurable. This chapter describes each parameter, its default value, and how it is configured.

Chapter 4. Series 90 Micro PLC Configuration: This chapter describes each parameter for the Micro PLC and describes how it is configured.

Chapter 5. I/O Configuration: Contains information on the configuration of intelligent and non-intelligent I/O modules.

Chapter 6. Program Edit: Describes how to use program mode to create, alter, monitor, and debug Statement List logic programs entered by the user.

Chapter 7. Reference Tables: This chapter describes the Reference Tables function (data mode) which enables you to view and change the contents of data tables within the programmable controller.

Chapter 8. PLC Control and Status: This chapter describes how to use protection mode to control access to various functions of the programmable controller. An additional feature, OEM protection, is also supported. OEM protection supercedes user-specified protection. Information on starting and stopping the PLC is also included in this chapter.

Chapter 9. Statement List Programming Language: This chapter describes the basic elements, functions, and function blocks contained in the Statement List (SL) programming language.

Chapter 10. Error Messages: Summarizes the non-system error messages and/or displays which may occur during the operation of the Hand-Held Programmer.

Appendix A. Glossary: This is a glossary of terms for the Series 90-30 and 90-20 programmable controllers.

Appendix B. Special Contact References: This appendix lists the special contact references which are located in four segments of %S memory, as %S, %SA, %SB, and %SC.

Appendix C. List of Functions: This appendix lists the Series 90-30/20 functions that can be programmed using the Hand-Held Programmer. A description of each function is included.

Appendix D. Function Parameters: This appendix lists the default display formats for each function parameter.

Related Publications:

For more information on Series 90-30, Series 90-20, and Micro PLC products, refer to these publications:

GFK-0255 - Series 90™ PCM and Support Software User's Manual
GFK-0256 - MegaBasic™ Programming Reference Manual
GFK-0293 - Series 90™-30 High Speed Counter User's Manual
GFK-0401 - Workmaster® II PLC Programming Unit Guide to Operation
GFK-0402 - Series 90™-30 and 90-20 PLC Hand-Held Programmer User's Manual
GFK-0412 - Genius™ Communications Module User's Manual
GFK-0466 - Logicmaster 90™ Series 90™-30/20 Micro Programming Software User's Manual
GFK-0467 - Series 90™-30/20 Micro Programmable Controllers Reference Manual
GFK-0487 - Series 90™ PCM Development Software (PCOP) User's Manual
GFK-0499 - CIMPLICITY® 90-ADS Alphanumeric Display System User's Manual
GFK-0582 - Series 90™ PLC Serial Communications Driver User's Manual
GFK-0631 - Series 90™-30 I/O Link Interface User's Manual
GFK-0641 - CIMPLICITY® 90-ADS Alphanumeric Display System Reference Manual
GFK-0664 - Series 90™-30 PLC Axis Positioning Module Programmer's Manual
GFK-0685 - Series 90™ Programmable Controllers Flow Computer User's Manual
GFK-0695 - Series 90™-30 Enhanced Genius™ Communications Module User's Manual
GFK-0726 - Series 90™-30 PLC State Logic Processor User's Guide
GFK-0732 - Series 90™-30 PLC ECLiPS User's Manual
GFK-0750 - OnTOP for Series 90™-30 Online Troubleshooting and Operator Program User's Manual
GFK-0781 - Series 90™-30 Axis Positioning Module Follower Mode User's Manual
GFK-0823 - Series 90™-30 I/O Link Master Module User's Manual
GFK-0828 - Series 90™-30 Diagnostic System User's Manual
GFK-0840 - Series 90™-30 Axis Positioning Module Standard Mode User's Manual
GFK-0898 - Series 90™-30 PLC I/O Module Specifications
GFK-1028 - Series 90™-30 I/O Processor Module User's Manual
GFK-1034 - Series 90™-30 Genius™ Bus Controller User's Manual
GFK-1037 - Series 90™-30 FIP Remote I/O Scanner User's Manual
GFK-1056 - Series 90™-30 State Logic Control System User's Manual
GFK-1065 - Series 90 Micro PLC User's Manual
GFK-1084 - Series 90™-30 TCP/IP Ethernet Communications User's Manual
GFK-1186 - TCP/IP Ethernet Communications for the Series 90-30 PLC Station Manager Manual
GFK-1179 - Series 90™ PLC Installation Requirements for Conformance to Standards

We Welcome Your Comments and Suggestions

At GE Fanuc automation, we strive to produce quality technical documentation. After you have used this manual, please take a few moments to complete and return the Reader's Comment Card located on the next page.

Henry A. Konat
Senior Technical Writer

Contents

Chapter 1	Introduction to the Hand-Held Programmer	1-1
	Keypad	1-1
	LCD Screen	1-2
	PLC Communications	1-2
	Memory Card Interface	1-2
	Operating Modes	1-2
	References	1-3
	Transitions and Overrides	1-4
	Retentiveness of Data	1-5
	Using the Hand-Held Programmer	1-7
Chapter 2	Operation	2-1
	Powering up the Hand-Held Programmer	2-2
	Disconnecting the Hand-Held Programmer	2-2
	Keypad	2-2
	Selecting an Operating Mode	2-8
	Read/Write/Verify Functions	2-9
	Starting/Stopping the PLC	2-9
	Canceling a Mode Change	2-11
	User PROM Option	2-11
	Series 90 Memory Card	2-13
	Program/Configuration Portability	2-17
Chapter 3	Series 90-30/20 PLC Configuration	3-1
	Entering Configuration Mode	3-2
	Keypad Functionality	3-3
	Display Format	3-4
	Locating a Slot or Rack and PLC Parameters	3-4
	Key Click Parameter	3-5
	Clock Parameter	3-5
	Program Source Parameter	3-6
	Register Source Parameter	3-6
	Power-Up Mode Parameter	3-6
	Active Constant Sweep Mode Parameter	3-6
	Active Constant Sweep Setting Parameter	3-7
	Configured Constant Sweep Mode Parameter	3-7
	Configured Constant Sweep Setting Parameter	3-7
	I/O Scan in Stop Mode Parameter	3-8

	Dual Use Checking Parameter	3-8
	Port Idle Time Parameter	3-9
	Baud Rate Parameter	3-9
	Data Bits Parameter	3-9
	Stop Bits Parameter	3-9
	Parity Parameter	3-9
	Modem Turnaround Time Parameter	3-9
	Password(ENABLE/DISABLE)Parameter	3-10
	CPU ID Parameters ID1, ID2, and ID3	3-10
	DefaultI/O	3-11
	Checksum Words Per Sweep	3-13
	Canceling a Configuration Operation	3-13
	Exiting Configuration Mode	3-13
Chapter 4	Series 90 Micro PLC Configuration	4-1
	Section 1: Micro PLC Configuration	4-2
	HHP Configuration Screens	4-3
	Storing the User Program Using the HHP	4-6
	Section 2: High Speed Counter Configuration	4-7
	Parameter Definitions	4-7
	Configuration Screens Common to both Counter Types (ALL A and B1-3, A4)	4-15
	A4 Counter Specific Screens	4-16
	Type B Counter Specific Screens	4-20
Chapter 5	I/O Configuration	5-1
	Selecting Rack Size	5-3
	Selecting Slots in a Rack	5-4
	I/O Slots	5-5
	Remote I/O Rack Configuration	5-5
	Manual Rack Configuration	5-5
	Automatic Rack Configuration	5-7
	Reading a Saved Configuration	5-7
	Keypad Functionality	5-8
	Section 1: Non-Intelligent I/O Modules	5-9
	Assigning Reference Addresses to I/O Modules	5-10
	Locating a Slot or Rack	5-10
	Configuring a Discrete Module	5-10
	Reading a Configuration	5-11
	Deleting an Existing Configuration	5-12
	Replacing a Configuration	5-12
	Canceling a Configuration Operation	5-13
	Reconfiguration	5-13
	I/O Link Interface Module Configuration	5-15

Section 2: Intelligent I/O Modules	5-17
Reading a Configuration	5-17
Section 3: Genius Communications Module	5-18
Reading a Configuration	5-18
Creating a Generic Module Configuration	5-20
Section 4: High Speed Counter	5-21
Section 5: Programmable Coprocessor Module	5-22
Editing PCM Parameters	5-22
Section 6: Analog I/O Modules	5-27
Configuring the 16-Channel Voltage Input Module	5-27
Voltage Ranges and Input Modes	5-27
Module Present	5-28
Selecting %AI Reference	5-29
Removing Module From Configuration	5-29
Selecting Module Mode	5-30
Saved Configurations	5-31
Configuring the 16-Channel Current Input Module	5-32
Current Ranges	5-32
Module Present	5-32
Selecting %AI Reference	5-34
Removing Module From Configuration	5-34
Saved Configurations	5-36
Configuring the 8-Channel Current/Voltage Input Module	5-37
Module Present	5-37
Selecting %I Reference	5-38
Selecting %AQ Reference	5-39
Removing Module From Configuration	5-39
Selecting Module Default Mode	5-40
Saved Configurations	5-41
Configuring the Current/Voltage Combination Input/Output Module ...	5-42
Module Present	5-43
Selecting %AQ Reference	5-43
Selecting %AI Reference	5-44
Selecting %I Reference	5-45
Default Configuration	5-45
Removing Module From Configuration	5-46
Selecting Module Default Mode	5-46
Selecting Input Channel Ranges	5-48
Selecting Low and High Alarm limits	5-48
Freeze Mode	5-49
Saved Configurations	5-50

Chapter 6	Program Edit	6-1
	Entering Program Mode	6-2
	Keypad Functionality	6-2
	Displaying a Step or Parameter	6-3
	Inserting an Instruction Step	6-5
	Replacing an Instruction Step	6-6
	Deleting an Instruction Step	6-10
	Deleting a Program	6-11
	Searching for an Instruction Element	6-12
	Monitoring Program Execution	6-17
	Making On-Line Changes	6-18
	Program Syntax Errors	6-20
	Aborting the Insert/Edit Operation	6-20
	Completing the Insert/Replace Operation	6-21
	Exiting Program Mode	6-21
 Chapter 7	 Reference Tables	 7-1
	Entering Data Mode	7-1
	Keypad Functionality	7-2
	Display Format	7-3
	Changing the Format of a Display	7-5
	Selecting a Different Top Reference	7-7
	Changing Table Data	7-7
	Overriding a Discrete Reference	7-9
	Clearing a Data Table	7-9
	Clearing all Overrides	7-11
	Viewing Special System Registers	7-11
	Exiting Data Mode	7-12
 Chapter 8	 PLC Control and Status	 8-1
	Protection Levels	8-1
	Entering Protection Mode	8-2
	Password Enable and Disable Configuration	8-3
	Keypad Functionality	8-4
	Moving to another level of access	8-5
	Displaying and Modifying Passwords	8-7
	Canceling a Password Change	8-8
	Locking and Releasing OEM Protection	8-8
	Canceling an OEM Protection Operation	8-9
	Displaying and Modifying the OEM Key	8-9
	Removing OEM Protection	8-11
	Canceling an OEM Key Change	8-11
	Reading EEPROM, Memory Card, or Flash Memory With an OEM Key	8-11
	Subroutine Protection Levels	8-12

Chapter 9	Statement List Programming Language	9-1
	Relay Ladder Logic	9-1
	Entering a Program	9-5
	Guidelines for Entering Programs	9-6
	Entering Subroutines	9-7
	How to Enter a Logic Element Using the HHP	9-11
	Data Types	9-30
	Standard Functions and Function Blocks	9-31
	Section 1: Timers and Counters	9-37
	Stop-Watch Timer (TMR) Function 10	9-39
	On Delay (ONDTR) Function 13	9-43
	Off Delay (OFDTR) Function 14	9-48
	Up Counter (UPCTR) Function 15	9-53
	Down Counter (DNCTR) Function 16	9-57
	Section 2: Arithmetic Functions	9-61
	Addition (ADD) Function 60	
	Double Precision Addition (DPADD) Function 61	9-62
	Subtraction (SUB) Function 62	
	Double Precision Subtraction (DPSUB) Function 63	9-67
	Multiplication (MUL) Function 64	
	Double Precision Multiplication (DPMUL) Function 65	9-72
	Division (DIV) Function 66	
	Double Precision Division (DPDIV) Function 67	9-77
	Modulo Division (MOD) Function 68	
	Double Precision Modulo Division (DPMOD) Function 69	9-82
	Square Root, INT (SQRT) Function 70	
	Square Root, DINT (DPSQRT) Function 71	9-87
	Section 3: Relational Functions	9-90
	Equal (EQ) Function 52	
	Double Precision Equal (DPEQ) Function 72	9-91
	Not Equal Comparison (NE) Function 53	
	Double Precision Not Equal Comparison (DPNE) Function 73	9-95
	Greater Than Comparison (GT) Function 57	
	Double Precision Greater Than Comparison (DPGT) Function 77	9-99
	Greater Than or Equal Comparison (GE) Function 55	
	Double Precision Greater Than or Equal Comparison (DPGE) Function 75	9-103
	Less Than Comparison (LT) Function 56	
	Double Precision Less Than Comparison (DPLT) Function 76	9-107
	Less Than or Equal To Comparison (LE) Function 54	
	Double Precision Less Than or Equal To Comparison (DPLE) Function 74	9-111
	Integer Range (RANGI) Function 140	
	Double Precision Range (RANGDI) Function 141	
	Word Range (RANGW) Function 142	9-115

Section 4: Bit Operation Functions	9-121
Bitwise and (AND) Function 23	9-122
Bitwise or (OR) Function 25	9-126
Bitwise Exclusive or (XOR) Function 27	9-130
Bitwise NOT (NOT) Function 29	9-134
Bit Shift Left (SHL) Function 30	9-137
Bit Shift Right (SHR) Function 31	9-143
Bit Rotate Left (ROL) Function 32	9-149
Bit Rotate Right (ROR) Function 33	9-155
Bit Set (BITSET) Function 22	9-161
Bit Clear (BITCLR) Function 24	9-165
Bit Test (BITTST) Function 26	9-169
Bit Position (BITPOS) Function 28	9-172
Masked Compare Word (MSKCOMPW) Function 143	
Masked Compare Dword (MSKCOMPD) Function 144	9-176
Section 5: Data Move Functions	9-183
Multiple Word Move MOVEN (MOVIN and MOVWN) Functions 37 and 42	9-184
Move Bits (MOVBN) Function 40	9-188
Block Move BMOVE (BMOVI and BMOVW) Functions 38 and 43	9-192
Block Clear (BLKCL) Function 44	9-198
Shift Register SHFR (SHFRW) Function 45	9-201
Shift Register Bit (SHFRB) Function 46	9-208
Stage Bit Sequencer (SEQB) Function 47	9-212
Communications Request (COMMREQ) Function 88	9-220
Section 6: Conversion Functions	9-224
Integer to BCD Conversion (BCD) Function 80	9-225
BCD to Integer Conversion (INT) Function 81	9-229
Section 7: Control Functions	9-233
Do I/O Snapshot (DOI/O) Function 85	9-234
Enhanced DOI/O Function for Model 331 and Higher	9-240
Terminate Program Logic Execution (ENDSW) Function 0	9-241
No Operation (NOOP) Function 1	9-241
Nested Jump (JUMP) Function 3	9-242
Nested Master Control Relay (MCR) Function 4	9-246
END MCR Function 8	9-246
LABEL Function 7	9-250
System Service Request (SVCRQ) Function 89	9-251
PID ISA (PIDISA) Function 86	
PID IND (PIDIND) Function 87	9-254
Subroutine Call (CALLSUB) Function 90	9-266

Contents

Section 8: Table Functions	9-268
Array Search Functions	9-269
Search Equal To, Byte (SREQB) Function 101	
Search Equal To, Word (SREQW) Function 102	
Search Equal To, INT (SREQI) Function 103	
Search Equal To, DINT (SREQDI) Function 104	9-270
Search Not Equal To, Byte (SRNEB) Function 105	
Search Not Equal To, Word (SRNEW) Function 106	
Search Not Equal To, INT (SRNEI) Function 107	
Search Not Equal To, DINT (SRNEDI) Function 108	9-272
Search Less Than, Byte (SRLTB) Function 109	
Search Less Than, Word (SRLTW) Function 110	
Search Less Than, INT (SRLTI) Function 111	
Search Less Than, DINT (SRLTDI) Function 112	9-274
Search Less Than or Equal To, Byte (SRLEB) Function 113	
Search Less Than or Equal To, Word (SRLEW) Function 114	
Search Less Than or Equal To, INT (SRLEI) Function 115	
Search Less Than or Equal To, DINT (SRLEDI) Function 116	9-276
Search Greater Than, Byte (SRGTB) Function 117	
Search Greater Than, Word (SRGTW) Function 118	
Search Greater Than, INT (SRGTI) Function 119	
Search Greater Than, DINT (SRGTDI) Function 120	9-278
Search Greater Than or Equal To, Byte (SRGEB) Function 121	
Search Greater Than or Equal To, Word (SRGEW) Function 122	
Search Greater Than or Equal To, INT (SRGEI) Function 123	
Search Greater Than or Equal To, DINT (SRGEDI) Function 124	9-280
Array Move Functions	9-289
Array Move, Bit (MOVABI) Function 130	
Array Move, Byte (MOVABY) Function 131	
Array Move, Word (MOVAW) Function 132	
Array Move, INT (MOVAI) Function 133	
Array Move, DINT (MOVADI) Function 134	9-290
Chapter 10 Error Messages	10-1
Appendix A Glossary	A-1
Glossary of Terms for the Series 90-30/20/Micro PLCs	A-1
Glossary of Basic Instructions and Reference Types for Logicmaster 90-30/20/Micro Software Developed Programs	A-11
Appendix B Special Contact References	B-1
Appendix C List of Functions	C-1
Appendix D Function Parameters	D-1

Figure 1-1. Series 90-30/20/Micro Hand-Held Programmer	1-8
Figure 2-1. Hand-Held Programmer Connection to a Series 90-30 PLC	2-1
Figure 2-2. Hand-Held Programmer Connection to a Series 90-20 PLC	2-1
Figure 2-3. Hand-Held Programmer Cable Connection to a Series 90 Micro PLC	2-1
Figure 2-4. Hand-Held Programmer Keypad	2-3
Figure 2-5. EEPROM Memory Card (Catalog Number IC693ACC303)	2-15
Figure 4-1. Series 90 Micro Programmable Logic Controller	4-1
Figure 5-1. Series 90-30, Model 311 or Model 313 Programmable Logic Controller	5-1
Figure 5-2. Series 90-30, Model 331, Model 340, Model 341, or Model 351 Programmable Logic Controller	5-2
Figure 5-3. Series 90-20 Programmable Logic Controller	5-3
Figure 9-1. Standard ISA PID Algorithm (PIDISA)	9-260
Figure 9-2. Independent Term Algorithm (PIDIND)	9-260

Contents

Table 1-1. Register References	1-3
Table 1-2. Discrete References	1-4
Table 1-3. Range and Size of User References for the Series 90-30 PLC Model 311/313/331/340/344 CPUs	1-5
Table 1-4. Range and Size of User References for the Series 90-30 PLC Model 351 CPU	1-6
Table 1-5. Range and Size of User References for the Series 90-20 PLC	1-6
Table 1-6. Range and Size of User References for the Series 90 Micro PLC	1-7
Table 2-1. Edit and Display Control Keys	2-4
Table 2-2. Ladder Logic Keys	2-5
Table 2-3. Numeric Keys	2-6
Table 2-4. Program Transfer Keys	2-6
Table 2-5. Power-Up Options	2-7
Table 2-6. Special Key Sequences	2-8
Table 2-7. EEPROM and EPROM Memory Catalog Numbers	2-12
Table 2-8. Read/Write/Verify Series 90 Memory Card or EEPROM	2-13
Table 3-1. User-Configurable PLC Parameters	3-1
Table 3-2. Keypad Functionality in PLC Configuration Mode	3-3
Table 3-3. Configuration Screen Format	3-4
Table 4-1. Micro PLC Parameters	4-2
Table 4-2. Common Parameter Abbreviations	4-7
Table 4-3. Abbreviations for All Type A Counter Configuration	4-8
Table 4-4. Abbreviations for Type B1-3/A4 Counter Configuration	4-10
Table 5-1. Keypad Functionality in I/O Configuration Mode	5-8
Table 5-2. Configuration of a Non-Intelligent I/O Module	5-9
Table 5-3. Default I/O Configuration	5-14
Table 5-4. Configuration of an Intelligent I/O Module (Installed)	5-17
Table 5-5. Configuration of an Intelligent I/O Module (Not Installed)	5-17
Table 6-1. Keypad Functionality in Program Mode	6-2
Table 6-2. On-Line Substitution Groups	6-19
Table 7-1. Keypad Functionality in Data Mode	7-2
Table 7-2. Screen Format of a Discrete Reference Table in Binary Format	7-3
Table 7-3. Screen Format of a Discrete Reference Table in Signed Decimal Format	7-3
Table 7-4. Screen Format of a Discrete Reference Table in Hexadecimal Format	7-3
Table 7-5. Screen Format of a Register Table in Binary Format	7-4
Table 7-6. Screen Format for Viewing a %R Table in Timer/Counter Format	7-4
Table 7-7. Screen Format for Displaying Messages in Binary Format	7-5
Table 7-8. Screen Format for Displaying Messages in Signed Decimal and Hexadecimal Format ...	7-5

Table 7-9. Screen Format for Displaying Messages in Timer/CounterFormat	7-5
Table 7-10. Special System Registers	7-11
Table 8-1. Password Protection*	8-1
Table 8-2. OEM Protection	8-2
Table 8-3. Keypad Functionality in Protection Mode	8-4
Table 8-4. Current Access Level	8-5
Table 8-5. Higher Access Level	8-5
Table 8-6. Specify/Change Password for Specified Level	8-7
Table 8-7. Lock and Release OEM Protection	8-8
Table 8-8. Specify/Change OEM Key	8-10
Table 9-1. Statement List Language Basic Elements	9-3
Table 9-2. Allowable Memory Types for Basic Elements	9-6
Table 9-3. Data Types	9-30
Table 9-4. Statement List Language Standard Functions and Function Blocks	9-31
Table 9-5. Operating Registers and Register Locations	9-37
Table 9-6. Operating Registers and Register Locations	9-214
Table 9-7. Service Request Functions	9-251
Table 9-8. PID Function Block Data	9-257
Table 9-9. Array Search Functions	9-269
Table 10-1. Non-System Errors	10-1
Table B-1. Special System Registers	B-2
Table C-1. List of Functions	C-1
Table D-1. Function Parameters	D-1